

CT800ENT TREADMILL

OWNER'S MANUAL

CT800ENT_OwnersManual_800852_20240315

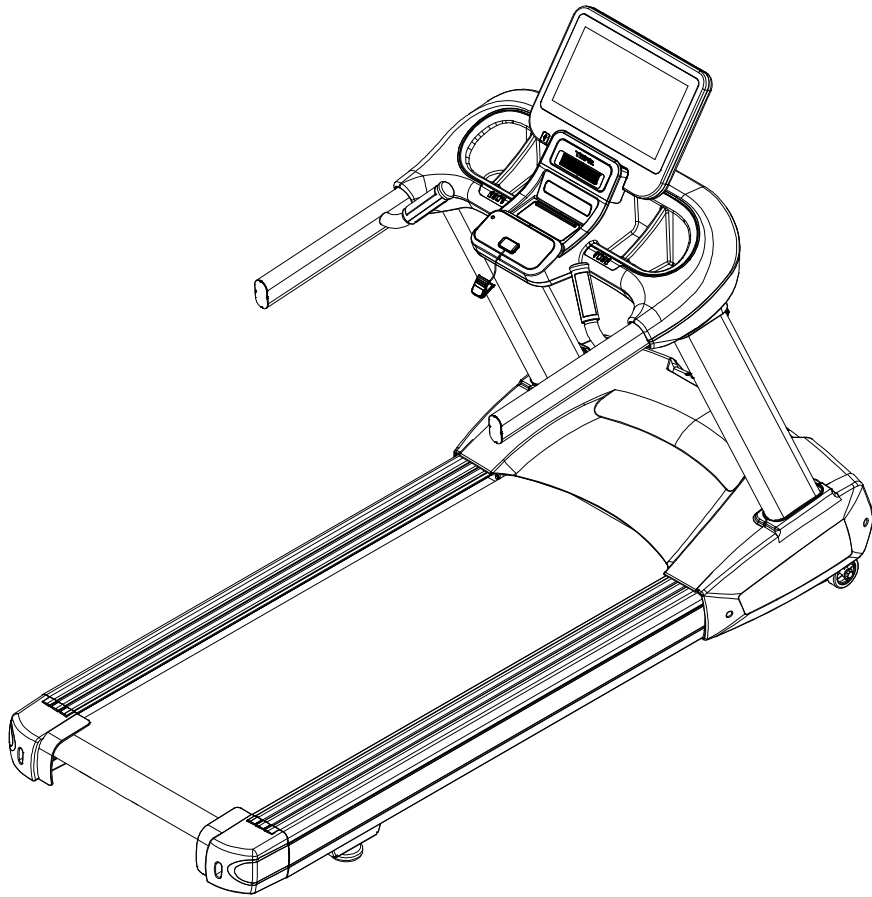

TABLE OF CONTENTS

3	PRODUCT REGISTRATION
4	IMPORTANT SAFETY INSTRUCTIONS
5	IMPORTANT ELECTRICAL INSTRUCTIONS
6	IMPORTANT OPERATION INSTRUCTIONS
8	CT800ENT ASSEMBLY INSTRUCTIONS
14	CONSOLE OPERATION
19	TOUCH SCREEN OPERATION
22	ENTERING PROGRAMS
24	PROGRAM DISPLAY
40	HEART RATE PROGRAMS
47	GENERAL MAINTENANCE
52	TROUBLESHOOTING
53	MANUFACTURER'S LIMITED WARRANTY
58	EXPLODED VIEW
59	PARTS LIST

Thank you for purchasing our product, please save these instructions. Please do not perform or attempt any customizing, adjustments, repair or maintenance that is not described in this manual.



Congratulations on your new Treadmill and welcome to the Spirit Fitness family!

Thank you for your purchase of this quality Treadmill from Spirit Fitness. Your new Treadmill was manufactured by one of the leading fitness manufacturers in the world and is backed by one of the most comprehensive warranties available. Through your dealer, Spirit Fitness will do all we can to make your ownership experience as pleasant as possible for many years to come. If not purchased direct from Spirit Fitness, the local dealership where you purchased this Treadmill is your administrator for all Spirit Fitness warranty and service needs. Their responsibility is to provide you with the technical knowledge and service personnel to make your experience more informed and any difficulties easier to remedy.

Please take a moment at this time to record the name of the dealer, their telephone number, and the date of purchase below to make any future, needed contact easy. We appreciate your support and we will always remember that you are the reason that we are in business.

Yours in Health,
Spirit Fitness

NAME OF DEALER _____

DEALER PHONE # _____

PURCHASE DATE _____

RECORD YOUR SERIAL NUMBER

Please record the serial number of this fitness product in the space provided below.

Serial Number:

Serial Number Location

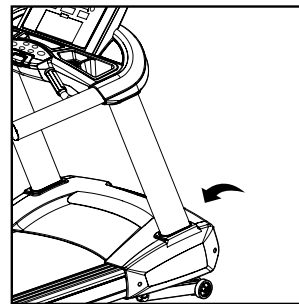

REGISTER YOUR PURCHASE

The self-addressed product registration card must be completed in full and returned to Spirit Fitness. You can also go to <http://www.spiritfitness.com/warranty> under the Support tab to register online.

IMPORTANT SAFETY INSTRUCTIONS

WARNING

Read all instructions before using this appliance.

DANGER - To reduce the risk of electric shock disconnect your SPIRIT treadmill from the electrical outlet prior to cleaning and/or service work.

WARNING - To reduce the risk of burns, fire, electric shock, or injury to persons, install the treadmill on a flat level surface with access to a 120-volt AC, 15-Amp. grounded outlet. With only the treadmill plugged into the circuit.

DO NOT USE AN EXTENSION CORD UNLESS IT IS 14 AWG OR LARGER, WITH ONLY ONE OUTLET ON THE END. The treadmill should be the only appliance in the electrical circuit.

DO NOT ATTEMPT TO DISABLE THE GROUNDED PLUG BY USING IMPROPER ADAPTERS, OR IN ANY WAY MODIFY THE CORD SET. A serious shock or fire hazard may result along with computer malfunctions.

- Do not operate treadmill on deeply padded, plush or shag carpet. Damage to both carpet and treadmill may result.
- Do not block the rear of the treadmill. Provide a minimum of 1 meter clearance between the rear of the treadmill and any fixed object.

- Keep children away from the treadmill. There are obvious pinch points and other caution areas that can cause harm.
- Keep hands away from all moving parts.
- Never operate the treadmill if it has a damaged cord or plug. If the treadmill is not working properly, call your dealer.
- Keep the mains cord away from heated surfaces.
- Do not operate where aerosol spray products are being used or where oxygen is being administered. Sparks from the motor may ignite a highly gaseous environment.
- Never drop or insert any object into any openings.
- Do not use outdoors.
- To disconnect, turn all controls to the off position, remove tether cord, then remove the plug from the outlet.
- Do not attempt to use your treadmill for any purpose other than for the purpose it is intended.
- The pulse sensors are not medical devices. Various factors, including the user's movement, may affect the accuracy of heart rate readings. The pulse sensors are intended only as exercise aids in determining heart rate trends in general.
- Use handrails provided; they are for your safety.
- Wear proper shoes. High heels, dress shoes, sandals or bare feet are not suitable for use on your treadmill. Quality athletic shoes are recommended to avoid leg fatigue.
- This appliance is not intended for use by persons (including children) with reduced physical, sensory or mental capabilities,

or lack of experience and knowledge, unless they have been given supervision or instruction concerning use of the appliance by a person responsible for their safety.

- Do not modify the plug provided with the product if it will not fit the outlet; have a proper outlet installed by a qualified electrician.
- Remove tether cord after use to prevent unauthorized treadmill operation.
- **Recommended User Weight Limit: 450 lb**

SAVE THESE INSTRUCTIONS - THINK SAFETY!

IMPORTANT ELECTRICAL INSTRUCTIONS

⚠️ WARNING

NEVER use a RCD - Residual Current Device (U.S. ver.= GFCI) - wall outlet with this treadmill. As with any appliance with a large motor, the RCD/GFCI will trip often. Route the main power cord away from any moving part of the treadmill including the elevation mechanism and transport wheels.

NEVER remove any cover without first disconnecting AC power. If voltage varies by ten percent (10%) or more, the performance of your treadmill may be affected. Such conditions are not covered

under your warranty. If you suspect the voltage is low, contact your local power company or a licensed electrician for proper testing.

NEVER expose this treadmill to rain or moisture. This product is NOT designed for use outdoors, near a pool or spa, or in any other high humidity environment. The operating temperature specification is 40 to 120 degrees Fahrenheit, and humidity is 95% non-condensing (no water drops forming on surfaces).

Circuit Breakers: Some circuit breakers used in homes are not rated for high inrush currents that can occur when a treadmill is first turned on or even during use. If your treadmill is tripping the house circuit breaker (even though it is the proper current rating) but the circuit breaker on the treadmill itself does not trip, you will need to replace the home breaker with a high inrush type. This is not a warranty defect. This is a condition we as a manufacturer have no ability to control. This part is available through most electrical supply stores.

GROUNDING INSTRUCTIONS

This product must be grounded. If the treadmill should malfunction or breakdown, grounding provides a path of least resistance for electric current, reducing the risk of electric shock. This product is equipped with a cord having an equipment-grounding plug. The plug must be plugged into an appropriate outlet that is properly installed and grounded in accordance with all local codes and ordinances.

DANGER - Improper connection of the equipment-grounding conductor can result in a risk of electric shock. Check with a qualified electrician or serviceman if you are in doubt as to whether the product is properly grounded. Do not modify the plug provided with the product if it will not fit the outlet; have a proper outlet installed by a qualified electrician.

This product is for use on a nominal 120-volt/15 amp dedicated circuit, and has a grounding plug that looks like the plug illustrated below. A temporary adapter that looks like the adapter illustrated below may be used to connect this plug to a 2-pole receptacle as shown below if a properly

grounded outlet is not available. The temporary adapter should be used only until a properly grounded outlet, (shown below) can be installed by a qualified electrician. The green colored rigid ear-lug, or the like, extending from the adapter, must be connected to a permanent ground such as a properly grounded outlet box cover. Whenever the adapter is used, it must be held in place by a metal screw.

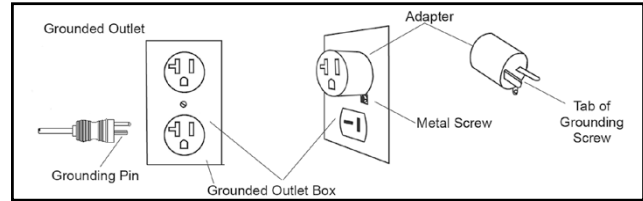

IMPORTANT OPERATION INSTRUCTIONS

- NEVER operate this Treadmill without reading and completely understanding the results of any operational change you request from the computer.
- Understand that changes in speed or incline do not occur immediately. Set your desired speed or incline level on the computer console and release the

adjustment button. The computer will obey the command gradually.

- Use caution while participating in other activities while on your Treadmill; such as watching television, reading, etc. These distractions may cause you to lose balance which may result in serious injury.
- Do not use excessive pressure on console control buttons. They are precision set to function properly with little finger pressure.

WARNING

This product can expose you to chemicals including Toluene and Acrylamide which are known to the State of California to cause Cancer and birth defects or other reproductive harm. For more information, go to www.P65Warnings.ca.gov

CT800ENT PRE-ASSEMBLY

UNPACKING

1. Cut the straps, then along the dotted line on the bottom of the box; lift the box over the unit and unpack.
2. Locate the hardware package. The hardware is separated into four steps. Remove the tools first. Remove the hardware for each step as needed to avoid confusion. The numbers in the instructions that are in parenthesis (#) are the item number from the assembly drawing for reference.

TOOLS INCLUDED:

- 3/8" Allen Wrench
- 10mm Allen Wrench
- Phillips Screwdriver

PARTS INCLUDED:

- 2 Console Masts
- 2 Side Covers
- 1 Base Frame
- 1 Console Support
- 1 Console
- 1 Safety Button
- 1 Power Cord
- 1 Hardware Kit

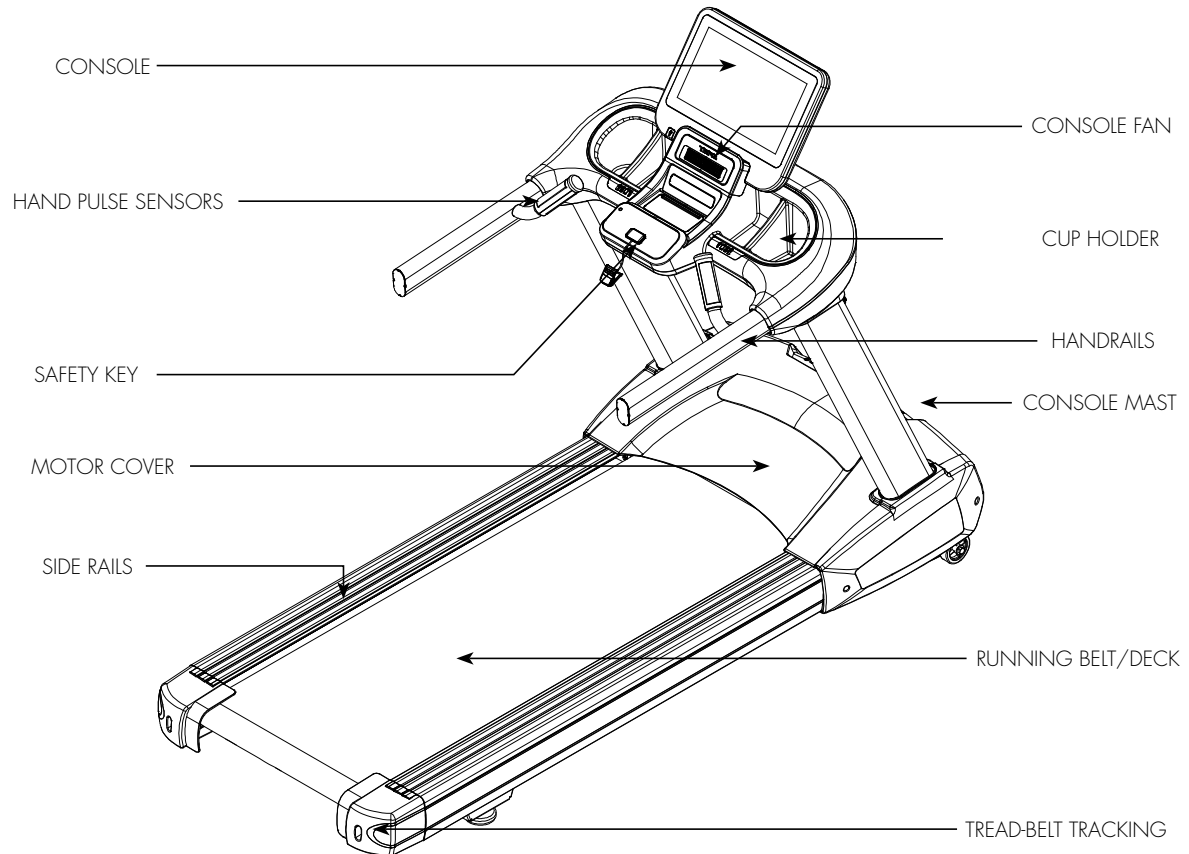

CT800ENT STEP ONE

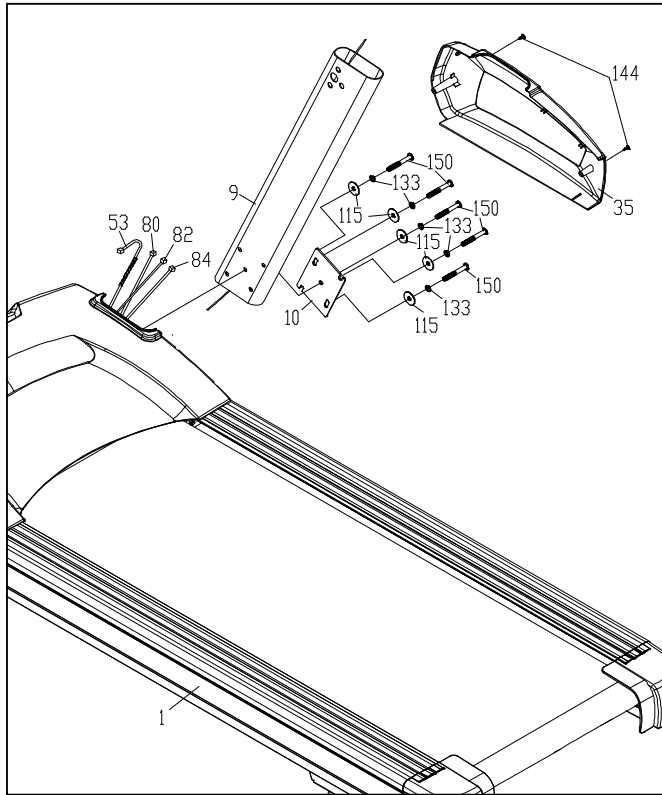

HARDWARE FOR STEP 1

PART	TYPE	DESCRIPTION	QTY
115	Flat Washer	Ø3/8" × 35 × 2.0T	10
133	Split Washer	Ø10 × 2T	10
144	Phillips Head Screw	M5 × 12m/m	4
150	Button Head Socket Bolt	3/8" × 3"	10

1. Thread the all **Cables (No.53/80/82/84)** up through the center of the **Right Upright Column (No.9)**.
2. Use five sets of **Button Head Socket Bolt (No.150)**, **Split Washer (No.133)** against a **Flat Washer (No.115)** to secure the **Upright Fixing Plate (No.10)** to the **Right Uprights (No.9)** to the **Main Frame (No.1)** using the **Allen Wrench (No.160)**.
3. Use two **Phillips Head Screws (No.144)** to secure the **Motor Base Cap Right (No.35)** to **Main Frame (No.1)** using the **Screw Driver (No.158)**.
4. Repeat the previous two steps on the left side.

CT800ENT STEP TWO

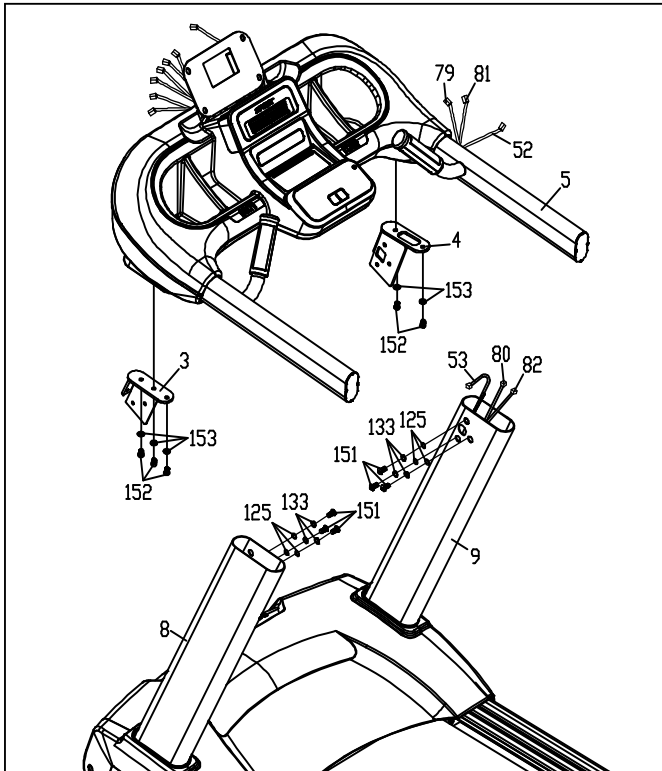

HARDWARE FOR STEP 2

PART	TYPE	DESCRIPTION	QTY
125	Flat Washer	Ø3/8" × Ø25 × 2.0T	6
133	Split Washer	Ø10 × 2T	6
151	Button Head Socket Bolt	3/8" × 3/4"	6
152	Socket Head Cap Bolt	M8 × 12m/m	5
153	Flat Washer	Ø8 × Ø16 × 2T	5

- On the underside of the **Console Support (No.5)** is where the **Locking Plate Assembly (No. 3 & 4)** can be attached. Use 2 **Socket Head Cap Bolts (No.152)** and 2 **Flat Washers (No.153)** on each side to secure.
- Connect all cables with the correct pairing:
 - The **Computer Cable (No. 53)** with the **Upper Computer Cable (No.52)**.
 - The **Ethernet Cable (No. 80)** with the **Upper Ethernet Cable (No.79)**.
 - The **C-safe Cable (No. 82)** with the **Upper C-safe Cable (No.81)**.
Note: Be careful not to pinch the wires and slide them into the **Right Upright (No.9)**.
- Gently slot the **Console Support (No.5)** into the **Left/ Right Uprights (No.8 & 9)** and secure with 3 **Button Head Socket Bolts (No.151)**, 3 **Split Washers (No.133)**, and 3 **Flat Washers (No.125)** on both sides using the **Allen Wrench (No.160)**.

CT800ENT STEP THREE

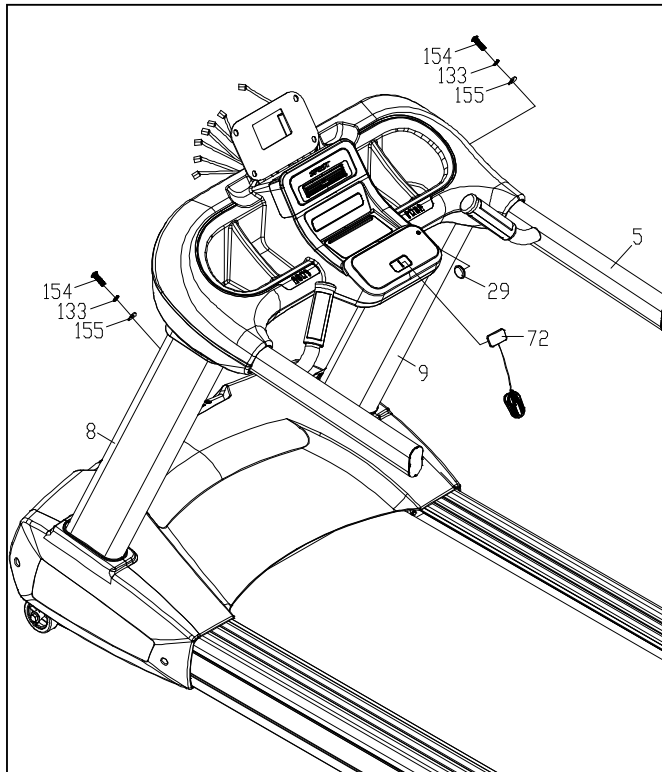

HARDWARE FOR STEP 3

PART	TYPE	DESCRIPTION	QTY
133	Split Washer	Ø10 × 2T	2
154	Button Head Socket Bolt	3/8" × UNC16 × 1-1/4"	2
155	Curved Washer	Ø10 × Ø23 × 1.5T	2
29	Round Cap		1

1. Further secure the uprights by inserting a **Button Head Socket Bolt (No.154)** through a **Split Washer (No.133)**, and a **Curved Washer (No.155)** onto the backside of both **Left/Right Uprights (No. 8 & 9)** using the **Allen Wrench (No.160)**.
2. Plug the **Round Cap (No.29)** into the **Right Upright (No.9)**.
3. Plug the **Safety Key (No.72)** into the Safety Key base on the **Console Support (No.5)**.

CT800ENT STEP FOUR

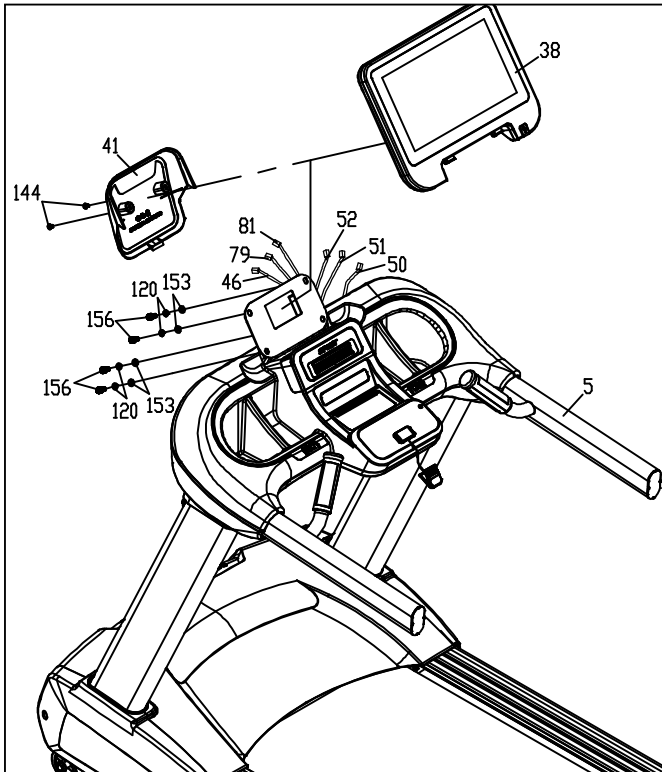

HARDWARE FOR STEP 4

PART	TYPE	DESCRIPTION	QTY
120	Split Washer	5/16" × 1.5T	4
144	Phillips Head Screw	M5 × 12m/m	2
153	Flash Washer	Ø8 × Ø16 × 2T	4
156	Socket Head Cap Bolt	M8 × P1.25 × 20L	4

1. Place the **Console Assembly (No.38)** onto the **Console Support (No.5)**. Secure with 4 **Socket Head Cap Bolts (No.156)**, 4 **Split Washers (No.120)**, and 4 **Flat Washers (No.153)** using the **Allen Wrench (No.159)**.
2. Connect all cables to **Console Assembly (No.38)**:
 - a. The **Upper Handpulse Wires (No.50 & 51)**.
 - b. The **Upper Computer Cable (No.52)**.
 - c. The **Grounding wire (No.46)**.
 - d. The **Upper Ethernet Cable (No.79)**.
 - e. The **Upper C-safe Cable (No.81)**.
3. Fasten the **Console Cover (No.41)** with 2 **Phillips Head Screws (No.144)** to the **Console Support (No.5)** using the **Screw Driver (No.158)**.



CT800ENT CONSOLE OPERATION



STARTING OPERATION

- Plug in the power cord and switch on the main power switch located at the front of the treadmill. Make sure the safety key is inserted (machine will not operate without the presence of the safety key.)
- When the power is turned **ON**, the screen will show a brief loading screen and then display the **Home Screen** which indicates that the machine is ready to operate.

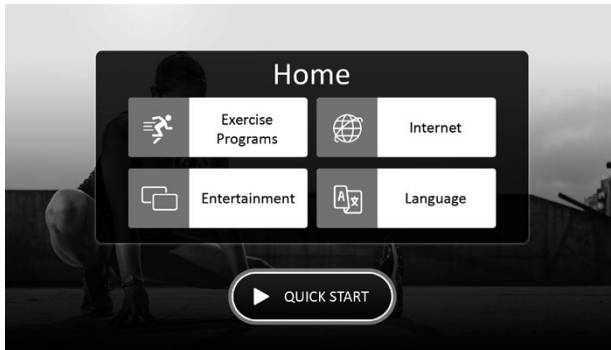

Home Screen: Begin operation by touching the icons.



Quick operating buttons are conveniently located for basic treadmill functions.

FUNCTIONS OF THIS TREADMILL

The touchscreen is used for operating most functions of the treadmill. You can directly touch any button on the screen, or use the **Quick Operating Buttons** to control the treadmill's various functions. The **Speed ▲/▼** buttons control the speed, the **Start** button begins the workout, the **Stop** button will pause or stop the workout, and **Incline ▲/▼** buttons control the degree of incline of the treadmill.

QUICK START

Press the **Start** button to begin belt movement at 0.5 mph then adjust to the desired speed using the **Speed ▲/▼** button.

- To slow the treadmill belt, press the **Speed ▼** key until the desired speed is reached.
- To stop the treadbelt press and release **Stop** button.

PAUSE/STOP

When the treadmill is running, the **PAUSE** feature may be utilized by pressing the red **Stop** button once. This will slowly decelerate the treadbelt to a stop. The incline will go to zero percent. The **Time**, **Distance** and **Calorie** readings will hold while the unit is in the pause mode. After 5 minutes the display will reset and return to the start-up screen.

- To resume your exercise when in **PAUSE** mode, press the **Start** button.
- Pressing the **Stop** button twice will end the program and a workout summary will be displayed. If the **Stop** button is pressed a third time, the console will return to the idle mode (start-up screen).

INCLINE

Incline may be adjusted any time after the belt starts moving.

- Press and hold the adjustment **Incline ▲ / ▼** buttons to achieve desired level of incline.

HEART RATE FEATURE

The **Pulse (Heart Rate)** on the screen shows the current value of the heart beats per minute. You must use both left and right stainless steel sensors to pick up your pulse. Pulse values are displayed anytime the computer is receiving a signal from the hand pulse sensors. You may use the hand pulse sensors while in Heart Rate Control. The CT800ENT will also pick up wireless heart rate transmitters that are Polar and Bluetooth compatible.

TOUCHSCREEN OPERATION LANGUAGE

There are 13 languages to choose from. Select your desired language by tapping it on the screen. Once selected, the system will return to the **Home Screen** with your new language being used. To return to the **Home Screen** without selecting a new language, press the **Home** button in the upper left corner of the screen.

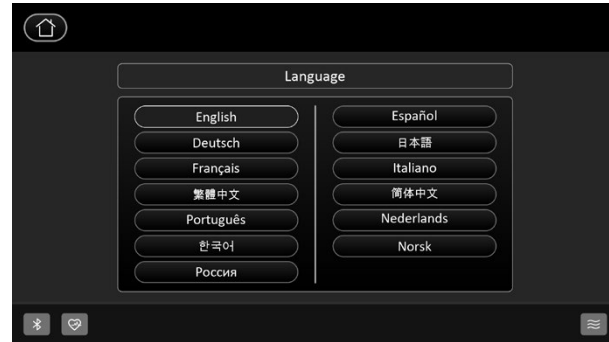

INTERNET

The **Internet** section offers various streaming, news, and social media options. The machine must be connected to the internet in order for the apps to work. Simply click on the app of your choice to connect. Follow any on-screen prompts to continue login or other authorizations as needed.

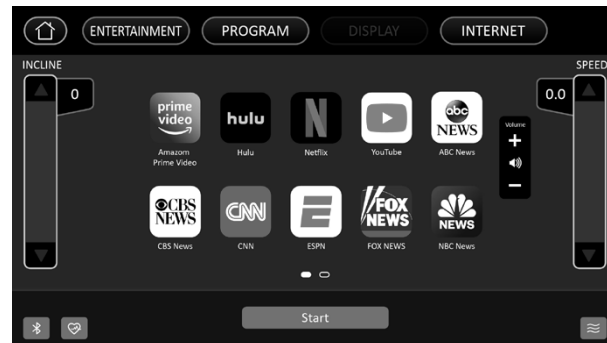

SCREEN MIRRORING

When **Screen Mirroring** is selected from the **Entertainment** screen, you may begin pairing your device.

iOS

Screen Mirroring displays your phone's screen on the touchscreen of the treadmill. Please note that your device must be running iOS 8 or higher.

1. Connect your phone or tablet to the facility's WiFi.
2. Find and select the **Screen Mirroring** button on your phone or tablet by swiping up from your phone's main screen or by swiping down from the top left corner of the screen if you have a newer iOS installed.

Note: When using an iOS device for **Screen Mirroring**, your Bluetooth headphones must be connected to the console.

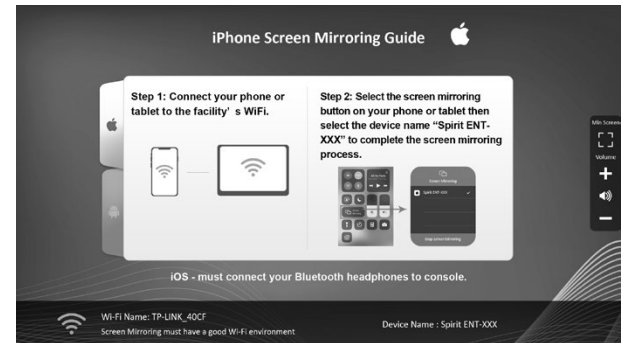
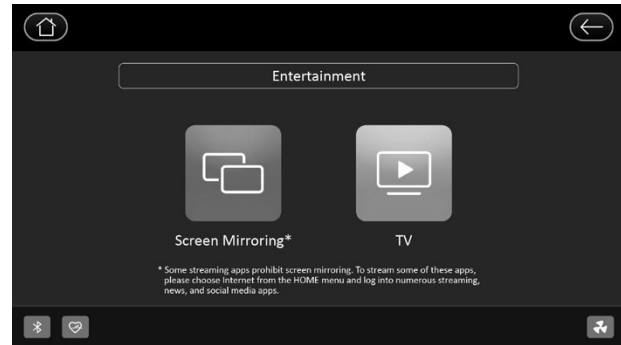

SCREEN MIRRORING

Android

Screen Mirroring displays your phone's screen on the touchscreen of the treadmill.

1. Connect your phone or tablet to the facility's WiFi.
2. Scan the QR code or search for "Spirit Mirroring" in the Google Play store on your phone or tablet.
3. Download the app.
4. Open the Spirit Mirroring App and select the device name. Then, click **Start Mirroring** to complete the screen mirroring process.
Note: When using an Android device for Screen Mirroring, your Bluetooth headphones must be connected to the your device.



ENTERING A PROGRAM & CHANGING SETTINGS

When the **Exercise Programs** button is selected from the **Home Screen**, the screen displays a menu of the different programs available: **Manual, Hill, Fat Burn, Cardio, Interval, Heart Rate 1, Heart Rate 2, Custom, 5k Run, 10k Run, HIIT, and Fitness Test**. To select and start a preset program:

1. Select a program by tapping it on the screen, then press **Enter** to begin. Customize the program on the following screens by entering your data, or press the **Start** button to begin the program using the default settings.
3. Press the **Start** button to begin your workout, or press the **Stop** button to return to the previous screen.
4. Once the workout begins, a 3- minute warm-up will commence. You can press the **Start** button to bypass this and go straight to the workout. During the warm-up the clock will count down from three minutes. Note: 5K Run, 10K Run, HR, Custom, Fitness Tests and the manual programs do not have a warm-up.

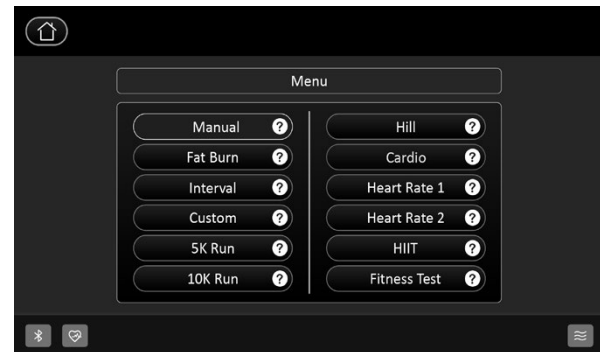
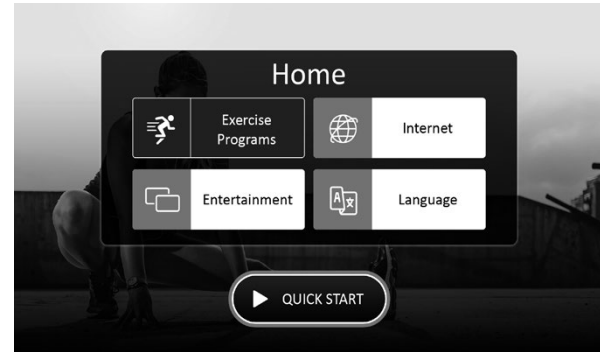

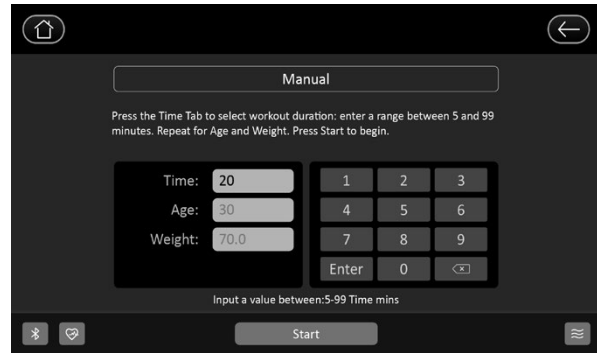

EXERCISE PROGRAM

CHANGING THE WORKOUT DISPLAY

During your workout, you may change the display based on the view that works best for your needs. Once your workout begins, you will see 3 preset views available at the bottom of the screen: **Simple**, **Track**, and **Dashboard**.

SIMPLE

To switch the display to **Simple** view, simply tap the **Simple** button at the bottom of the screen. This view shows a muscle activation profile for the current workout, an overview of the Incline and Speed profile, as well as the elapsed **Distance**, **Calories/Hr**, **Total Time**, **Age**, and **METs** as well as other exercise data.

TRACK

To switch the display to **Track** view, simply tap the **Track** button at the bottom of the screen. This view shows a virtual track that corresponds with the current workout, as well as the elapsed **Distance**, number of **Laps**, **Calories**, **Total Time**, **Heart Rate**, and **Pace** as well as other exercise data.

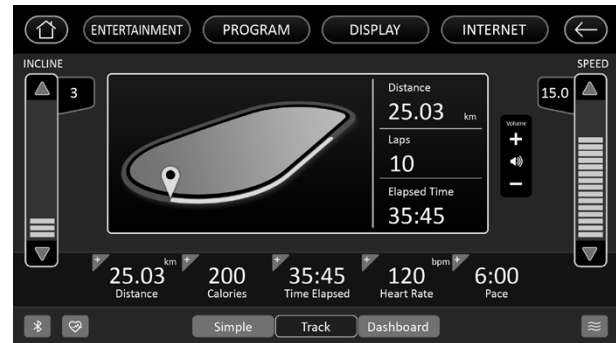
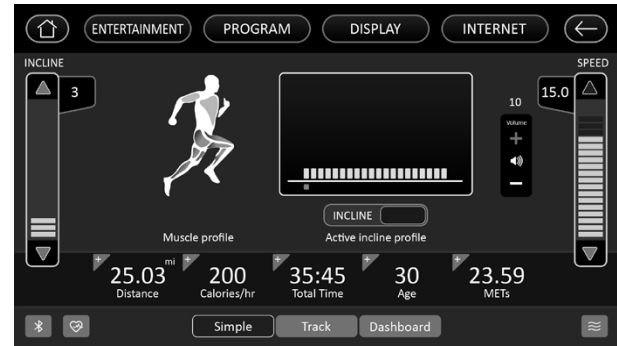

EXERCISE PROGRAM

DASHBOARD

To switch the display to **Dashboard** view, simply tap the **Dashboard** button at the bottom of the screen. This view shows a virtual dashboard mimics a typical treadmill display with information that corresponds with the current workout. Metrics such as elapsed **Distance**, **Calories/Hr**, **Calories**, **Total Time**, **Heart Rate**, and **Pace** are displayed as well as other exercise data.

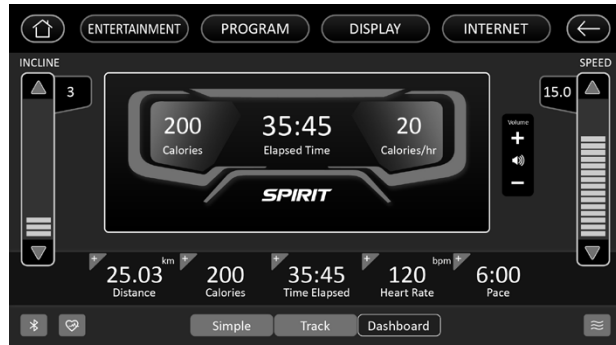

PRESET PROGRAMS SPEED/INCLINE SETTINGS

The preset program **Speed** and **Incline levels** are shown in the chart below. The **Speed** numbers shown in the chart indicate a percentage of the top speed of the program. For instance, the first **Speed** setting for HILL (Program 1, HILL) shows the number 20. This means that this segment of the program will have a speed that is 20% of the top speed for the program (The user sets the top speed in the procedure above). If the user sets the top speed to 10 mph, then the first segment will be 2 mph. You will notice that segment 12 shows 100 which means the speed will be set to 100% of 10 mph or simply 10 mph.

Prog	SEG	Warm up																				Cool down					
		1	2	3	4	5	6	7	8	9	10	11	12	13	14	15	16	17	18	19	20						
Hill	Speed	20	30	40	50	62.5	62.5	70	70	75	75	87.5	87.5	100	100	87.5	87.5	75	75	70	70	62.5	62.5	80	40	30	20
	Incline	0	0	0	0	1	2	3	3	4	3	4	4	5	3	4	3	4	5	4	3	1	1	0	0	0	0
Fatburn	Speed	20	30	40	50	62.5	75	100	100	100	100	100	100	100	100	100	100	100	100	100	100	100	75	50	40	30	20
	Incline	0	0	0	0	1	2	3	3	4	5	3	4	4	3	2	3	4	5	6	4	2	1	0	0	0	0
Cardio	Speed	20	30	40	50	60	60	70	70	70	80	70	70	80	80	60	70	80	80	70	70	70	100	70	40	30	20
	Incline	0	0	0	0	1	1	2	2	3	2	2	3	1	2	3	2	2	4	2	3	1	1	0	0	0	0
Interval	Speed	20	30	40	50	62.5	62.5	100	100	62.5	62.5	100	100	62.5	62.5	100	100	62.5	62.5	100	10	62.5	62.5	50	40	30	20
	Incline	0	0	0	0	1	2	3	5	2	3	6	2	3	7	2	3	8	2	3	5	3	1	0	0	0	0

MANUAL

Both **Speed** and **Incline** are controlled by the user. Increase or decrease levels at any time during your workout.

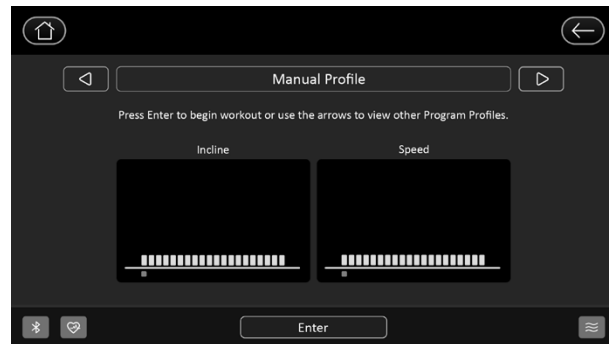
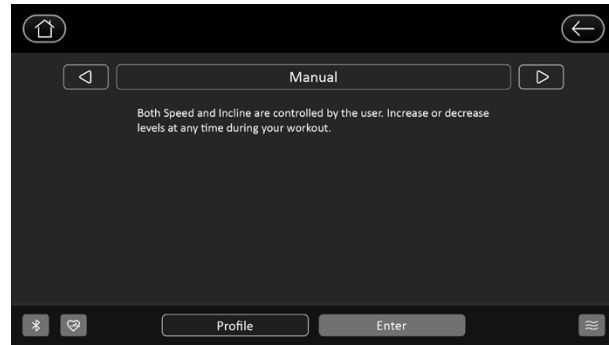

HILL

Speed: This program follows a triangle or pyramid type of gradual progression from approximately 10% of maximum effort (the level that you choose before starting this program) up to a maximum effort which lasts for 10% of the total workout time, then a gradual regression of Speed back to approximately 10% of maximum effort

Incline: The deck elevation is a more gradual and sustained progression. Maximum elevation is in the middle of the workout and lasts for 10% of the duration.

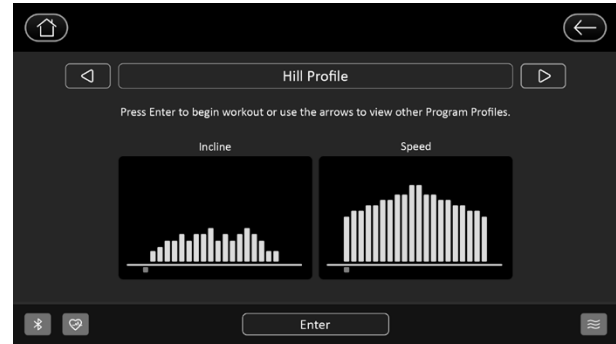

FAT BURN

Speed: This program follows a quick progression up to the maximum speed level (default or user input level) that is sustained for 2/3 of the workout. This program will challenge your ability to sustain your energy output for an extended period of time.

Incline: The deck elevation is a quick and sustained progression up to the maximum value (default or user input) for 90% of the workout duration.



CARDIO

Speed: This program presents a quick progression up to near maximum speed level (default or user input level). It has slight fluctuations up and down to allow heart rate to elevate, and then recover repeatedly, before beginning a quick cool down. This will build up your heart muscle and increase blood flow and lung capacity.

Incline: The elevation in this program is moderate. There are several elevation spikes at different points of the workout. Segments 4, 9, and 14 are maximum elevation for this program.

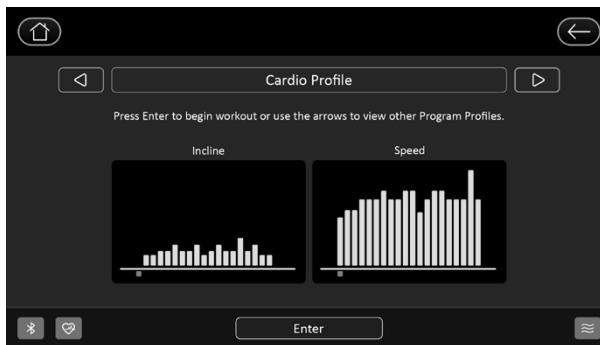

5K RUN / IOK RUN

Both speed and incline are controlled by the user. Increase or decrease levels at any time during your workout. When the program begins, the distance will begin to count down; once it reaches zero the program ends.

*Please note that the **Speed** readout is in MPH if the console is not set to display Metric measurements.

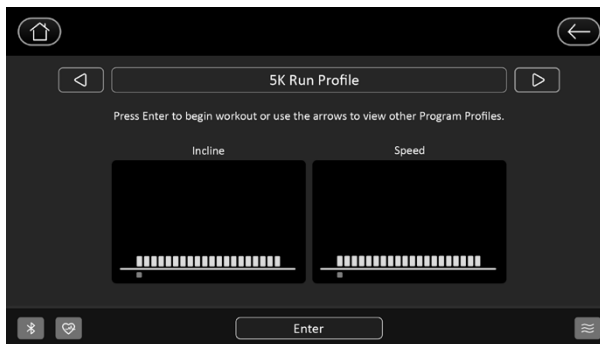

INTERVAL

Speed: This program takes you through high levels of intensity followed by recovery periods of low intensity. This program utilizes and develops your "Fast Twitch" muscle fibers which are used when performing tasks that are intense and short in duration. These deplete your oxygen level and spike your heart rate, followed by periods of recovery and heart rate drop to replenish oxygen.

Incline: All of your lower extremity muscles will be equally challenged throughout this program. The incline alternates between 25% and 65% of maximum elevation.

HR 1 / HR 2

The default value is 65% or 80% of your projected rate maximum. You have the option of changing your target heart rate. The machine will attempt to keep you within five beats of your target heart rate. (See more HR information on page 43-46)

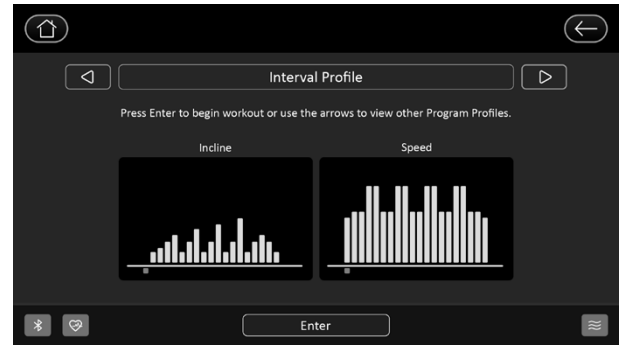

CUSTOM

You will create the desired speed and incline levels for each of the 20 segments of the program using the keyboard on the screen. You may change these levels at any time during the workout.

TO BEGIN A CUSTOM PROGRAM:

1. Select the **Custom** program then press the **Enter** key to begin customizing the program with your personal data, or just press the **Start** key to begin the program with the default settings.
2. To adjust the **Speed** and **Incline** profiles, use the on-screen interface to achieve desired workout profiles. Once complete, press **Next** to save and continue.
3. The following screens will ask you to enter the desired **Time**, the user **Age**, and **Weight**. You may use the default values, or adjust as needed. Press **Start** once complete to begin your new custom workout program!

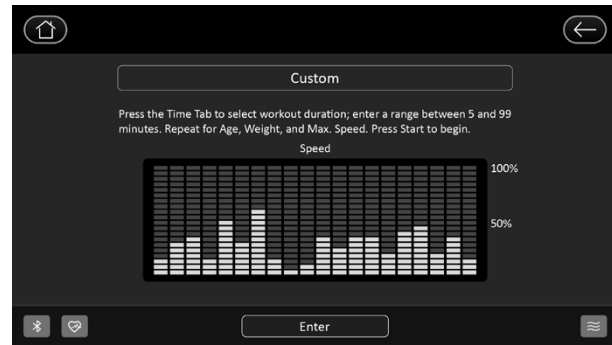

HIIT PROGRAM

The **HIIT**, or **High Intensity Interval Training**, program takes advantage of the latest trend in fitness. During the program you will perform short bursts of high intensity sprinting followed by short rest periods. HIIT is a fully customizable interval training program. You can enter the number of intervals, time of each interval Sprint and Rest periods and the work intensity of the levels.



1. Select a program then press the **Enter** key to begin customizing the program with your personal data, and you are asked for and the number of intervals you want to do. The default is 8 and the range available is 3 to 15. One interval equals 1 Sprint and 1 Rest segment.
2. Next is entering the **Interval** time, **Sprint** time and **Rest** time. You may to select the **Sprint** time or **Rest** time from 20 to 90 seconds. After the interval time is set, set the intensity training to **Sprint** speed and **Rest** Speed. This is the resistance level you will experience during HIIT program workout.
3. You may now press **Start** to begin the HIIT program after to adjust the speed. The program starts with a 3-minute warm-up period with the speed set to 50% of the sprint speed selected previously. You can manually adjust the speed during warm-up if you wish.

FITNESS TEST

When the **Fitness Test** button is selected from the **Exercise Programs Menu** screen, the screen displays the different preset tests available: **Coast Guard, Navy, Air Force, Army, Gerkin, Marine Corps, and Physical Efficiency Battery (PEB)**. Tap the test you would like to begin.

Before the Test:

- Make sure you are in good health; check with your physician before performing any exercise if you are over the age of 35 or persons with pre-existing health conditions.
- Make sure you have warmed up and stretched before taking the test.
- Do not take in caffeine before the test.
- If using the hand pulse sensors hold the hand grips gently, do not tense up.

Starting the Test:

1. At the beginning of each program you will be prompted to enter your **Age, Weight, Height, and Gender**. Adjust the settings as necessary and press the **Enter** button to accept and continue.

2. Once data is entered, press **Start** to begin the test.

During the GERKIN Test:

- The console must be receiving a steady heart rate for the test to begin. You may use the hand pulse sensors or wear a heart rate chest strap transmitter (sold separately).
- The test will start with a 3-minute warm-up at 3 MPH before the actual test begins (GERKIN only).

After the GERKIN Test:

- Cool down for about one to three minutes.
- Take note of your score because the console will automatically return to the start-up mode after a few minutes.

AIR FORCE

A timed 1.5 mile run. You control the speed manually. Maximum time allowed to pass the test is shown on the table:

For more detailed information, visit:
<http://bit.ly/SF-AirForce>

AGE	MALE	FEMALE
<30	13:36	15:50
30-39	14:00	16:57
40-49	14:52	18:14
50-59	16:22	19:43
60+	18:14	22:28

ARMY

A timed 2 mile run. You control the speed manually. Maximum time allowed to pass the test is shown on the table.

For more detailed information, visit:
<http://bit.ly/SF-Army>

AGE	MALE	FEMALE
≤21	20:12	23:48
22-26	21:54	25:30
27-31	22:30	26:30
32-36	24:12	26:30
37+	25:12	26:30

NAVY

A timed 1.5 mile run. You control the speed manually. Maximum time allowed to pass the test is shown on the table:

For more detailed information, visit: <http://bit.ly/SF-Navy>

AGE	MALE	FEMALE
≤19	12:30	15:00
20-24	13:30	15:30
25-29	14:00	16:08
30-34	14:30	16:45
35-39	15:00	17:00
40-44	15:30	17:15

AGE	MALE	FEMALE
45-49	16:08	17:23
50-54	16:45	17:30
55-59	17:09	18:34
60-64	18:52	19:43
65+	20:35	20:52

MARINES

A timed 3 mile run. You control the speed manually. Maximum time allowed to pass the test is shown on the table:

For more detailed information, visit: <http://bit.ly/SF-Marines>

AGE	MALE	FEMALE
≤26	28:00	31:00
27-39	29:00	32:00
40-45	30:00	33:00
46+	33:00	36:00

GERKIN

The **Gerkin** protocol, also known as the fireman's protocol, is a sub-max VO₂ (volume of oxygen) test. The test will increase speed and elevation alternately until you reach 85% of your Max heart rate. The time it takes for you to reach 85% determines the test score (VO₂max) as shown in the chart below. Note: Use a heart rate strap for best results

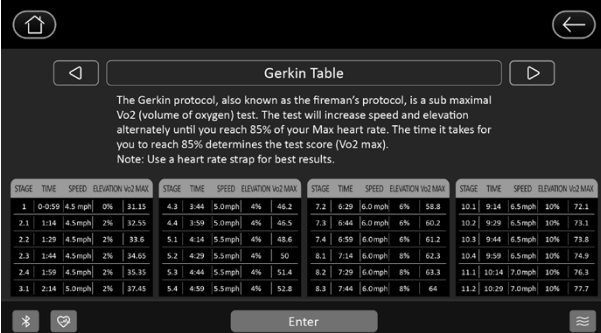

The Gerkin protocol, also known as the fireman's protocol, is a sub maximal Vo₂ (volume of oxygen) test. The test will increase speed and elevation alternately until you reach 85% of your Max heart rate. The time it takes for you to reach 85% determines the test score (Vo₂ max). Note: Use a heart rate strap for best results.

STAGE	TIME	SPEED	ELEVATION	VO ₂ MAX	STAGE	TIME	SPEED	ELEVATION	VO ₂ MAX	STAGE	TIME	SPEED	ELEVATION	VO ₂ MAX	STAGE	TIME	SPEED	ELEVATION	VO ₂ MAX
1	0:55	4.5 mph	0%	21.15	4.3	2:46	5.0 mph	4%	46.2	7.2	6:29	6.0 mph	6%	58.8	10.1	9:14	6.5 mph	10%	72.1
2.1	1:14	4.5 mph	2%	22.35	4.4	3:39	5.0 mph	4%	48.5	7.3	6:44	6.0 mph	6%	60.2	10.2	9:29	6.5 mph	10%	73.1
2.2	1:29	4.5 mph	2%	23.6	5.1	4:14	5.5 mph	4%	48.6	7.4	6:59	6.0 mph	6%	61.2	10.3	9:44	6.5 mph	10%	73.6
2.3	1:44	4.5 mph	2%	24.85	5.2	4:29	5.5 mph	4%	50	8.1	7:14	6.0 mph	6%	62.3	10.4	9:59	6.5 mph	10%	74.9
2.4	1:59	4.5 mph	2%	26.35	5.3	4:44	5.5 mph	4%	53.4	8.2	7:29	6.0 mph	6%	63.3	11.1	10:14	7.0 mph	10%	76.3
3.1	2:14	5.0 mph	2%	27.45	5.4	4:59	5.5 mph	4%	52.8	8.3	7:44	6.0 mph	6%	64	11.2	10:29	7.0 mph	10%	77.7

GERKIN VALUE TABLE

Stage	Time	Speed	Grade	VO2 Max						
1	0 to 1:00	4.5mph	0%	31.15		6.4	6:00	6.0mph	6%	57
2.1	1:00	4.5mph	2%	32.55		7.1	6:15	6.0mph	6%	57.7
2.2	1:30	4.5mph	2%	33.6		7.2	6:30	6.0mph	6%	58.8
2.3	1:45	4.5mph	2%	34.65		7.3	6:45	6.0mph	6%	60.2
2.4	2:00	5.0mph	2%	35.35		7.4	7:00	6.0mph	8%	61.2
3.1	2:15	5.0mph	2%	37.45		8.1	7:15	6.0mph	8%	62.3
3.2	2:30	5.0mph	2%	39.55		8.2	7:30	6.0mph	8%	63.3
3.3	2:45	5.0mph	2%	41.3		8.3	7:45	6.0mph	8%	64
3.4	3:00	5.0mph	4%	43.4		8.4	8:00	6.5mph	8%	65
4.1	3:15	5.0mph	4%	44.1		9.1	8:15	6.5mph	8%	66.5
4.2	3:30	5.0mph	4%	45.15		9.2	8:30	6.5mph	8%	68.2
4.3	3:45	5.0mph	4%	46.2		9.3	8:45	6.5mph	8%	69
4.4	4:00	5.5mph	4%	46.5		9.4	9:00	6.5mph	10%	70.7
5.1	4:15	5.5mph	4%	48.6		10.1	9:15	6.5mph	10%	72.1
5.2	4:30	5.5mph	4%	50		10.2	9:30	6.5mph	10%	73.1
5.3	4:45	5.5mph	4%	51.4		10.3	9:45	6.5mph	10%	73.8
5.4	5:00	5.5mph	6%	52.8		10.4	10:00	7.0mph	10%	74.9
6.1	5:15	5.5mph	6%	53.9		11.1	10:15	7.0mph	10%	76.3
6.2	5:30	5.5mph	6%	54.9		11.2	10:30	7.0mph	10%	77.7
6.3	5:45	5.5mph	6%	56		11.3	10:45	7.0mph	10%	79.1
						11.4	11:00	7.0mph	10%	80

What Your Score Means:

VO2MAX CHART FOR MALES AND VERY FIT FEMALES

Home ENTERTAINMENT PROGRAM DISPLAY INTERNET ←

INCLINE 2.0

You have reached your target heart rate.

% HR

100
95
90
85
80
75
70
65
60

SPEED 5.0

Volume + -

Muscle profile

2.03 km 200 02:45 120 bpm 6:00

Distance Calories Time Elapsed Heart Rate Pace

Bluetooth Heart Rate Simple Track Dashboard Refresh

PEB (PHYSICAL EFFICIENCY

BATTERY)

FOR U.S. FEDERAL LAW

ENFORCEMENT

A timed 1.5 mile run. You control the speed manually. Maximum time allowed to pass the test is shown on the table:

For more detailed information, visit: <https://www.fletc.gov/peb-scores-age-and-gender>

AGE	MALE	FEMALE	AGE	MALE	FEMALE
≤24	10:53	13:36	45-49	13:07	16:02
25-29	11:05	13:43	50-54	13:49	17:02
30-34	11:26	13:43	55-59	14:48	17:37
35-39	11:47	14:37	60+	15:07	17:37
40-44	12:28	15:12			

COAST GUARD

A timed 1.5 mile run. You control the speed manually. Maximum time allowed to pass the test is shown on the table:

AGE	MALE	FEMALE
<30	12:51	15:26
30-39	13:36	15:57
40-49	14:29	16:58
50-59	15:26	17:55
60+	16:40	18:44

HEART RATE PROGRAMS

Heart Rate Control (HRC) uses your treadmill's incline system to control your heart rate via information from pulse grips or wireless chest strap (sold separately). Increases and decreases in elevation affect heart rate much more efficiently than changes in speed alone. The **HRC** program automatically changes elevation gradually to achieve the programmed target heart rate.

Select and begin either the Heart Rate 1 program (HR1), or the Heart Rate 2 program (HR2) by following the directions on page 24.

The Heart Rate program (HR1) will attempt to maintain your heart rate at 65%. The Heart Rate 2 program (HR2) will attempt to maintain your heart rate at 80% of your maximum heart rate (as calculated based on user data entered previously).

Note: When "No Heart Rate Detected" is displayed, no pulse signal is being detected. Please check and make sure that the sensors or heart rate strap is being used as instructed, or check for possible interference.



RATE OF PERCEIVED EXERTION

There are more variables involved in how hard you should workout than just heart rate. Your stress level, physical health, emotional health, temperature, humidity, the time of day, the last time you ate and what you ate, all contribute to the intensity at which you should workout.

The rate of perceived exertion (RPE), also know as the Borg scale, was developed by Swedish physiologist G.A.V. Borg. The scale helps users determine an approximate heart rate level when a heart rate monitor was not in use. Using the scale below, rate the level of intensity of your workout, or the perception of your effort during your workout. Once the rating has been determined, simply add a "0" to the rating to get your approximate heart rate. For example, if your workout felt comfortable, you would rate it a "12". Then add a "0" to get an approximate heart rate during your workout of 120 beats per minute. The scale is as follows:

Rating Perception of Effort

6 Minimal	10 Very light +	14 Somewhat hard +	18 Very hard +
7 Very,very light	11 Fairly light	15 Hard	19 Very,very hard
8 Very,very light +	12 Comfortable	16 Hard +	20 Maximal
9 Very light	13 Somewhat hard	17 Very hard	

TARGET HEART RATE

The old motto, “no pain, no gain”, is a myth that has been overpowered by the benefits of exercising comfortably. A great deal of this success has been promoted by the use of heart rate monitors. With the proper use of a heart rate monitor, many people find that their usual choice of exercise intensity was either too high or too low and exercise is much more enjoyable by maintaining their heart rate in the desired benefit range.

To determine the benefit range in which you wish to train, you must first determine your Maximum Heart Rate. This can be accomplished by using the following formula: 220 minus your age. This will give you the Maximum Heart Rate (MHR) for someone of your age. To determine the effective heart rate range for specific goals you simply calculate a percentage of your MHR. Your Heart rate training zone is 50% to 90% of your maximum heart rate. 65% of your MHR is the recommended for burning fat while 85% is recommended for strengthening the cardio vascular system. This 65% to 85% is the zone to stay in for maximum benefit.

For someone who is 40 years old their target heart rate zone is calculated:
 $220 - 40 = 180$ (maximum heart rate)
 $180 \times .65 = 117$ beats per minute (65% of maximum)
 $180 \times .85 = 153$ beats per minute (85% of maximum)
So for a 40 year old the training zone would be 117 to 153 beats per minute.

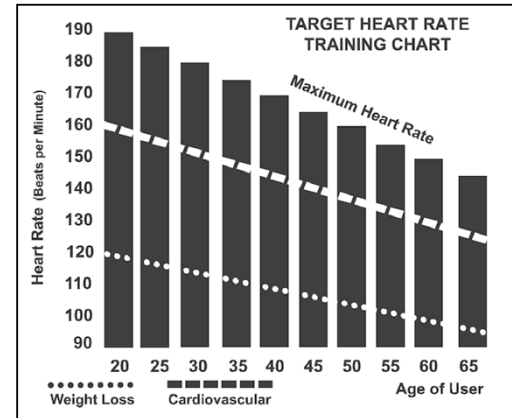

If you enter your age during programming the console will perform this calculation automatically. Entering your age is used for the Heart Rate programs. After calculating your MHR you can decide upon which goal you would like to pursue.

The two most popular reasons for, or goals, of exercise are cardiovascular fitness (training for the heart and lungs) and weight control. The black columns on the chart represent the MHR for a person whose age is listed at the bottom of each column. The training heart rate, for either cardiovascular fitness or weight loss, is represented by two different lines that cut diagonally through the chart. A definition of the lines' goal is in the bottom left-hand corner of the chart. If your goal is cardiovascular fitness or if it is weight loss, it can be achieved by training at 85% or 65%, respectively, of your MHR on a schedule approved by your physician. Consult your physician before participating in any exercise program.

With all Spirit Fitness treadmills you may use the heart rate monitor feature without using the Heart Rate program. However, when using the heart rate monitor feature in conjunction with the Heart Rate programs, the machine will automatically adjust speed or incline to maintain the desired heart rate.

WEARING THE CHEST STRAP (SOLD SEPARATELY)

1. Attach the transmitter to the elastic strap using the interlocking button.
2. Adjust the strap as tightly as possible while ensuring it is still comfortable.
3. Position the transmitter with the logo centered in the middle of your torso facing away from your chest (some people must position the transmitter slightly left of center). Attach the final end of the elastic strap by inserting the round end and, using the locking parts, secure the transmitter and strap around your chest.
4. Position the transmitter directly below the pectoral muscles.
5. Sweat is the best conductor to measure very minute heart beat electrical signals. However, plain water can also be used to pre-wet the electrodes (2 ribbed oval areas on the reverse side of the belt and both sides of the transmitter). It's also recommended that you wear the transmitter strap a few minutes before your work out. Some users, because of body chemistry, have a more difficult time in achieving a strong, steady signal at the beginning. After "warming up", this problem lessens.
6. Your workout must be within range - distance between transmitter/receiver – to achieve a strong steady signal. The length of range may vary somewhat but generally stay close enough to the console to maintain good, strong, reliable readings. Wearing the transmitter directly on bare skin assures you of proper operation. If you wish, you may wear the transmitter over a shirt. To do so, wet the areas of the shirt that the electrodes will rest upon.

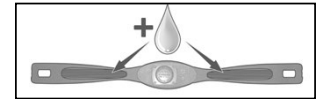
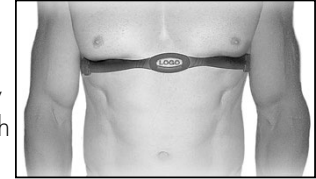

Note: The transmitter is automatically activated when it detects activity from the user's heart. Additionally, it automatically deactivates when it does not receive any activity. Although the transmitter is water resistant, moisture can have the effect of creating false signals, so you should take precautions to completely dry the transmitter after use to prolong battery life (estimated transmitter battery life is 2500 hours). The replacement battery is CR2032. The chest strap is sold separately. Chest straps that operate using Bluetooth should also work with this machine.

ERRATIC OPERATION

Caution! Do not use this treadmill for Heart Rate programs unless a steady, solid Actual Heart Rate value is being displayed. High, wild, random numbers being displayed indicate a problem.

Areas to look for interference which may cause erratic heart rate:

1. Treadmill is not properly grounded.
2. Microwave ovens, TV's, small appliances, etc.
3. Fluorescent lights.
4. Some household security systems.
5. Electric fence for a pet.
6. Some people have problems with the transmitter picking up a signal from their skin. If you have problems try wearing the transmitter upside down. Normally the transmitter will be oriented so the Spirit Fitness logo is right side up.
7. The antenna that picks up your heart rate is very sensitive. If there is an outside noise source, turning the whole machine 90 degrees may de-tune the interference.
8. Another Individual wearing a transmitter within 3' of your machine's console.

If you continue to experience problems contact your dealer.

SAFETY TETHER CORD

A safety tether cord is provided with this unit. It is a simple magnetic design that should be used at all times. It is for your safety should you fall or move too far back on the treadmill. Pulling this safety tether cord will stop treadmill movement. To Use:

1. Place the magnet into position on the round metal portion of the console control head. Your treadmill will not start and operate without this. Removing the magnet also secures the treadmill from unauthorized use.
2. Fasten the plastic clip onto your clothing securely to assure good holding power. *NOTE: The magnet has strong enough power to minimize accidental, unexpected stopping. The clip should be attached securely to make certain it does not come off. Be familiar with its function and limitations. The treadmill will stop, depending on speed, with a one to two step coast anytime the magnet is pulled off the console. Use the **Stop/Pause button** in normal operation.*

CSAFE FEATURE

Your console is equipped with a CSAFE feature. The Power (POWER) port can be used for powering a remote controlled audio-visual system by connecting a cable from the remote to the Power port at the back of the console. The Communication port (COMM) can be used to interact with fitness software applications.

GENERAL MAINTENANCE

Unplug treadmill before performing any maintenance.

Task	How To	Daily	Weekly	Monthly	Semi-Annually
Wipe Down Unit	Damp cloth w/ water	•			
Clean Under Belt	Towel or vacuum			•	
Check Belt Tension/Tracking	Feel/Visual		•		
Clean Under Motor Cover	Vacuum carefully				•
Check Hardware	Wrench			•	
Inspect for Deck Wear	Visual				•
Inspect Drive Belt	Visual				•

SANITIZING YOUR SPIRIT FITNESS EQUIPMENT

- Unupholstered high-contact surfaces (hard plastics) can be sanitized using a 75% isopropyl alcohol solution and a clean, dry cloth. Spray surfaces to be sanitized, and use the dry cloth to wipe clean. Allow surfaces to dry before using.
- For upholstered or soft-plastic surfaces, use a conditioner after sanitizing. Be sure to follow the instructions provided by the conditioner manufacturer to ensure proper use of the conditioner.
- Alternatively, you can make your own spray by mixing the proper ratio of isopropyl alcohol and distilled water to reach a 75% solution.
- For more details on sanitization, or to learn how to make your own spray solution, please visit <https://support.spiritfitness.com/hc/en-us/articles/4406787148564>.

BELT/DECK

Your treadmill uses a very high-efficient and propriety belt/deck combination. Performance is maximized when the deck is kept as clean as possible. Use a soft, damp cloth, or paper towel, wipe the edges of the belt and the area between the belt edge and the frame. Also reach as far as practical directly under the belt edge. This should be done once a moth to extend the bend and deck life. A mild soap and water solution along with a nylon scrub brush will clean the top of the textured belt. Allow to dry before using. The low maintenance (routine monthly cleaning), dual sided deck is designed to withstand up to 4,000 hrs on each side. If the original side of the deck use is over 4,000 hrs, then it will need to be flipped. Contact your service technician for assistance. Do not apply any type of lubricant or wax to the surface.

BELT ADJUSTMENTS

Belt tension is not critical for most users. It is very important though for joggers and runners in order to provide a smooth, steady running surface. Adjustment must be made from the rear roller with the 8mm Allen wrench provided in the parts package. The adjustment bolts are located at the end of the step rails as shown in the diagram below.

Tighten the rear roller only enough to prevent slippage at the front roller. Turn the tread-belt tension adjusting bolts $1/4$ turn each and inspect for proper tension by walking on the belt and making sure it is not slipping or hesitating with each step. When an adjustment is made to the belt tension, you must be sure to turn the bolts on both sides evenly or the belt could start tracking to one side instead of running in the middle of the deck.

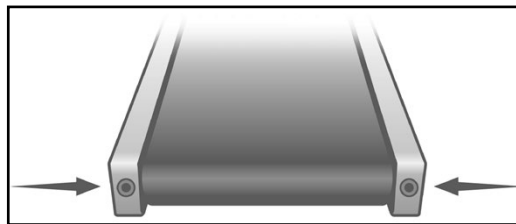

DO NOT OVER TIGHTEN – Over tightening will cause belt damage and premature bearing failure. If you tighten the belt a lot and it still slips, the problem could actually be the drive belt - located under the motor cover - that connects the motor to the front roller. If that belt is loose it feels similar to the walking belt being loose. Tightening the motor belt should be done by a trained service person.

TREADBELT TRACKING ADJUSTMENT

The treadmill is designed so that the tread-belt remains reasonably centered while in use. It is normal for some belts to drift near one side while in use, depending on a user's gait and if they favor one leg. But if during use the belt continues to move toward one side, adjustments are necessary.

Setting Tread-Belt Tracking:

An 8mm Allen wrench is provided for this adjustment. Make tracking adjustments on the left side bolt. Set belt speed at 3 mph. Be aware that a small adjustment can make a dramatic difference which may not be apparent right away. If the belt is too close to the left side, then turn the bolt only a 1/4 turn to the right (clockwise) and wait a few minutes for the belt to adjust itself. Continue to make 1/4 turns until the belt stabilizes in the center of the running deck.

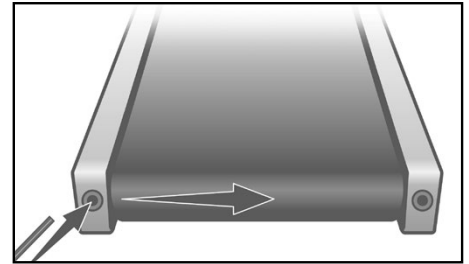

If the belt is too close to the right side, turn the bolt counter-clockwise. The belt may require periodic tracking adjustment depending on use and walking/running characteristics. Some users may affect tracking differently. Expect to make adjustments as required to center the tread-belt. Adjustments will become less of a maintenance concern as the belt is used. Proper belt tracking is an owner responsibility common with all treadmills.

ATTENTION: Damage to the running belt resulting from improper tracking / tension adjustments is not covered under the Spirit Fitness warranty.

ADJUSTING THE SPEED SENSOR

If the calibration does not pass you may need to check the speed sensor alignment.

1. Remove the motor cover hood by loosening the 8 screws that hold it in place. Set it aside.
2. The speed sensor is located on the left side of the frame, right next to the front roller pulley (the pulley will have a belt around it that also goes to the motor). The speed sensor is a small rectangular shaped black box with a wire connected to it.
3. You will see a magnet on the outside edge of the pulley; make sure the speed sensor is aligned with the center of the magnet when it passes by. There are two screws that hold the sensor in place that need to be loosened to adjust the sensor. Re-tighten the screws when finished.



TROUBLESHOOTING

PROBLEM	CAUSE
Display does not light	<ol style="list-style-type: none"> 1. Tether cord not in position. 2. Circuit breaker on front grill tripped. Push circuit breaker in until it locks. 3. Plug is disconnected. Make sure plug is firmly pushed into 115 VAC wall outlet. 4. Breaker panel circuit breaker may be tripped. 5. Treadmill defect. Contact your Spirit Fitness dealer.
Treadbelt does not stay centered Treadmill belt hesitates when walked/run on	The user may be walking while favoring or putting more weight on either the left or right foot. If this walking pattern is natural, track the belt slightly off-center to the side opposite from the belt movement. See General Maintenance section on Treadbelt Tension . Adjust as necessary.
Motor is not responsive after pressing start	<ol style="list-style-type: none"> 1. If the belt moves, but stops after a short time and the display shows "LS", run calibration. 2. If you press start and the belt never moves, then the display shows LS, contact service.
Circuit breaker trips, but not the treadmill circuit breaker	Need to replace the breaker with a "High In-rush current" type breaker (see page 4 for details)
Treadmill will only achieve approximately 12 mph but shows higher speed on display	This indicates motor should be receiving power to operate. Do not use an extension cord. If an extension cord is required, it should be as short as possible and heavy duty, 16-gauge minimum, low voltage. Contact an electrician or your Spirit Fitness dealer. A minimum of 110-volt AC current is required.
Treadbelt stops quickly/suddenly when tether cord is pulled	High belt/deck friction. If cleaning doesn't prevent this from reoccurring, check to see if there is significant wear of the deck. If so, the deck may need to be flipped if it is on its original side.
Treadmill trips on board 20 amp circuit	High belt/deck friction. If cleaning doesn't prevent this from reoccurring, check the amp draw of the motor. If this is high and there are signs of significant wear of the deck, it may need to be flipped on its original side.
Computer shuts off when console is touched (on a cold day) while walking/running	Treadmill may not be grounded. Static electricity is crashing the computer. Refer to Grounding Instructions .

TREADMILL WARRANTY EFFECTIVE MARCH 15, 2024

Spirit Fitness warrants all its treadmill parts for a period of time listed below from the date of retail sale, as determined by sale receipt, or in the absence of a sales receipt eighteen (18) months from the original factory shipping date. Spirit Fitness' responsibilities include providing new or remanufactured parts, at Spirit Fitness' option, and technical support to our independent dealers and servicing organizations. In the absence of a dealer or service organization, these warranties will be administered by Spirit Fitness directly to a facility. The warranty period applies to the following components:

WARRANTY	FRAME	MOTOR & DECK	PARTS	LABOR	CONSOLE PARTS:	CONSOLE LABOR:
Commercial (Non-Dues Paying Facilities)	Lifetime	5 Years	5 Years	2 Years	3 Years	1 Year
Residential	Lifetime	Lifetime	10 Years	2 Years	3 Years	1 Year

*Prisons and correctional facilities are excluded from warranty coverage.

NORMAL RESPONSIBILITIES OF THE FACILITY

The non-dues paying facility is responsible for the items listed below:

1. The warranty registration card must be completed and returned to the address listed on the card within 10 days of the original purchase, or completed online to validate the manufacturer's limited warranty.
2. Proper use of the fitness equipment in accordance with the instructions provided in this manual
3. Proper installation in accordance with instructions provided with the fitness equipment and with all local electric codes.
4. Proper connection to a grounded power supply of sufficient voltage, replacement of blown fuses, repair of loose connections or defects in house or facility wiring.
5. Expenses for making the fitness equipment accessible for servicing, including any item that was not part of the fitness equipment at the time it was shipped from the factory.
6. Damages to the fitness equipment finish during shipping, installation or following installation.
7. Routine maintenance of this unit as specified in this manual.

EXCLUSIONS

This warranty does not cover the following:

1. CONSEQUENTIAL, COLLATERAL, OR INCIDENTAL DAMAGES SUCH AS PROPERTY DAMAGE AND INCIDENTAL EXPENSES RESULTING FROM ANY BREACH OF THIS WRITTEN OR ANY IMPLIED WARRANTY.
NOTE: Some states do not allow the exclusion or limitation of incidental or consequential damages, so this limitation or exclusion may not apply to you.
2. Service call reimbursement to the consumer. Service call reimbursement to the dealer that does not involve malfunction or defects in workmanship or material, for units that are beyond the warranty period, for units that are beyond the service call reimbursement period, for fitness equipment not requiring component replacement, or fitness equipment not in non-dues paying facility or household use.
3. Damages caused by services performed by persons other than authorized Spirit Fitness service companies; use of parts other than original Spirit Fitness parts; or external causes such as corrosion, discoloration of paint or plastic, alterations, modifications, abuse, misuse, accident, improper maintenance, inadequate power supply, or acts of God.
4. Products with original serial numbers that have been removed or altered.
5. Products that have been: sold, transferred, bartered, or given to a third party.
6. Products that do not have a warranty registration card on file at Spirit Fitness. Spirit Fitness reserves the right to request proof of purchase if no warranty record exists for the product.
7. THIS WARRANTY IS EXPRESSLY IN LIEU OF ALL OTHER WARRANTIES EXPRESSED OR IMPLIED, INCLUDING THE WARRANTIES OF MERCHANTABILITY AND/OR FITNESS FOR A PARTICULAR PURPOSE.
8. Product used in a dues paying facility (YMCA, Health Club, Etc.)
9. Product used in prisons and correctional facilities
10. Warranties outside of the United States may vary. Please contact your local dealer for details.

SERVICE

Keep your bill of sale. Twelve (12) months from the date on the bill of sale or eighteen (18) months from the date of factory shipping as determined by the serial number establishes the labor warranty period should service be required. If service is performed, it is in your best interest to obtain and keep all receipts. This written warranty gives you specific legal rights. You may also have other rights that vary from state to state. Service under this warranty must be obtained by following these steps, in order:

1. Contact your selling authorized Spirit Fitness dealer. OR
2. Contact your local authorized Spirit Fitness service organization.
3. If there is a question as to where to obtain service, contact our service department at (870) 935-1107.
4. Spirit Fitness' obligation under this warranty is limited to repairing or replacing, at Spirit Fitness' option, the product through one of our authorized service centers. All repairs must be preauthorized by Spirit Fitness. If the product is shipped to a service center freight charges to and from the service center will be the customer's responsibility. For replacement parts shipped while the product is under warranty, the customer will be responsible for shipping and handling charges. For in-home service, the customer will be responsible for a trip charge. There will be an additional trip charge if the customer is located over 100 miles from the nearest service center.
5. The owner is responsible for adequate packaging upon return to Spirit Fitness. Spirit Fitness is not responsible for damages in shipping. Make all freight damage claims with the appropriate freight carrier. **DO NOT SHIP ANY UNIT TO OUR FACTORY WITHOUT A RETURN AUTHORIZATION NUMBER.** All units arriving without a return authorization number will be refused.
6. For any further information, or to contact our service department by mail, send your correspondence to:

SPIRIT FITNESS, INC.
P.O. Box 2037
Jonesboro, AR 72402-2037

Product features or specifications as described or illustrated are subject to change without notice. All warranties are made by Spirit Manufacturing, Inc. This warranty applies only in the 48 contiguous United States. NOTE: This does not apply to Alaska or Hawaii.

Optional

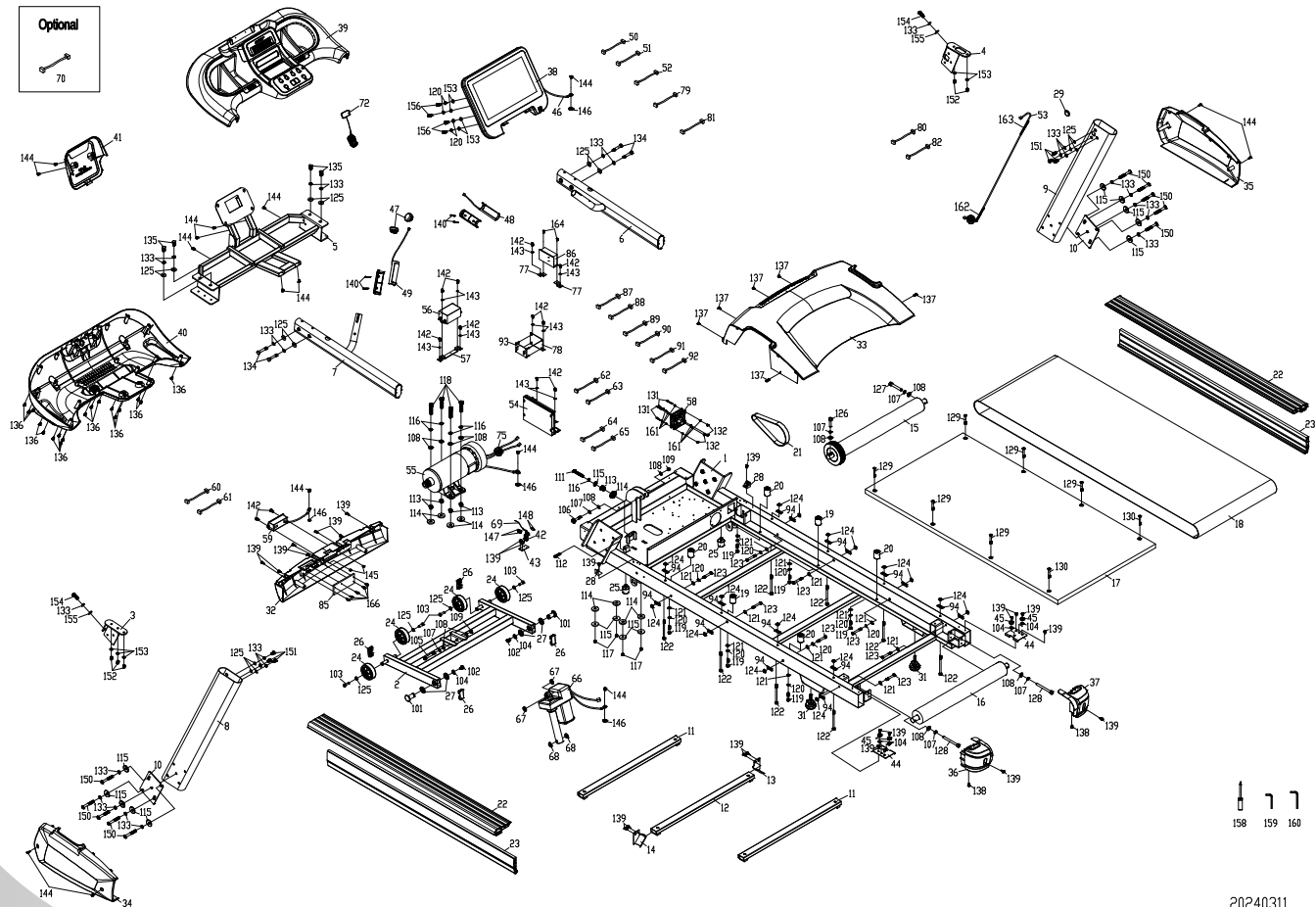

20240311

CT800ENT Part List_SPIRIT		
1	Main Frame	1
2	Incline Bracket	1
3	Locking Plate Assembly (L)	1
4	Locking Plate Assembly (R)	1
5	Console Support	1
6	Handle Bar (R)	1
7	Handle Bar (L)	1
8	Left Upright	1
9	Right Upright	1
10	Upright Fixing Plate	2
11	Running Deck Stabilizer Assembly(A)	2
12	Running Deck Stabilizer Assembly(B)	1
13	Belt Guide(R)	1
14	Belt Guide(L)	1
15	Front Roller W/Pulley	1
16	Rear Roller	1
17	Running Deck	1
18	Running Belt	1
19	Cushion A	2
20	Cushion B	4
21	Drive Belt	1
22	Foot Rail(Upper)	2
23	Foot Rail	2
24	Transportation Wheel	4
25	Incline Rubber Foot	2
26	25m/m x 50m/m Square End Cap	4
27	Stable Wheel Spacer	4
28	Motor Cover Anchor(D)	2
29	Round Cap	1
31	Foot Pad	2
32	Front Motor Cover	1
33	Motor Top Cover	1
34	Motor Base Cap (L)	1
35	Motor Base Cap (R)	1
36	Rear Adjustment Base (L)	1
37	Rear Adjustment Base (R)	1
38	Console Assembly	1

39	Rack Top Cover	1
40	Rack Bottom Cover	1
41	Console Cover	1
42	Hall Sensor Rack	1
43	Hall Sensor	1
44	Adjustment Rail Pad	2
45	Rubber Foot Pad	4
46	300m/m Ground Wire	1
47	Handpulse End Cap	2
48	900m/m Handpulse W/Cable Assembly(SMP-03)	1
49	900m/m Handpulse W/Cable Assembly	1
50	400m/m Handpulse Wire (Upper)(XHB-4)	1
51	400m/m Handpulse Wire (Upper)(XHB-3)	1
52	1100m/m Computer Cable	1
53	1800m/m Computer Cable	1
54	DC digital control	1
55	Drive Motor	1
56	Filter	1
57	Filter Plate	1
58	Fan	1
59	AC Electronic Module	1
60	450m/m Connecting Wire (White)	1
61	450m/m Connecting Wire (Black)	1
62	250m/m Connecting Wire (White)	1
63	250m/m Connecting Wire (Black)	1
64	400m/m Motor Fan Connecting Cable-Black	1
65	400m/m Motor Fan Connecting Cable-White	1
66	Incline Motor	1
67	Ø10 x Ø25 x 0.8T Nylon Washer	2
68	Ø10 x Ø25 x 2.5T Nylon Washer	2
69	1300m/m Sensor W/Cable	1
70	Power Cord	1
72	Square Safety Key	1
75	Ø35 x 21 x 13L Ferrite Core	1
77	Plate	2
78	L-Plate	1
79	900m/m CSAFE Connecting Cable(Upper)	1
80	2400m/m CSAFE Connecting Cable(Lower)	1
81	900m/m Connecting Wire(Upper)	1

82	2400m/m Connecting Wire(Lower)	1
85	Board	1
86	Power Adaptor	1
87	200m/m Connecting Wire (White)	1
88	200m/m Connecting Wire (Black)	1
89	200m/m Connecting Wire	1
90	250m/m Connecting Wire(Red)	1
91	250m/m Connecting Wire (White)	1
92	250m/m Connecting Wire (Black)	1
93	Interface Board	1
94	Ø30 x 14 x 1.5T x 3.5H Concave Washer	16
101	Ø18 x Ø19 x 41L Carriage Bolt	2
102	M8 x 12m/m Hex Head Bolt	2
103	3/8" x 25m/m Hex Head Bolt	4
104	Ø8.5 x Ø26 x 2.0T Flat Washer	6
105	M10 x 65m/m Hex Head Bolt	1
106	M10 x 50m/m Hex Head Bolt	1
107	Ø10 x 1.5T Split Washer	6
108	Ø3/8" x Ø19 x 1.5T Flat Washer	12
109	M10 x P1.5 x 8T Nylon Nut	2
111	3/8" x 2-1/2" Hex Head Bolt	1
112	3/8" x UCN16 x 2" Socket Head Cap Bolt	1
113	Bushing(Ø10xØ14x14L)	5
114	Ø13 x Ø35 x 5T Nylon Washer	9
115	Ø3/8" x 35 x 2.0T Flat Washer	15
116	Ø10 x 2.0T Split Washer	5
117	3/8" x 7T Nylon Nut	4
118	3/8" x UCN x 2" Socket Head Cap Bolt (33L)	4
119	M8 x P1.25 x 40m/m Socket Head Cap Bolt	6
120	5/16" x 1.5T Split Washer	14
121	Ø5/16" x 16 x 1.0T Flat Washer	14
122	M8 x 1.25 x 95m/m Button Head Socket Bolt	8
123	M8 x 55m/m Hex Head Bolt	8
124	M8 x 1.25 x 6.5T Square Nut	16
125	Ø3/8" x Ø25 x 2.0T Flat Washer	18
126	M10 x 40m/m Socket Head Cap Bolt	1
127	M10 x 80m/m Socket Head Cap Bolt	1
128	M10 x 100m/m Socket Head Cap Bolt	2
129	M8 x P1.25 x 55L Flat Head Countersink Bolt	6

130	M8 x 35m/m Flat Head Countersink Bolt	2
131	M3 x 50m/m Phillips Head Screw	4
132	M3 x 5T Nylon Nut	4
133	Ø10 x 2T Split Washer	26
134	3/8" x 2-1/4" Hex Head Bolt	4
135	3/8" x 3/4" Hex Head Bolt	4
136	3.5 x 12m/m Sheet Metal Screw	18
137	5 x 12m/m Sheet Metal Screw	6
138	5 x 25m/m Tapping Screw	2
139	5 x 20m/m Tapping Screw	25
140	3 x 25m/m Tapping Screw	4
142	M5 x 12m/m Phillips Head Screw	12
143	Ø5 x 1.5T Split Washer	10
144	M5 x 12m/m Phillips Head Screw	16
145	M5 x 5T Nylon Nut	2
146	M5 Star Washer	4
147	3.5 x 12m/m Tapping Screw	2
148	M3 x 12m/m Tapping Screw	2
150	3/8" x 3" Button Head Socket Bolt	10
151	3/8" x 3/4" Button Head Socket Bolt	6
152	M8 x 12m/m Socket Head Cap Bolt	5
153	Ø8 x Ø16 x 2T Flat Washer	9
154	3/8" x UNC16 x 1-1/4" Button Head Socket Bolt	2
155	Ø10 x Ø23 x 1.5T Curved Washer	2
156	M8 x P1.25 x 20L Socket Head Cap Bolt	4
158	Phillips Head Screw Driver	1
159	L Allen Wrench(6x25x67L)	1
160	L Allen Wrench(6x26Lx76L)	1
161	Isolation Pad	8
162	Ending Tape(400m/m)	1
163	Ending Tape(200m/m)	1
164	M3 x 10m/m Phillips Head Screw	2
166	3 x 10m/m Sheet Metal Screw	5
230809		



800.258.4555
spiritservice@spiritfitness.com
www.spiritfitness.com



Spirit Fitness
3000 Nestle Road
Jonesboro, AR 72401



CT800ENT Owners Manual
© 2024 All Rights Reserved
Revision 6: 03.15.2024