



## X3 SPATHA PRO ALL-IN-ONE STRENGTH TRAINER

**The Legion X3 Spatha Pro All-In-One Strength Trainer is the perfect all-in-one home gym.**

This essential machine can provide your home gym with one piece that allows you to achieve multiple exercises, movements & results. All your workouts can be done with ease and in the comfort of your home by this one machine.

## X3 SPATHA PRO ALL-IN-ONE STRENGTH TRAINER

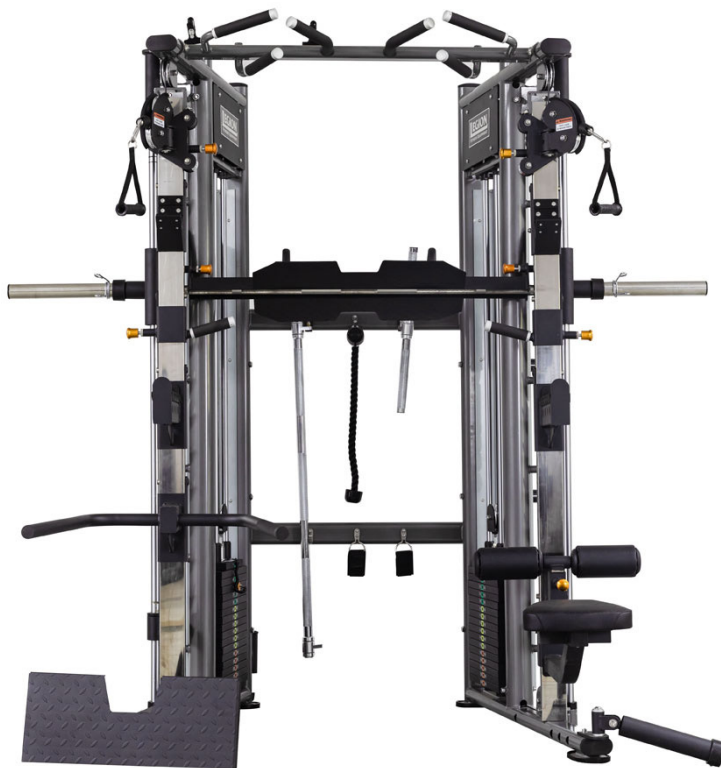

### Product Highlights

- Aluminum Pulleys
- Seated Row Footplate
- Lat Pulldown Seat
- Inverted Leg Press Plate
- Low Row
- TRX Anchor
- J Hooks
- Cable Attachment
- Spotter Arms
- Land Mine
- Dip Bar
- Band Pegs

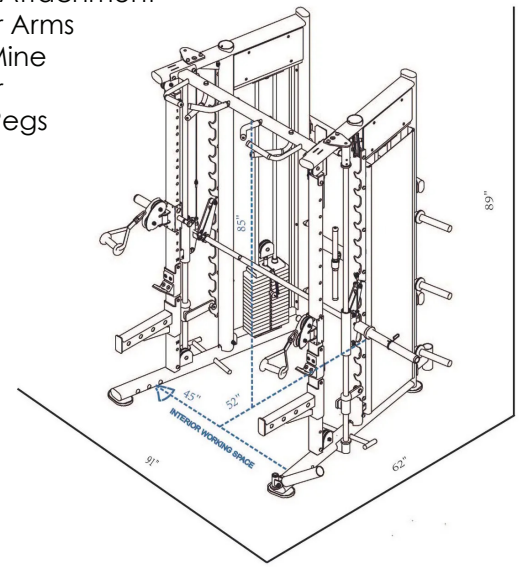

## PRODUCT FEATURES

The Legion X3 Spatha Pro All-In-One Strength Trainer features a dual adjustable pulley system, Smith Machine, multi-grip pull up bars, weight pegs and bar storage, Inverted leg press add on & so much more. This All-In-One Strength Trainer is constructed of heavy gauge rolled steel tubing, high quality cables and pulleys, and 2x 220lb Steel Stack Weight Plate sets. The counter balanced bar for the Smith Machine, lets you accurately control how much weight you want to train with.

By the limitless exercise options and movements, this machine pushes you to achieve your fitness goals and see real results. The high-quality cables and pulleys allow you to complete your exercises smoothly. This weight system gives you a wide range of weight choices for diverse sets of exercises.

## PRODUCT SPECIFICATIONS

<b>SKU:</b>	LC-X3
<b>Base Dimensions</b>	L 85 x W 49 x H 84 in (157 cm x 231 cm x 226 cm)
<b>Base Weight:</b>	1496 lb/679 kg
<b>Frame</b>	Rolled Oval Steel Tubing
<b>Finish:</b>	Powder Coated - Dark Gloss Gray
<b>Weight Stack:</b>	(2) 220 lb stacks
<b>Pulleys:</b>	Aluminum
<b>Guide Rods:</b>	3/4" solid steel
<b>Pulleys:</b>	Aluminum
<b>Adjustable Height:</b>	15 Positions
<b>Weight Pegs:</b>	Yes
<b>Accessories Included:</b>	2X handles, Tricep Bar, Lat Pulldown Bar, and Ankle Strap

### WARRANTY:

**10 years:** Frame

**2 years:** Cables, Pulleys, Weight Plates, Bushings, & guide rods

**90 days:** Upholstery, finish, pull pins, rubber grips, & all other parts