



G9 HYBRID MULTIGYM

Traditional home gym platform providing full body machine based movements.

- Adjustable seat height and seat back.
- Leg extension and standing leg curl with low pulley and adjustable foam leg rollers.
- Adjustable press and row bar.
- Mid pulley station.
- Unique "Radius" frame design.
- 200 lbs. center drilled steel weight stack.
- Optional LC-GLP Leg Press Attachment.

LC-G9 - G9 HYBRID MULTIGYM



Product Highlights

- Adjustable seat height and seat back.
- Leg extension and standing leg curl with low pulley and adjustable foam leg rollers.
- Adjustable press and row bar.
- Mid pulley station.
- Unique "Radius" frame design.
- 200 lbs. center drilled steel weight stack.

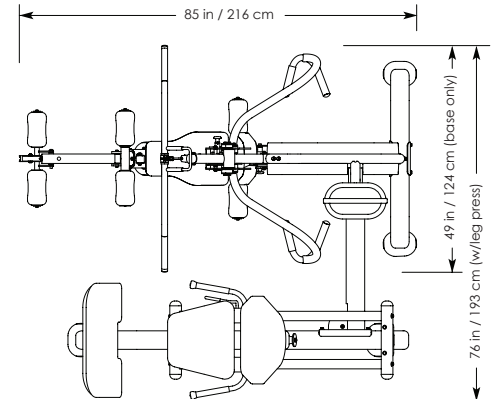

HT: 84 in / 213cm
WT (Base Unit): 550 lb / 249 kg | WT (Leg Press): 190 lb / 86 kg

*Shown with optional
LC-GLP Leg Press*

PRODUCT FEATURES

The Legion G9 Hybrid Multigym combines popular functional training with a traditional arm press and leg station, offering the best of both worlds. With six preset pulleys in three separate training zones (high, mid, and low), the hybrid home gym is fully adjustable. The G9 Hybrid comes equipped with a center-drilled 200 lbs steel weight stack, adjustable seat height and seat back, adjustable press and row bar, and leg extension and standing leg curl with low pulley and adjustable foam leg rollers.

Looking to also do leg workouts? Add the optional Legion LC-GLP Leg Press as an option for this incredible gym. Now you can experience a commercial level leg press on the most premium home gym ever made by Legion!

PRODUCT SPECIFICATIONS

SKU:	LC-G9
Base Dimensions	L 85 x W 49 x H 84 in (L 216 x W 124 x H 213 cm)
Base Weight:	550 lb/249 kg
Frame:	2x3" 11-gauge oval tubular steel with a combination of 2x2" round tubing
Finish:	Powder Coated finish
Upholstery:	Standard black upholstery and double-stitched with "hidden" borders.
Bearings:	1" solid steel pivot axles with non-friction 2" sealed bearings
Guide Rods:	3/4" solid steel
Pulleys:	3/16" and 1/8" high performance fitness cable

WARRANTY:

10 years: Frame

2 years: Cables, Pulleys, Weight Plates, Bushings, & guide rods

90 days: Upholstery, finish, pull pins, rubber grips, & all other parts