



---

**SURVIVOR**®  
**SPORTFLOOR**

**ROLLS • TILES**



## Specifications

Item	Standard	Rating
Density	ASTM E96	68.3lbs/cubic feet
Tensile Strength	ASTM D412	265 psi
Tear Resistance	ASTM D413	Average elongation at break 1.52
Hardness	D2240	Shore A 65 +/- 5
Slip Resistance	D C1028	Coefficient of Friction .084-.090
Abrasion	D4060	2,000 cycles taber abraser 1kg, 0.329g - 0.35g loss
Flammability	ASTM E648	Critical Radiant Flux <0.10W/cm2
Chemicals	N/A	Resistant to most acids and chlorine
Volatile Organic Compounds	CDPH v1.2	<.05mg/m3

## Survivor products contribute up to **5 POINTS** in two LEED categories

- MR - Building Product Disclosure and Optimization: Environmental Product Declarations (Option 1)
- MR - Building Product Disclosure and Optimization: Environmental Production Declarations (Option 2)
- MR - Building Product Disclosure and Optimization: Sourcing of Raw Materials
- MR - Building Product Disclosure and Optimization: Material Ingredients
- EQ - Low Emitting Materials



Our mission is to empower our committed employees, many seeking a second chance in their life and career, so they can responsibly increase demand for products manufactured with raw materials diverted from a waste stream, creating a second life for such materials and reducing the need for virgin materials, and by doing so, will improve the economic vitality and environmental sustainability of our community.



[www.usrubber.com](http://www.usrubber.com)  
[info@usrubber.com](mailto:info@usrubber.com)  
(833) US RUBBER (877-8223)

# Isometrics

- Standard with 10% color fleck
- 19 color choices available

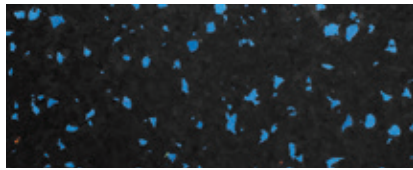

Blue 109

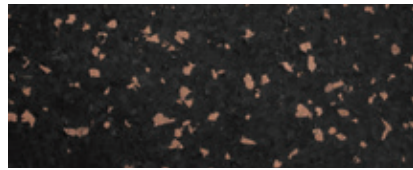

Brown 89

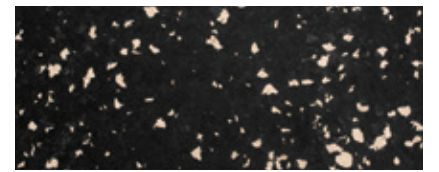

Beige 93

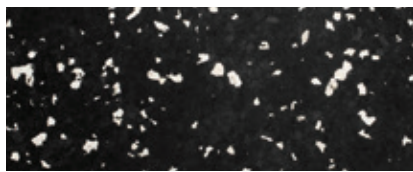

Chrome 110

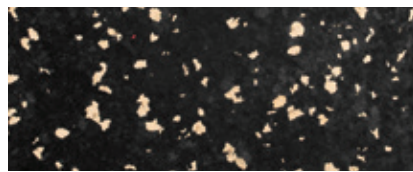

Cream 98

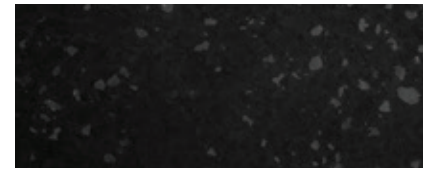

Charcoal 114

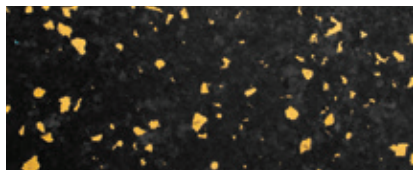

Gold 88

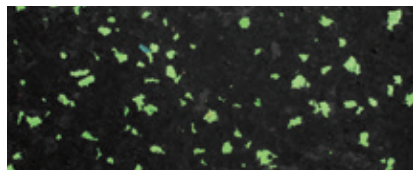

Green 91

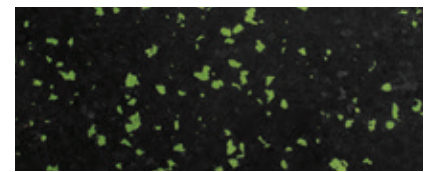

Forest 90

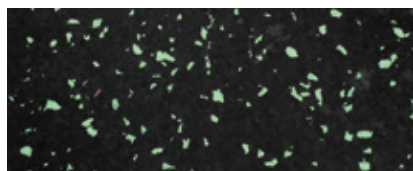

Light Green 108

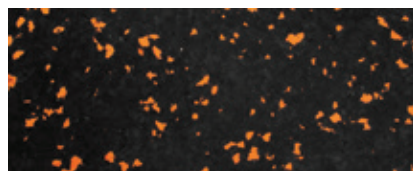

Orange 104

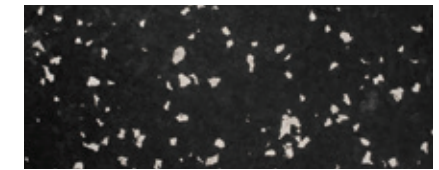

Grey 82

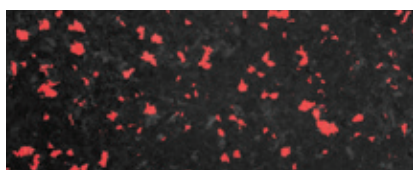

Red 96

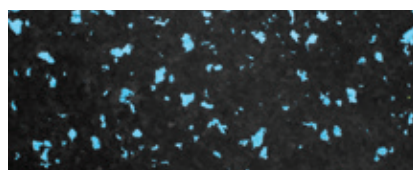

Spa 85

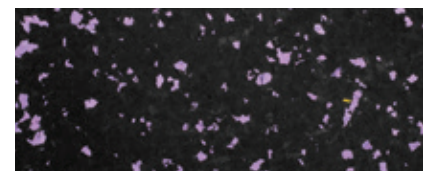

Purple 92

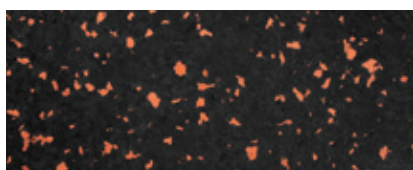

Terra 80

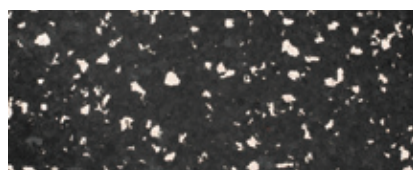

White 94

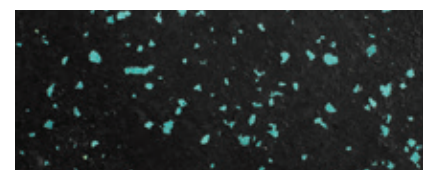

Teal 100

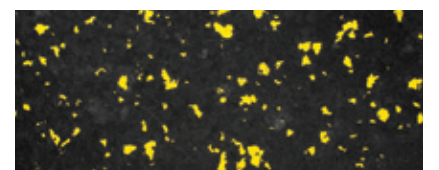

Yellow 83

# Cross Training

- Standard with 20% color fleck
- 16 pre-designed color blends



**Carnival**  
80, 88, 91, 93, 96, 109



**Desert Storm**  
89, 93

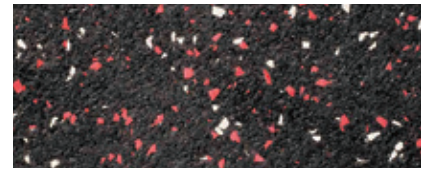

**Brick-n-Mortar**  
80, 94

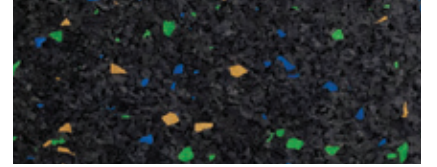

**Electrolyte**  
88, 91, 109

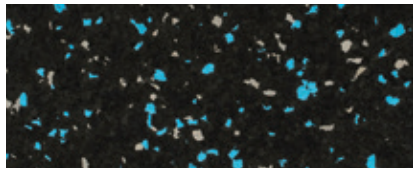

**Extreme Serene**  
82, 85

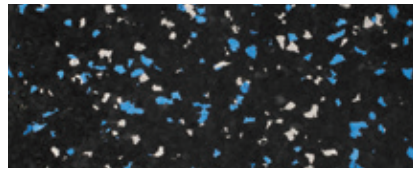

**Glacier**  
82, 109

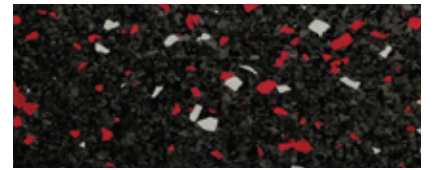

**In the Zone**  
96, 110



**Margarita**  
91, 94

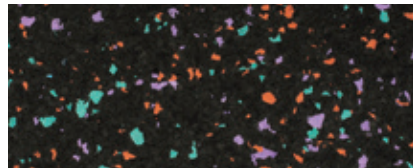

**Miami Muscle**  
80, 92, 100

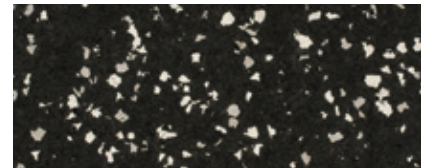

**Nerves of Steel**  
82, 110



**Patriot**  
96, 109, 110

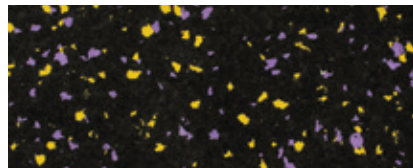

**Planet Hollywood**  
83, 92



**Sea-n-Sand**  
94, 109

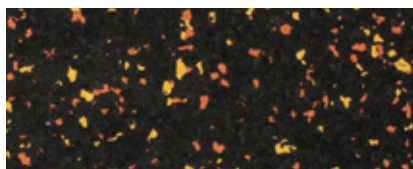

**Trailblazer**  
80, 88



**Trophy**  
93, 94

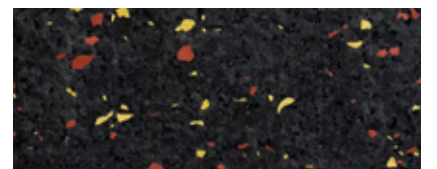

**Vision Quest**  
80, 83



- Standard with 85% color fleck
- 2-4 color fleck blends

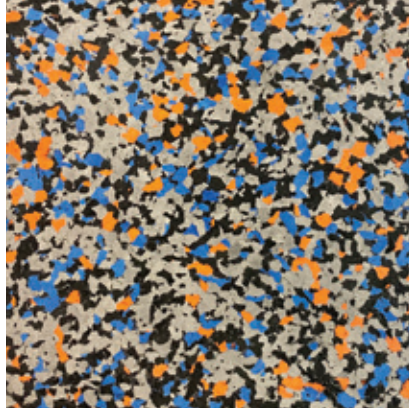

**Bronco**  
82, 104, 109

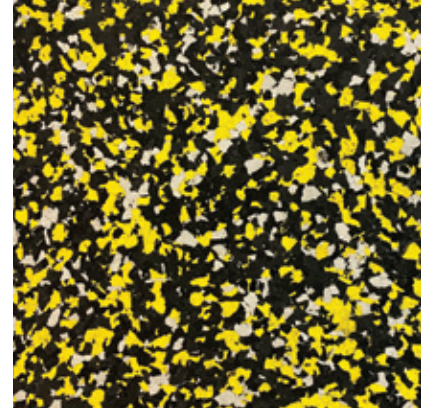

**Bumblebee**  
82, 83

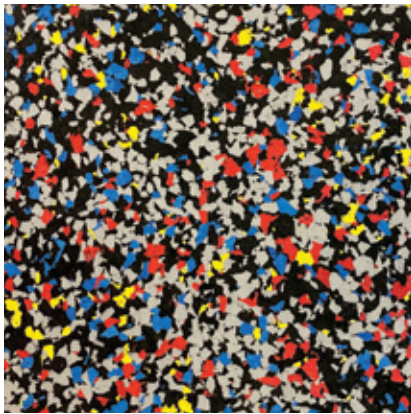

**Celebration**  
82, 83, 96, 109

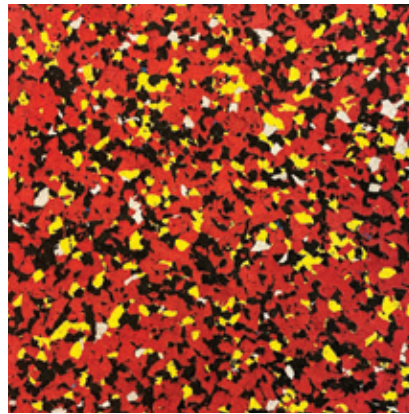

**Del Sol**  
83, 96, 110

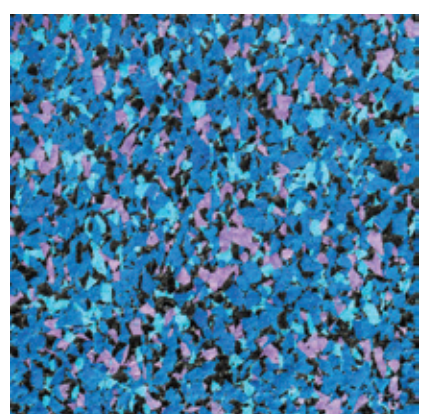

**High Dive**  
85, 92, 109

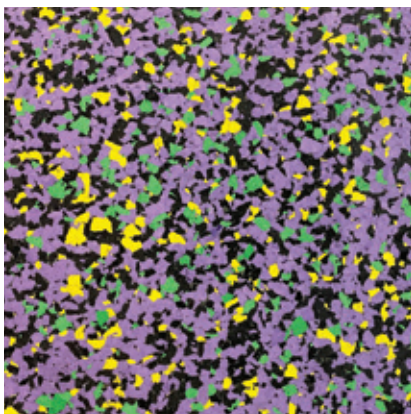

**Mardi Gras**  
83, 91, 92

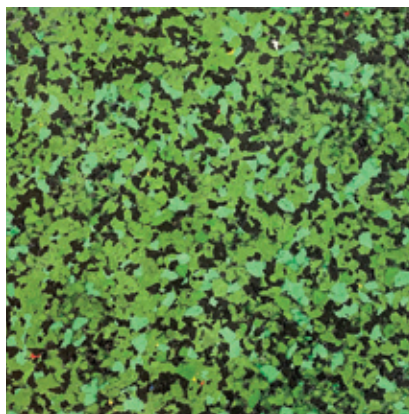

**Smash**  
90, 91



**Surf's Up**  
93, 94, 98, 109



- Standard with 20% color fleck
- Combines BigChip™ with regular fleck

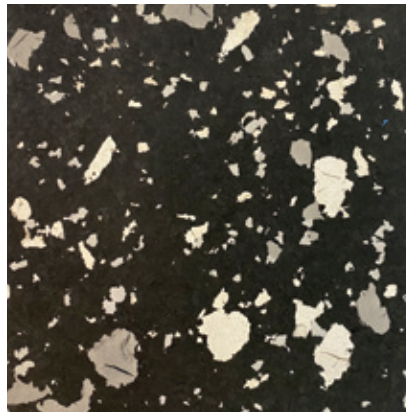

**Avalanche**

82, 82-BC, 110, 110-BC

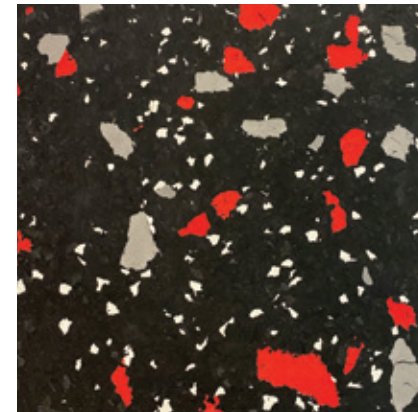

**Buckeye**

82-BC, 96-BC, 110

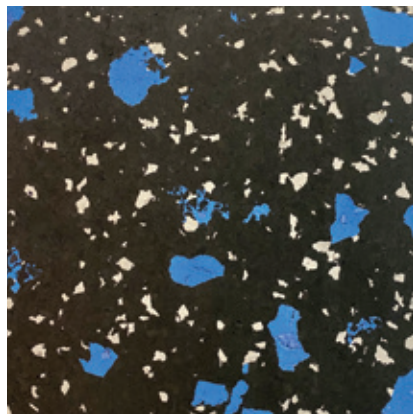

**Iceberg**

82, 109-BC

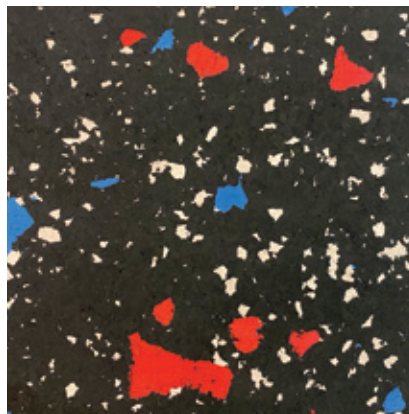

**Merica**

94, 96-BC, 109-BC

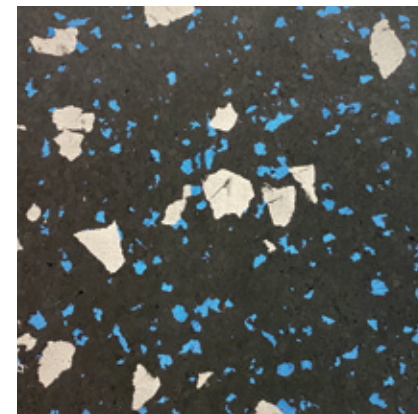

**Polar**

82-BC, 109

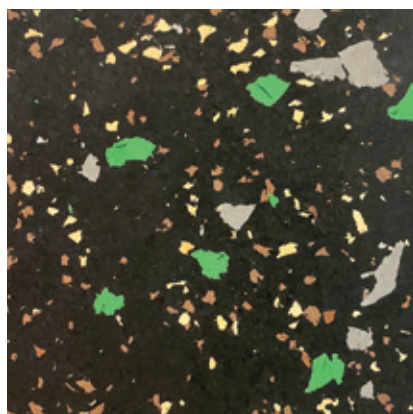

**Rambo**

82-BC, 88, 89, 91-BC

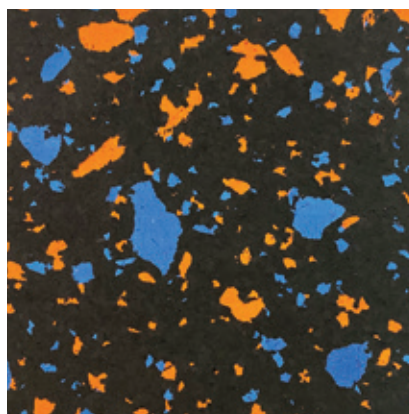

**Stallion**

104, 104-BC, 109, 109-BC

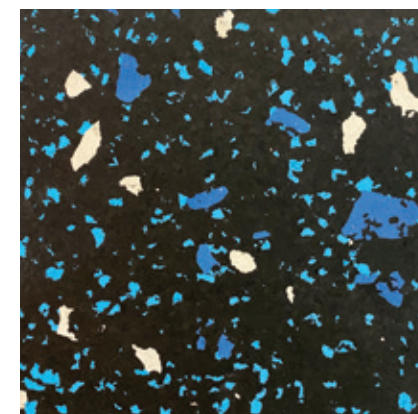

**Tighten Up**

85, 109-BC, 110-BC



- Standard with 20% color fleck
- 2-3 times larger than regular fleck

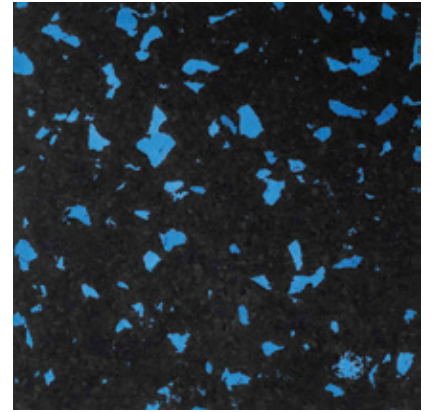

**Blue** 109-BC

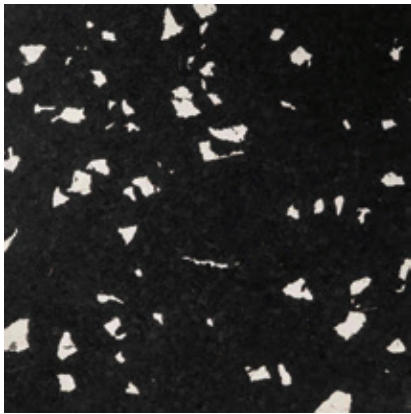

**Chrome** 110-BC

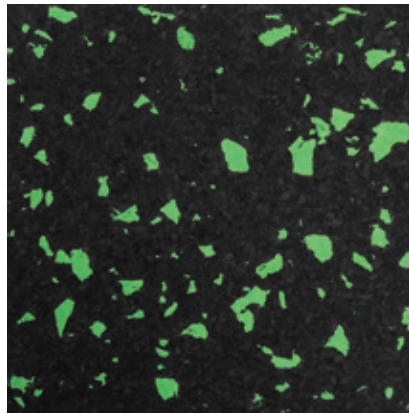

**Green** 91-BC

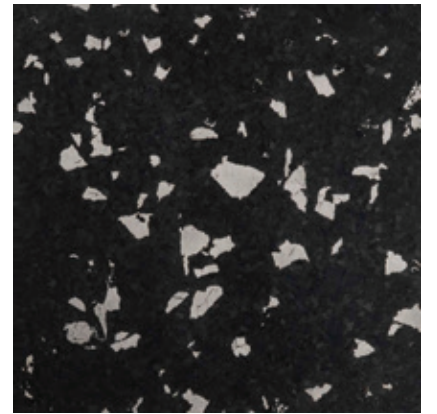

**Grey** 82-BC

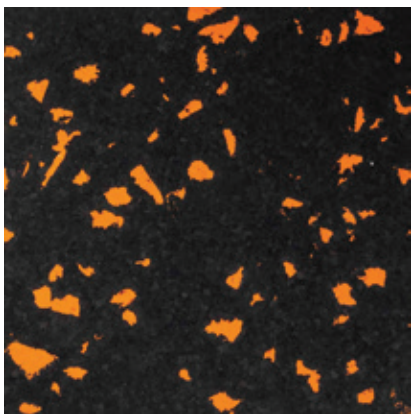

**Orange** 104-BC

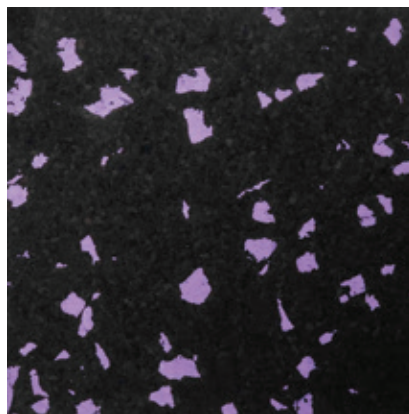

**Purple** 92-BC

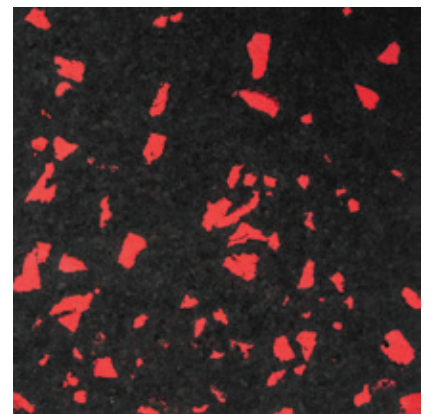

**Red** 96-BC

# Color Options



Beige 93

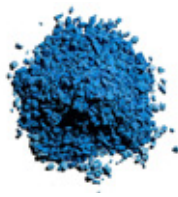

Blue 109



Brown 89



Charcoal 114

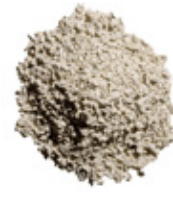

Chrome 110



Cream 98



Forest 90



Gold 88



Green 91



Grey 82



Lt Green 108



Orange 104



Purple 92



Red 96

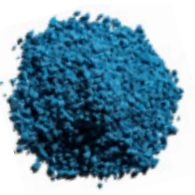

Spa 85

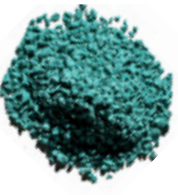

Teal 100



Terra 80



White 94



Yellow 83

# Color Gradient

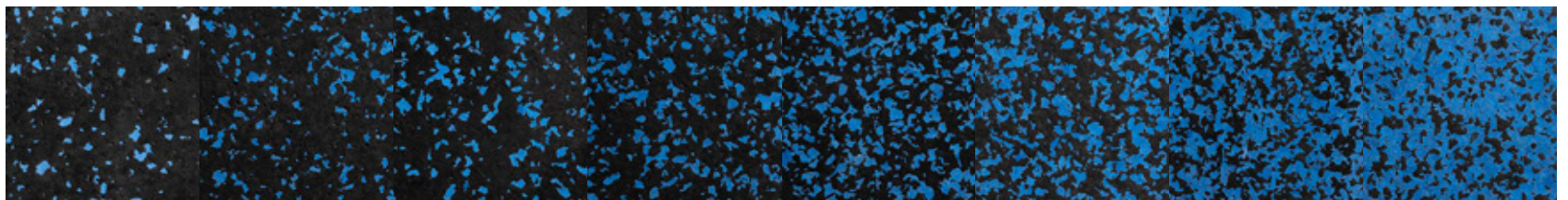

10%

20%

30%

40%

50%

60%

70%

85%

# 25 Year Limited Warranty

U.S. Rubber Recycling warrants to the first purchaser for use that its merchandise is free of defects in material and workmanship for a period of twenty five (25) years from the date of invoice, provided that such merchandise is listed in U.S. Rubber Recycling's current price list at the time of the claim and such defects are not the result of ordinary wear and tear or an Act of God. U.S. Rubber Recycling's obligation under this warranty is limited to repair or replacement, at its option, and such repair or replacement shall be the only remedy. U.S. Rubber Recycling is not responsible for damage due to transportation, improper handling, alteration, abuse or negligence. U.S. Rubber Recycling shall not be

liable for any incidental or consequential damages including, but not limited to, any expenses associated with the removal or installation of any defective merchandise covered by this warranty. With respect to flooring and underlayment, U.S. Rubber Recycling's warranty is null and void if product is (i) stored for more than forty five (45) days or (ii) stored or installed in an environment where temperature and humidity are not controlled 24|7|365. U.S. Rubber Recycling makes no implied warranty of merchantability or fitness for any particular purpose. ALL OTHER WARRANTIES, EXPRESS OR IMPLIED, ARE EXCLUDED.



# Roll Dimensions

## Thickness Chart

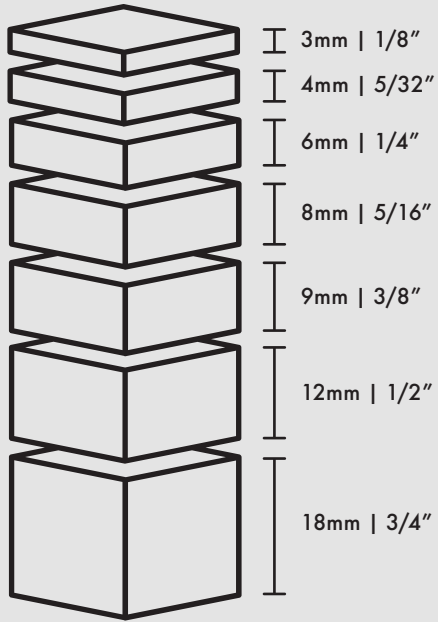

Thicknesses	Lengths*
3mm   1/8"	75'
4mm   5/32"	75'
6mm   1/4"	75'
8mm   5/16"	50'
9mm   3/8"	50'
12mm   1/2"	50'
18mm   3/4"	15'

\*Custom Lengths are always available



# Tile Dimensions

## Thickness Chart

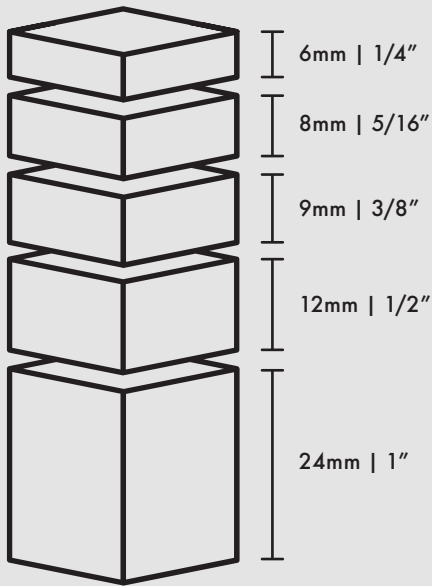

## Thicknesses

### Interlocking & Square Tile

- 6mm | 1/4"
- 8mm | 5/16"
- 9mm | 3/8"
- 12mm | 1/2"

### Eco-Lock Tile

- 6mm | 1/4"
- 8mm | 5/16"

### MEGA Tile

- 24mm | 1"

## Sizes/Styles

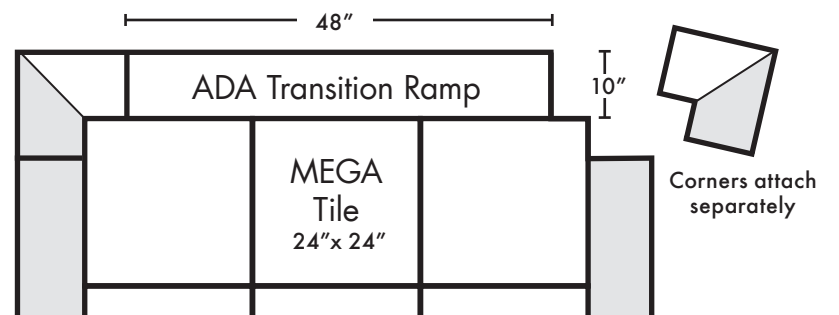
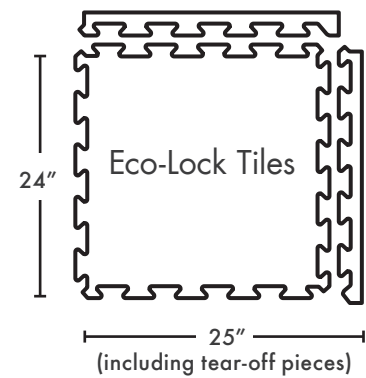
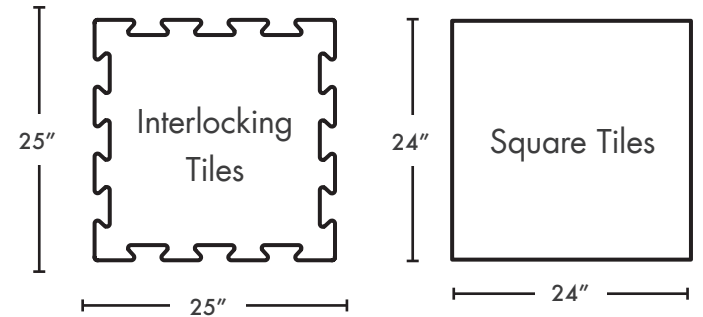

Interlocking Tile

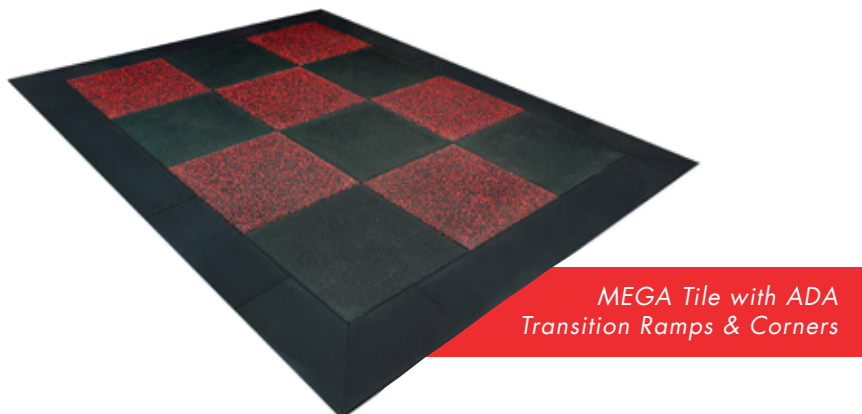

Eco-Lock Tile

Contact [info@usrubber.com](mailto:info@usrubber.com) for assistance specifying MEGA Tile