

# ***SPIRIT***

---

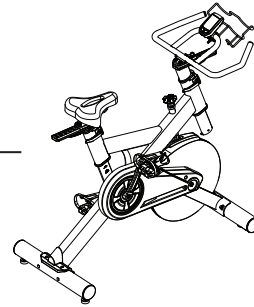

**XIC600** Indoor Cycle  
OWNER'S MANUAL



# TABLE OF CONTENTS

5	IMPORTANT SAFETY INSTRUCTIONS
6	IMPORTANT OPERATION INSTRUCTIONS
7	PRODUCT REGISTRATION
8	XIC600 ASSEMBLY INSTRUCTIONS
15	BIKE ADJUSTMENTS
18	CONSOLE OPERATION
20	FEATURES
24	TROUBLESHOOTING
25	GENERAL MAINTENANCE
26	MANUFACTURER'S LIMITED WARRANTY

*Thank you for purchasing our product, please save these instructions. Please do not perform or attempt any customizing, adjustments, repair or maintenance that is not described in this manual.*

# ***SPIRIT***

Congratulations on your new Indoor Cycle and welcome to the Spirit Fitness family!

Thank you for your purchase of this quality Indoor Cycle from Spirit Fitness. Your new Indoor Cycle was manufactured by one of the leading fitness manufacturers in the world and is backed by one of the most comprehensive warranties available. Through your dealer, Spirit Fitness will do all we can to make your ownership experience as pleasant as possible for many years to come. If not purchased direct from Spirit Fitness, the local dealership where you purchased this Indoor Bike is your administrator for all Spirit Fitness warranty and service needs. Their responsibility is to provide you with the technical knowledge and service personnel to make your experience more informed and any difficulties easier to remedy.

Please take a moment at this time to record the name of the dealer, their telephone number, and the date of purchase below to make any future, needed contact easy. We appreciate your support and we will always remember that you are the reason that we are in business.

Yours in Health,  
Spirit Fitness

NAME OF DEALER \_\_\_\_\_

DEALER PHONE # \_\_\_\_\_

PURCHASE DATE \_\_\_\_\_

## Important Safety Instructions

### WARNING

Read all instructions before using this appliance.

**WARNING** - To reduce the risk of injury to persons, install the Indoor Bike on a flat level surface.

- Use this equipment only for its intended use as described in this manual. Do not attempt to ride this bike at high pedal speeds until you have ridden the bike for some time and are comfortable riding at slower pedal speeds.
- In a home setting, keep children away from the bike when it is not in use. Keep children and pets away from the unit while it is in use.
- Keep hands away from all moving parts.
- The bike is NOT equipped with a freewheel system which means that when the flywheel is in motion, the pedals will be in motion. Do not attempt to stop the unit by applying backward pressure to pedals while they are turning as knee injury may occur. Do not attempt to remove your feet from pedals while they are moving.
- Wait for flywheel to coast to a stop before dismounting the bike. If you want to stop the flywheel, push down on the brake knob.
- Serious injury or death may occur from over-training. Consult a medical doctor or qualified fitness instructor to determine an exercise program appropriate for your level of fitness.
- Do not attempt to turn the pedal cranks by hand. Do

not touch any driving mechanism while it is in motion as possible injury could occur:

- Do not attempt to perform dip movements on handlebars
- Never drop or insert any object into any openings.
- Follow instructions for safe use of the equipment including proper seat position, handlebar position, and use of foot positioning system of pedals. Do not attempt to pull up handlebar post and seat post over the 'MAX.' graduation.
- For safe operation, allow for at least 1 foot (30cm) of free space to either side of the unit and 2 feet (60cm) of free space to the rear of the unit.
- Do not attempt to use your Indoor Cycle for any purpose other than for the purpose it is intended.
- Use of a chest strap transmitter (sold separately) is an accurate method of heart rate analysis. Various factors, including the user's movement, may affect the accuracy of heart rate readings.
- Wear proper shoes. High heels, dress shoes, sandals or bare feet are not suitable for use on your Indoor Bike. Quality athletic shoes are recommended to avoid leg fatigue.
- This exercise equipment is not intended for use by persons with reduced physical, sensory or mental capabilities, or lack of experience and knowledge.
- Keep children under the age of 13 away from this machine.

**SAVE THESE INSTRUCTIONS - THINK SAFETY!**

## Important Operation Instructions

### **WARNING**

**AS THE OWNER OF THIS EXERCISE EQUIPMENT, YOU SHOULD INSIST THAT ALL USERS FOLLOW THE SAME GUIDELINES: YOU SHOULD MAKE THIS MANUAL AVAILABLE TO ALL USERS.**

1. Obtain a complete physical examination from your medical doctor and enlist a health/fitness professional's aid in developing an exercise program suitable for your current health status.
2. When working out for the first time, start out slowly for a minimum of five minutes. After your muscles are warmed up, gradually increase the pedaling rate.
3. The speed and duration of your exercise program should always be subject to how you feel. Never permit peer pressure to exceed your personal judgment while exercising.
4. Overweight or severely de-conditioned individuals should be particularly cautious when using the equipment for the first time. Even though such individuals may not have histories of serious physical problems, they may perceive the exercise to be far less

intense than it really is, resulting in the possibility of overexertion or injury.

5. Proper installation and regular maintenance are required to ensure user's safety. Maintenance is the sole responsibility of the owner.
6. Weight Limit: 300 lbs.

**WARNING:** This product can expose you to chemicals including Toluene and Acrylamide which are known to the State of California to cause cancer and birth defects or other reproductive harm.

For more information go to [www.P65Warnings.ca.gov](http://www.P65Warnings.ca.gov)

# Important Operation Instructions

- **NEVER** operate this Indoor Cycle without reading and completely understanding the owner's manual.
- Use caution while participating in other activities while pedaling on your Indoor Cycle; such as watching television, reading, etc. These distractions may cause you to lose balance which may result in serious injury.
- Do not use excessive pressure on console control keys. They are precision set to function properly with little finger pressure.

## Record Your Serial Number

Please record the serial number of this fitness product in the space provided below.

Serial Number:

## Register Your Purchase

The self-addressed product registration card must be completed in full and returned to Spirit Fitness. You can also go to <https://www.spiritfitness.com> under the Support tab to register online.

Serial Number Location

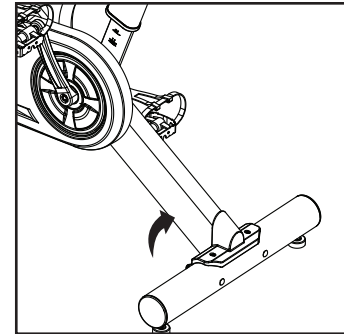

# XIC600 PRE ASSEMBLY

---

## UNPACKING

1. Cut the straps, then lift the box over the unit and unpack.
2. Carefully remove all parts from the carton and inspect for any damage or missing parts. If parts are damaged or missing, contact your dealer immediately.
3. Locate the hardware package. Remove the tools first. Remove the hardware for each step as needed to avoid confusion. The numbers in the instructions that are in parenthesis (#) are the item number from the assembly drawing for reference.

## TOOLS INCLUDED:

- ❑ 14/15mm Wrench (#85)
- ❑ Combination Allen Wrench & Phillips Head Screw Driver (#86)

## PARTS INCLUDED:

- ❑ 1 Main Frame
- ❑ 1 Flywheel
- ❑ 1 Front Stabilizer
- ❑ 1 Rear Stabilizer
- ❑ 1 Console Mast
- ❑ 1 Console
- ❑ 2 Foot Pedals
- ❑ 1 Water Bottle Rack
- ❑ 1 Hardware Kit



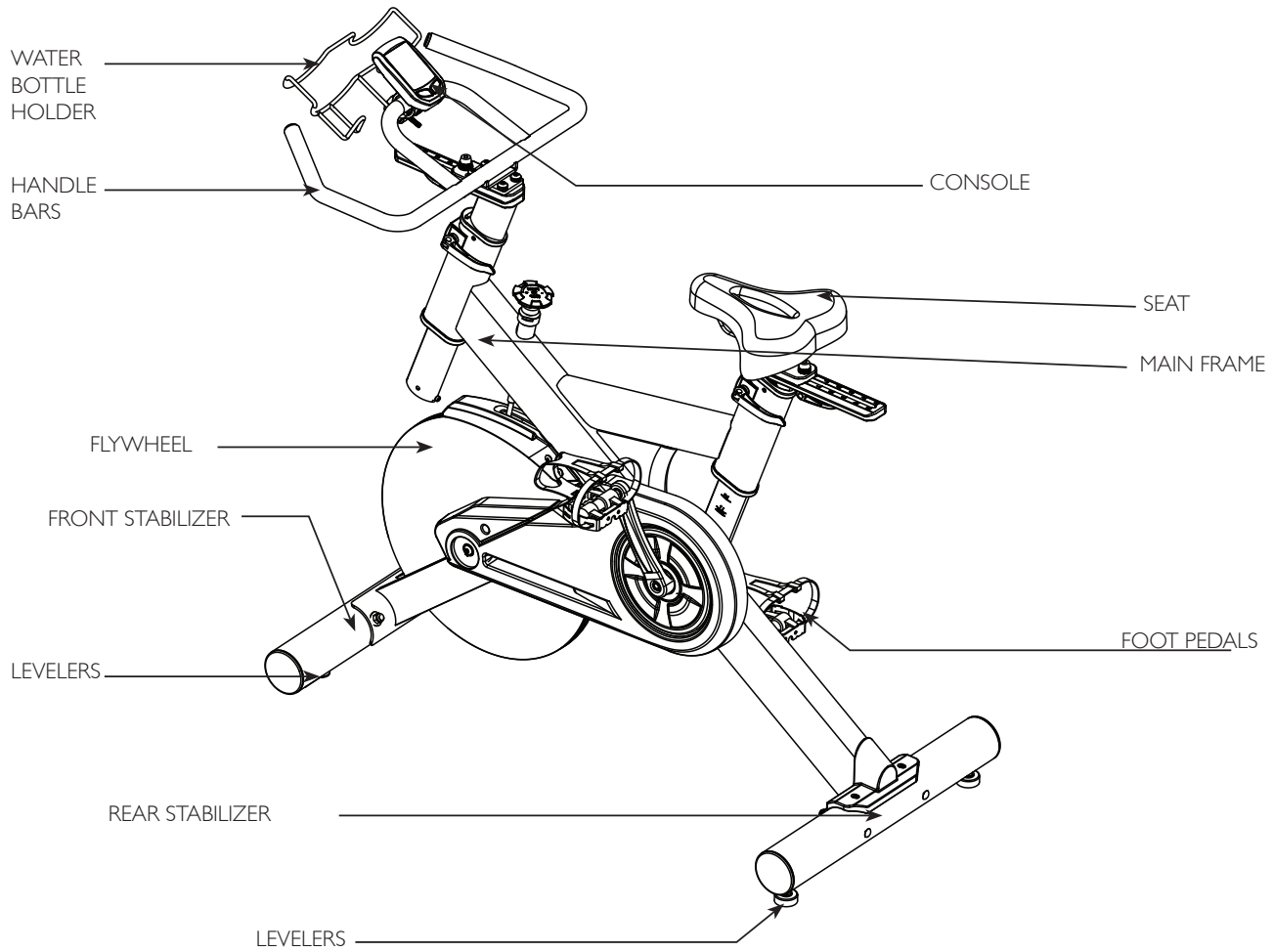

# XIC600 STEP ONE

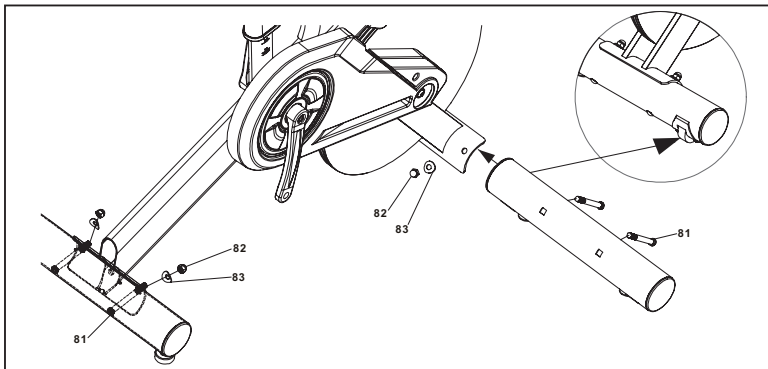

HARDWARE FOR STEP 1			
PART	TYPE	DESCRIPTION	QTY
81	CARRIAGE BOLTS	3/8"X3-1/2"	4
83	CURVED WASHERS	3/8"	4
82	CAP NUT	3/8"	4

1. Gather **HARDWARE FOR STEP 1**.
2. Install the **FRONT AND REAR STABILIZERS** with four **CARRIAGE BOLTS (81)**, four **CURVED WASHERS (83)** and four **CAP NUTS (82)**. The front and rear stabilizer are different. Be sure to assemble the stabilizer with the wheels onto the front of the bike.

# XIC600 STEP TWO

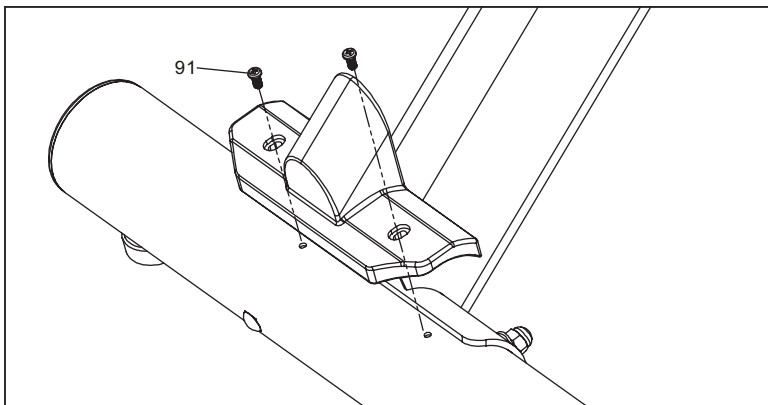

HARDWARE FOR STEP 2			
PART	TYPE	DESCRIPTION	QTY
91	SCREWS	M5X10mm	2

1. Gather **HARDWARE FOR STEP 2**.
2. Install the **REAR STABILIZER COVER** with two **SCREWS (91)**.

# XIC600 STEP THREE

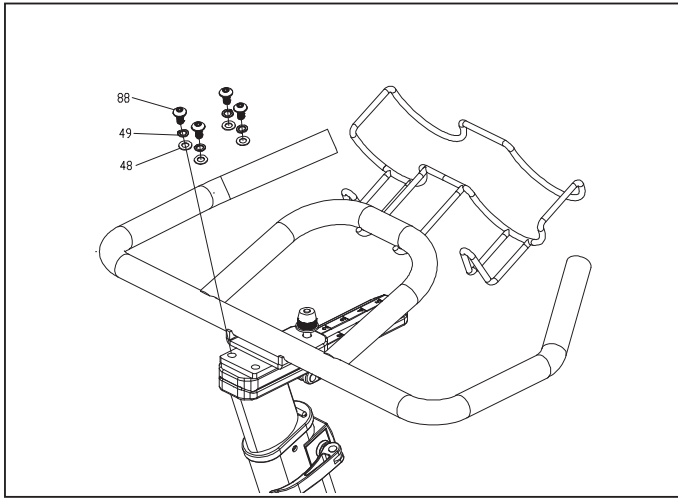

## HARDWARE FOR STEP 3

PART	TYPE	DESCRIPTION	QTY
88	BOLT	5/16"X15mm	4
49	SPLIT WASHERS	5/16"	4
48	FLAT WASHERS	5/16"	4

1. Gather **HARDWARE FOR STEP 3**.
2. Install the handlebars with four **BOLTS (88)**, **SPLIT WASHERS (49)** and four **FLAT WASHERS (48)**. Tighten the bolts securely.
3. Install the **BOTTLE HOLDER** to the handlebars by loosening the thumb screw, clamp to the handlebars and re-tightening the thumb screw.

# XIC600 STEP FOUR

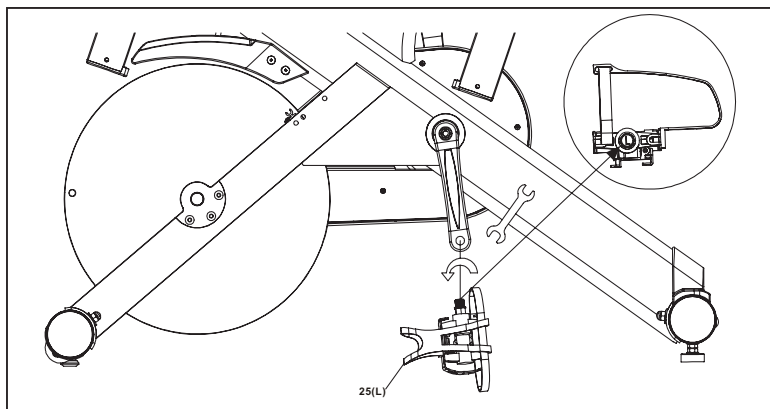
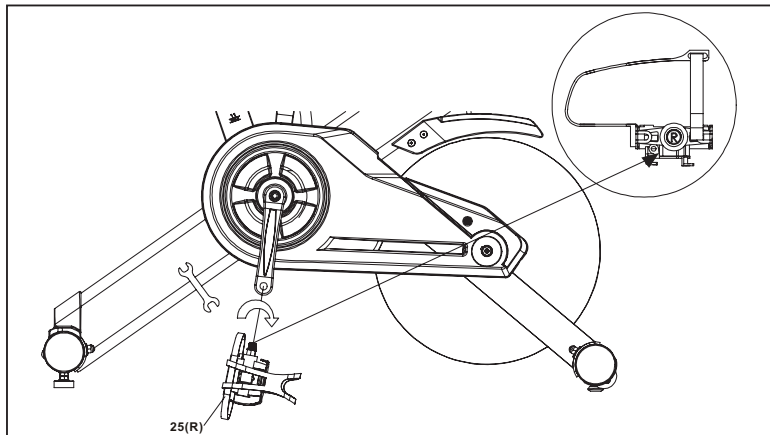

1. Install the **LEFT (25L)** and **Right (25R)** pedals to the crank arms.  
Please note that the Left pedal has a reverse threaded bolt and needs to be tightened in a counterclockwise direction. The pedals are identified by either an R or L stamped into the end of the bolt.

# XIC600 STEP FIVE

## Cycling Console Battery Installation:

1. Remove the battery cover from the back of the computer.
2. Insert 2 AAA batteries into the battery compartment and reinstall the battery cover.
3. When Battery working voltage is too low, The "Low battery" indicator will show up on the console display indicating it is time to change the batteries.

## Speed Sensor Transmitter Battery Installation

1. Remove the battery cover from the transmitter.
2. Install 2 AAA batteries in the battery compartment and reinstall the battery cover.
3. When new batteries are installed in the transmitter or console you must perform the synchronizing procedure below for the console to work properly

## Synchronizing the transmitter to the console:

1. After installing the batteries, and before attaching the console and transmitter to the bike, you must synchronize the two so they can "talk" to each other.
2. Press and hold the two keys on the front of the console for about 3 seconds until the display shows ID - -
3. Now press and hold the blue button on the transmitter for 3 seconds and release. The console display should show ID 0. NOTE: You must press the blue button within 10 seconds after the console is showing ID - - otherwise the console will show: ID ER. If the console shows this error then restart the procedure again.

4. It may be necessary to remove and re-install the batteries in both the console and transmitter if you continue to receive an error;

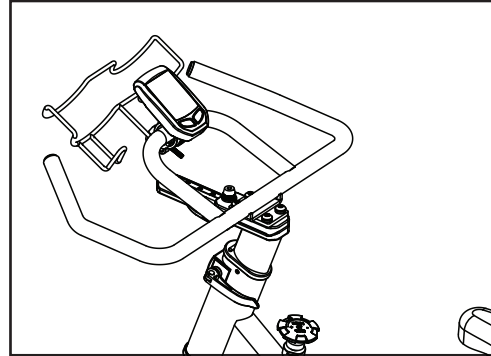

## Installation of the cycling monitor Console Installation:

1. Install the mounting clamp (2) to the back of the console (1) with the clamp mounting screw (3).
2. Install and slightly tighten the thumb screw (4) then adjust the console angle for optimal visibility. Once the console is adjusted, continue to tighten the screw until it is securely attached to the handle bar.

# XIC600 STEP FIVE

## Installing the speed transmitter:

1. Plug the speed sensor wire into the transmitter (6) and then attach the transmitter (with Velcro pre-attached to the back) to the Velcro half that is pre-installed to the bike frame. The Velcro is mounted to the back side of the chain cover, below the left crank.

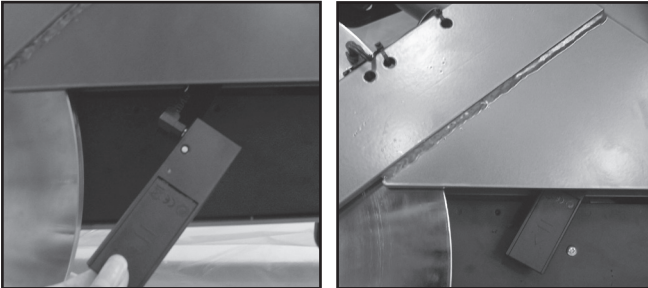

# XIC600 ADJUSTING BIKE

Take some time to learn how to properly adjust the bike to your body; it will make your workouts more pleasant and a safer experience too. Riding the bike when it is incorrectly adjusted can result in discomfort and increase your risk of injury.

## Adjustment of Seat Position

### Seat Height Adjustment

1. Standing next to the bike, adjust seat until it is about hip height.
2. Rotate crank arms until the pedals are in the vertical position: 12 and 6 o'clock.
3. Place your foot in toe cage of pedal closest to the floor and mount the bike. Ensure that the ball of your foot is over the center of pedal. Your leg should be slightly bent at the knee, about 5 degrees.
4. If your leg is too straight or your foot cannot touch pedal you will need to lower seat height. If your leg is bent too much you will need to raise seat height.
5. Dismount the bike. Loosen the quick release lever on seat post and adjust up or down as necessary.
6. When seat is in the desired position, tighten the quick release to secure the seat post.
7. Note the final position mark on the seat post for future reference. Seat height can change when wearing different shoes, always wear shoes when cycling.

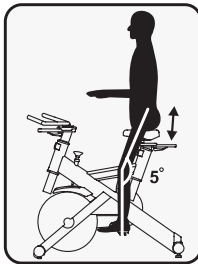

## Adjustment of Seat Position

### Seat Forward /Aft Adjustment

1. Sit on bike with crank arms in the 3 and 9 o'clock positions. For road bike training, a proper forward/aft position of the seat is achieved when small bump at the top of the shin is above pedal axle.
2. Dismount the bike. Loosen the quick release under the seat and slide the seat forward or backward as desired; then tighten the quick release.

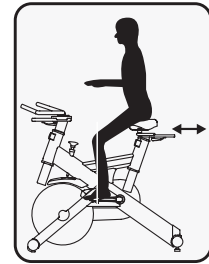

# XIC600 ADJUSTING BIKE

## Handlebar Adjustment

### Handlebar Height Adjustment

1. The Handlebar height is a matter of preference. Start with a handlebar height that is the same as the seat's height. Adjusting the handlebar higher will give the rider a more upright position; lower will result in a more crouched position.
2. Raise or lower the handlebar by loosening quick release on handlebar post and adjust by sliding the handlebar mount up or down as desired. Then tighten the quick release to secure the handlebar post. Note the final position mark on handlebar post for future reference.

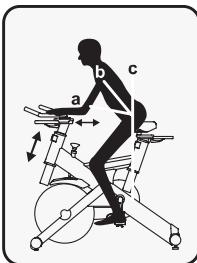

### Adjustment of Handlebar's Forward/Aft Position

1. Loosen the quick release under the handlebar and slide the handlebar forward or backward as desired. Suitable forward/aft position should allow the rider to comfortably grasp the handlebar with a slight bend at the elbow.
2. Tighten the quick release to secure the handlebar assembly.

## Adjusting the Pedal Straps

1. Place your feet in between the aluminum surface of the pedal and the nylon foot strap that wraps around it. If the opening is too narrow, depress the spring loaded clasp with one hand and pull on the nylon strap with the other to increase the opening area. If it is too loose or to tighten the strap, depress the spring loaded clasp, then pull on the open end of the nylon strap until the strap is snug around each foot.

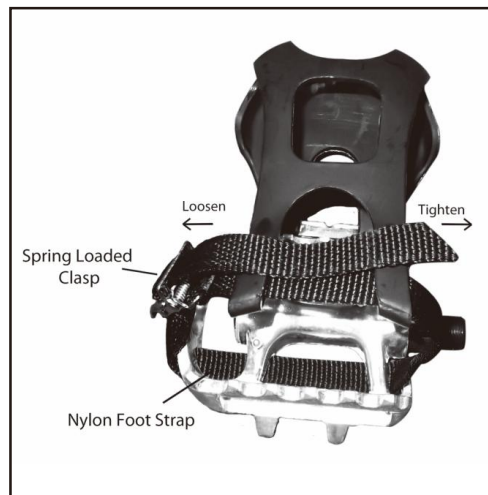



# XIC600 BASIC OPERATION

---

Now that you have established a proper riding position, take a few minutes to ride the bike and determine that your position is comfortable. Start pedaling at a slow pace with your toes and knees pointed directly forward. Hold the handlebar lightly and in a position that allows your shoulders and upper body to relax. Pedal easily, at a low resistance until you feel confident that you could ride in that position for the duration of your workout.

## **WARNING!**

***IF AT ANY TIME DURING YOUR WORKOUT, YOU FEEL CHEST PAIN, EXPERIENCE SEVERE MUSCULAR DISCOMFORT, FEEL FAINT, OR ARE SHORT OF BREATH, STOP EXERCISING AT ONCE. IF THE CONDITION PERSISTS, YOU SHOULD CONSULT YOUR MEDICAL DOCTOR IMMEDIATELY.***

1. Pedaling resistance is controlled by the tension knob. Resistance can be changed at any time by turning tension knob: clock-wise for more resistance; counterclockwise for less resistance.
2. To apply the brake, press down on the tension knob.
3. Before dismounting, apply the brake to stop flywheel, or increase resistance and let flywheel come to a stop.
4. Always follow the safety guidelines to minimize risk of injury.

# XIC600 CONSOLE OPERATION

---

Large LCD  
Matrix Window

Built-in Heart  
Rate Receiver



Easy-Touch  
Control Buttons

# XIC600 CONSOLE OPERATION

---

## PLEASE NOTE:

1. The Cycling Monitor system is designed as sealed unit and not meant to be opened other than for the sole purpose of installing batteries. Any opened units will void the warranty.
2. To clean the Cycling Monitor use a clean damp cloth. Use of any caustic cleaning solutions will void the warranty.
3. The Cycling Monitor system is NOT waterproof, only water resistant. Any excessive exposure to water will void the warranty.

## CONSOLE SPECIFICATION

CADENCE BAR GRAPH: 0~200rpm/10rpm per Bar

RPM : 0 ~ 240 RPM

SPEED : 0 ~ 96 KM/H (0 ~ 60 mph)

PULSE : 30 ~ 240 BPM

Time : Count down range 1~99 Minutes

Count up range 00:01 ~99:59

## IMPORTANT SAFETY INSTRUCTIONS WARNING

BEFORE BEGINNING THIS OR ANY OTHER EXERCISE PROGRAM, CONSULT A PHYSICIAN. THE PHYSICIAN CAN HELP YOU BETTER DETERMINE WHAT ACTIVITIES OR PROGRAMS ARE MOST SUITED FOR YOU. IF AT ANY TIME DURING THE WORKOUT YOU FEEL FAINT, OR CHEST PAINS, OR SEVER SHORTNESS OF BREATH, STOP EXERCISING IMMEDIATELY AND CONSULT A PHYSICIAN.

The Cycling Console carton consists of a computer console, speed sensor transmitter. The transmitter counts the number of times the magnet, which is mounted on the crank assembly, passes the sensor. The speed sensor transmitter will then send a coded signal to the console which contains the measured value (Speed and Cadence ).

Both the computer console and the speed sensor transmitter use AAA type batteries. Please install the supplied AAA batteries in the computer console and speed sensor transmitter before using.

# XIC600 FEATURES

## DISPLAY WINDOW

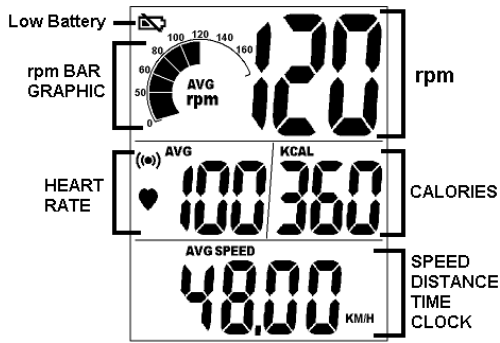

## TIME

Time is measured in min:sec

There is a time of day clock and a workout timer clock. The workout time will count up or count down during pedaling. If pedaling stops, the time will stop counting after 3sec.

## RPM/CADENCE

Cadence is the measurement of how fast the cranks are rotating in RPM. The approximate speed of the bike can also be display in MPH or KPH. In addition to the MPH/KPH, the RPM section of the display also has a bar graph that allows the rider to visually keep track of the approximate RPM.

## DISTANCE

Distance is the measurement of the virtual distance traveled on the bike. This distance is based on the user riding a bike with tires that are the same size as the group bike's flywheel.

## KCAL

Kcal is the approximation of calories burned during your work out. The calories are an estimate only.

## HEART RATE

This the approximation of heart rate detected from the chest belt during your work out. (Heart-Rate Strap sold separately.)

## QUICK Start

When the console is in Power Saving Mode, hold down any key to wake up the console and go to the start-up screen, also called "QUICK START" active state.

## Power Saving Mode

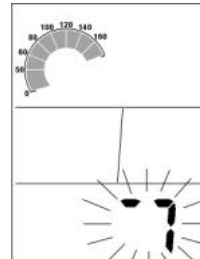

## QUICK START Mode

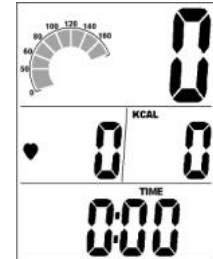

# XIC600 FEATURES

## MODE SELECT

Press the left hand key to select the **SPEED, DIST, TIME, or CLOCK** at the bottom of the display.

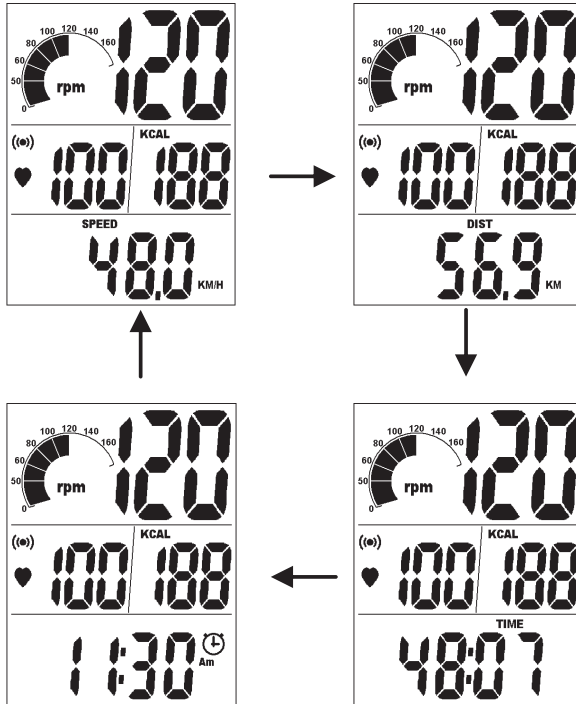

## RESET/HEART RATE ALARM SELECT

Press the right hand key to activate the heart rate alarm. If the alarm is on, the alarm icon will flash and a beep will sound to indicate that your heart rate is either above or below the selected target zone.



**RESET:** Press and hold the right hand key for 3 seconds. All the accumulated values for AVG SPEED, AVG PULSE, TIME, DIST, KCAL will return to zero.

## TIME OF DAY

1. If you want to change the time of day settings at any time press the left hand key until time of day is displayed then press the right hand key for 3 seconds. The display will flash an indication of whether the clock is set for 12H clock or 24H military time clock. Press the right hand key to change.

# XIC600 FEATURES

2. Press the left hand key to switch to the hour setting, use the right hand key to change hours.
3. Press the left hand key again to switch to minutes and use the right hand key to change the minutes.
4. When you are finished, wait a few seconds for the display to return to the start-up screen.

## Setting Workout Time

Press and hold the right hand key when the bottom section of the display is showing SPEED; the Minutes will now be flashing. Press the right hand key to increase Minutes setting.

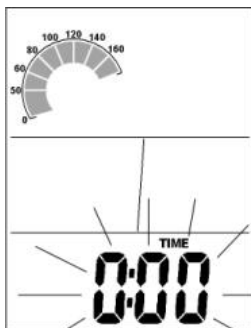

2. To clear the exercise Time press the left hand key until the time is displayed then hold the right hand key for three seconds.

## HEART RATE TARGET ZONES

Press the left hand key until "SPEED" is displayed then hold the right hand key for 3 seconds. The TIME will be flashing; press the left hand key to select the heart rate target zone settings.

Press the right hand key to increase maximum heart rate limit. After setting the maximum heart rate, press the left hand key to adjust the minimum heart rate limit.

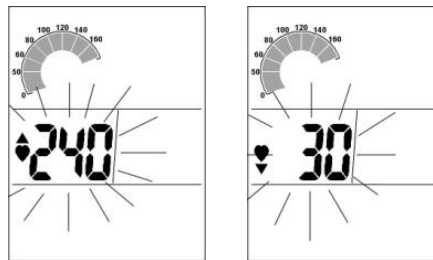

## PERSONAL DATA SETTING

1. GENDER: Press the left hand key until SPEED is displayed then, press the right hand key for 3 seconds. The TIME will be flashing, press the left hand key until the gender icon is blinking. Press the right hand key to select the gender

# XIC600 FEATURES

---

2. Press the left hand key to set the measuring value for weight (Lb or Kg), press the right hand key to select.

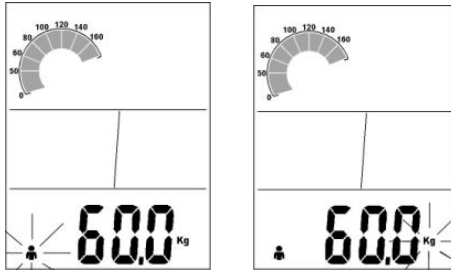

3. BODYWEIGHT: Press the left hand key to set the bodyweight, press the right hand key to increase the weight. Press and hold the right hand key for rapid advance.

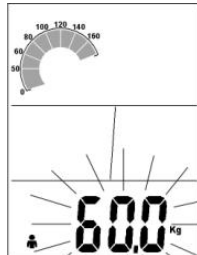

# TROUBLESHOOTING

## **No Display on Console**

Hold down any key to bring the console to “Quick Start” mode.

Ensure that the batteries are installed properly in the console and transmitter. If they are, install fresh batteries.

## **No Heart Rate signal displayed**

Ensure that your chest strap (sold separately) is worn correctly and that there is moisture under the electrodes.

Relocate the bike away from any equipment that could potentially interrupt the radio frequency signal, such as a DVD player or television, etc.

## **Cadence number jumps high or low**

Separate bikes that may be set to the same console code and are cross-talking, or re-synchronize the transmitter and console (see page 5). Relocate the bike to a different part of the room, away from any RF interference areas.

## **Heart Rate signal gets interrupted or drops out**

Ensure that there is a minimum distance of 36 inches between bikes. Verify that your chest strap (sold separately) is secure and that the electrodes are making contact with your chest at all times.

### **CAUTION**

**EXTERNAL INTERFERENCE MAY BE CAUSED BY OTHER ELECTRONIC DEVICES, SUCH AS: NEARBY TELEVISIONS, STEREO EQUIPMENT, SPEAKERS, ELECTRICAL WIRE CABLING, ETC. IF YOU EXPERIENCE DISTURBANCES IN THE CONSOLE DISPLAY TRY MOVING YOUR BIKE(S) AWAY FROM POTENTIAL RF INTERFERENCE AREAS.**

## **Notice of FCC Compliance**

*This equipment has been tested and found to comply with the limits for a Class C Low Power Communication Device Transmitter, pursuant to Part 15 of the FCC rules. Operation is subject to the following conditions: (1) This device may not cause harmful interference, and (2) this device must accept any interference received, including interference that may cause undesired operation. There is no guarantee that interference will not occur in a particular installation. If this equipment experiences interference from a radio, television, or other RF signal, the user is encouraged to try and correct the interference by increasing the separation between the equipment and the apparatus emitting the interfering RF signal.*



# GENERAL MAINTENANCE

1. Do not service internal parts of pedals. If they are found to be worn internally, we recommend replacing the pedal.
2. Use of lubricants or cleaning solutions other than those specified will result in diminished performance and a shorter life span for that part.
3. Wipe down all areas in the sweat path with a damp cloth after each workout.
4. If a squeak, thump, clicking or rough feeling develops the main cause is most likely one of three reasons:
  - I. The hardware was not sufficiently tightened during assembly. All bolts that were installed during assembly need to be tightened as much as possible. It may be necessary to use a larger wrench than the one provided if you cannot tighten the bolts sufficiently. We cannot stress this point enough; 90% of calls to the service department for noise issues can be traced to loose hardware.
  - II. The crank arm nut needs to be retightened.
  - III. If squeaks or other noises persist, check that the unit is properly leveled. There are 2 leveling pads on the bottom of the rear stabilizer; use a 14mm wrench (or adjustable wrench) to adjust the levelers.

Part	Recommended Action	Frequency	Cleaner	Lubricant
Pedals	Ensure that pedals are tight in crank arms; that all screws on pedals are tight; and that the pedal straps are not frayed	Before each Use	N/A	N/A
Frame	Wipe down by using a soft damp clean cloth	Daily	Water	N/A
Flywheel	Wipe down by spraying on a rag and applying a light coat to sides of the flywheel	Weekly	WD-40 Spray	N/A
Brake Pad	Inspect for excessive wear or a dry leather brake pad	Weekly	N/A	3-IN-ONE Oil or 10W Oil. Do not use Silicone-based Lubricants

# Indoor Cycle Warranty - Effective August 22, 2018

Spirit Fitness, Inc. (Spirit Fitness) warrants all its Indoor Cycle parts for a period of time listed below from the date of retail sale, as determined by sale receipt, or in the absence of a sales receipt eighteen (18) months from the original factory shipping date. Spirit Fitness' responsibilities include providing new or remanufactured parts, at Spirit Fitness' option, and technical support to our independent dealers and servicing organizations. In the absence of a dealer or service organization, these warranties will be administered by Spirit Fitness directly to a consumer. The warranty period applies to the following components:

<b>Warranty</b>	<b>Frame</b>	<b>Parts</b>	<b>Labor</b>
<b>Residential</b>	<b>Lifetime</b>	<b>3 Years</b>	<b>1 Year</b>

## NORMAL RESPONSIBILITIES OF THE CONSUMER

This warranty applies only to products in ordinary household (see restrictions above), and the consumer/facility is responsible for the items listed below:

1. The warranty registration card must be completed and returned to the address listed on the card within 10 days of the original purchase to validate the manufacturer's limited warranty.
2. Proper use of the Indoor Bike in accordance with the instructions provided in this manual
3. Proper installation in accordance with instructions provided with the Indoor Bike and with all local electric codes.
4. Expenses for making the Indoor Bike accessible for servicing, including any item that was not part of the Indoor Bike at the time it was shipped from the factory.
5. Damages to the Indoor Bike finish during shipping, installation or following installation.
6. Routine maintenance of this unit as specified in this manual.

## EXCLUSIONS

This warranty does not cover the following:

1. CONSEQUENTIAL, COLLATERAL, OR INCIDENTAL DAMAGES SUCH AS PROPERTY DAMAGE AND INCIDENTAL EXPENSES RESULTING FROM ANY BREACH OF THIS WRITTEN OR ANY IMPLIED WARRANTY.  
Note: Some states do not allow the exclusion or limitation of incidental or consequential damages, so this limitation or exclusion may not apply to you.
2. Service call reimbursement to the consumer. Service call reimbursement to the dealer that does not involve malfunction or defects in workmanship or material, for units that are beyond the warranty period, for units that are beyond the service call reimbursement period, for Indoor Bike not requiring component replacement, or Indoor Bike not in ordinary household or light commercial use.
3. Damages caused by services performed by persons other than authorized Spirit Fitness service companies; use of parts other than original Spirit Fitness parts; or external causes such as corrosion, discoloration of paint or plastic, alterations, modifications, abuse, misuse, accident, improper maintenance, inadequate power supply, or acts of God.
4. Products with original serial numbers that have been removed or altered.
5. Products that have been: sold, transferred, bartered, or given to a third party.

6. Products that do not have a warranty registration card on file at Spirit Fitness. Spirit Fitness reserves the right to request proof of purchase if no warranty record exists for the product.
7. THIS WARRANTY IS EXPRESSLY IN LIEU OF ALL OTHER WARRANTIES EXPRESSED OR IMPLIED, INCLUDING THE WARRANTIES OF MERCHANTABILITY AND/OR FITNESS FOR A PARTICULAR PURPOSE.
8. Product use in any environment other than a residential setting or non-dues paying facility with 5 hours use or less per day.
9. Warranties outside of the United States may vary. Please contact your local dealer for details.

#### SERVICE

Keep your bill of sale. Twelve (12) months from the date on the bill of sale or eighteen (18) months from the date of factory shipping as determined by the serial number establishes the labor warranty period should service be required. If service is performed, it is in your best interest to obtain and keep all receipts. This written warranty gives you specific legal rights. You may also have other rights that vary from state to state. Service under this warranty must be obtained by following these steps, in order:

1. Contact your selling authorized Spirit Fitness dealer. OR
2. Contact your local authorized Spirit Fitness service organization.
3. If there is a question as to where to obtain service, contact our service department at (870) 935-1107.
4. Spirit Fitness' obligation under this warranty is limited to repairing or replacing, at Spirit Fitness' option, the product through one of our authorized service centers. All repairs must be preauthorized by Spirit Fitness. If the product is shipped to a service center freight charges to and from the service center will be the customer's responsibility. For replacement parts shipped while the product is under warranty, the customer will be responsible for shipping and handling charges. For in-home service, the customer will be responsible for a trip charge. There will be an additional trip charge if the customer is located over 100 miles from the nearest service center.
5. The owner is responsible for adequate packaging upon return to Spirit Fitness. Spirit Fitness is not responsible for damages in shipping. Make all freight damage claims with the appropriate freight carrier: DO NOT SHIP ANY UNIT TO OUR FACTORY WITHOUT A RETURN AUTHORIZATION NUMBER. All units arriving without a return authorization number will be refused.
6. For any further information, or to contact our service department by mail, send your correspondence to:

**Spirit Fitness, Inc.**  
**P.O. Box 2037**  
**Jonesboro, AR 72402-2037**

Product features or specifications as described or illustrated are subject to change without notice. All warranties are made by Spirit Fitness, Inc. This warranty applies only in the 48 contiguous United States. NOTE: This does not apply to Alaska or Hawaii.





800.258-8511  
spiritservice@spiritfitness.com  
www.spiritfitness.com



Spirit Fitness  
3000 Nestle Road  
Jonesboro, AR 72401

***SPIRIT***

XIC600 Owners Manual  
© 2018 All Rights Reserved  
Revision: 08.22.2018