

CT850ENT TREADMILL
OWNER'S MANUAL

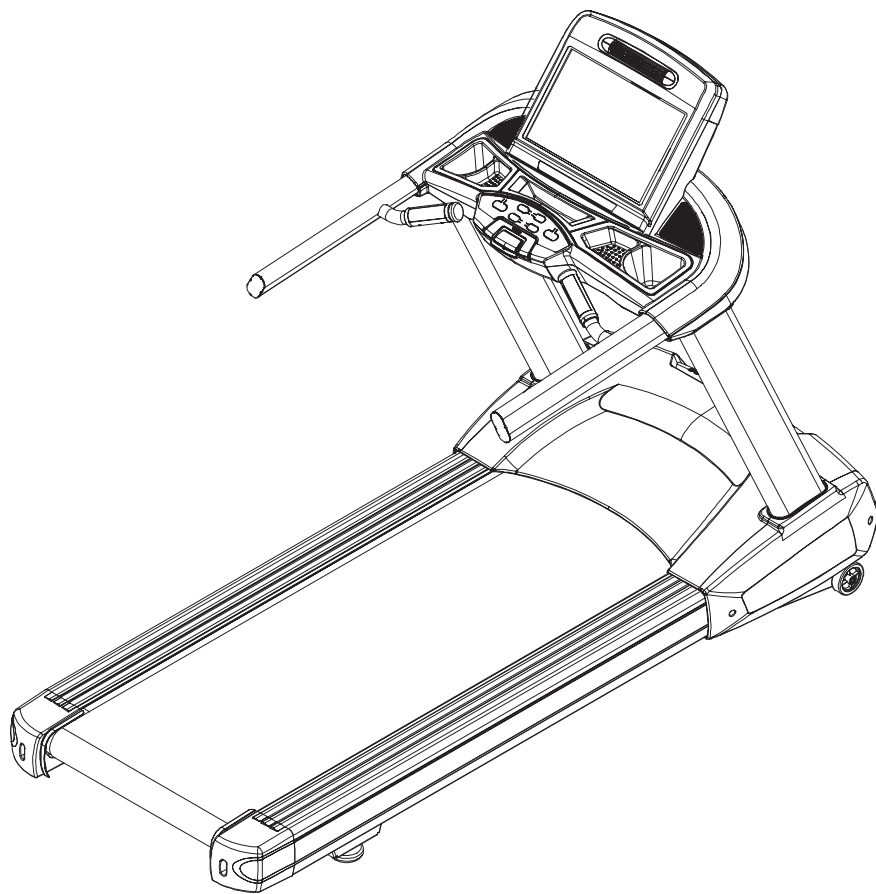

TABLE OF CONTENTS

3	IMPORTANT SAFETY INSTRUCTIONS
4	IMPORTANT ELECTRICAL INSTRUCTIONS
6	IMPORTANT OPERATION INSTRUCTIONS
7	PRODUCT REGISTRATION
8	CT850ENT ASSEMBLY INSTRUCTIONS
14	CONSOLE OPERATION
23	TOUCH SCREEN OPERATION
31	PROGRAMMABLE FEATURES
46	GENERAL MAINTENANCE
50	TROUBLESHOOTING
51	MANUFACTURER'S LIMITED WARRANTY

Thank you for purchasing our product, please save these instructions. Please do not perform or attempt any customizing, adjustments, repair or maintenance that is not described in this manual.



Congratulations on your new Treadmill and welcome to the Spirit Fitness family!

Thank you for your purchase of this quality Treadmill from Spirit Fitness. Your new Treadmill was manufactured by one of the leading fitness manufacturers in the world and is backed by one of the most comprehensive warranties available. Through your dealer, Spirit Fitness will do all we can to make your ownership experience as pleasant as possible for many years to come. If not purchased direct from Spirit Fitness, the local dealership where you purchased this Treadmill is your administrator for all Spirit Fitness warranty and service needs. Their responsibility is to provide you with the technical knowledge and service personnel to make your experience more informed and any difficulties easier to remedy.

Please take a moment at this time to record the name of the dealer, their telephone number, and the date of purchase below to make any future, needed contact easy. We appreciate your support and we will always remember that you are the reason that we are in business.

Yours in Health,
Spirit Fitness

NAME OF DEALER _____

DEALER PHONE # _____

PURCHASE DATE _____

IMPORTANT SAFETY INSTRUCTIONS

WARNING

When using an electrical appliance, basic precautions should always be followed, including the following:

Read all instructions before using this appliance.

DANGER - To reduce the risk of electric shock:

Always unplug this appliance from the electrical outlet immediately after using and before cleaning.

WARNING - To reduce the risk of burns, fire electric shock, or injury to persons:

- An appliance should never be left unattended when plugged in. Unplug from outlet when not in use, and before putting on or taking off parts.
- Do not operate under blanket or pillow. Excessive heating can occur and cause fire, electric shock, or injury to persons.
- Close supervision is necessary when this appliance is used by, on, or near children, invalids, or disabled persons.
- Use this appliance only for its intended use as described in this manual. Do not use attachments not recommended by the manufacturer.
- Never operate this appliance if it has a damaged cord or plug, if it is not working properly, if it has been dropped or damaged, or dropped into water. Return the appliance to a service center for examination and repair.
- Do not carry this appliance by supply cord or use cord as a handle.
- Keep the cord away from heated surfaces.
- Never operate the appliance with the air openings blocked. Keep the air openings free of lint, hair, and the like.
- Never drop or insert any object into any opening.
- Do not use outdoors.
- Do not operate where aerosol (spray) products are being used or where oxygen is being administered.
- Connect this appliance to a properly grounded outlet only. See Grounding Instructions.
- The appliance is intended for household use.
- Maximum User Weight: 450 lbs
- This appliance is not intended for use by persons with reduced physical, sensory or mental capabilities, or lack of experience and knowledge, unless they have been given supervision or instruction concerning use of the appliance by a person responsible for their safety.

- Keep children under the age of 13 away from this machine.
- ASTM F2115-05 Specifications 6.1.2.11 The recommended minimum clearance required around each treadmill for access to, passage around, and emergency dismount shall be stated. The minimum dimensions are to be: 0.5 m (19.7 in.) on each side of the treadmill, and 1 m (39 in.) behind the machine.

SAVE THESE INSTRUCTIONS - THINK SAFETY!

IMPORTANT ELECTRICAL INSTRUCTIONS

WARNING

NEVER use a ground fault circuit interrupt (GFCI) wall outlet with this treadmill. As with any appliance with a large motor, the GFCI will trip often. Route the power cord away from any moving part of the treadmill including the elevation mechanism and transport wheels.

NEVER remove any cover without first disconnecting AC power. If voltage varies by ten percent (10%)

or more, the performance of your treadmill may be affected. Such conditions are not covered under your warranty. If you suspect the voltage is low, contact your local power company or a licensed electrician for proper testing.

NEVER expose this treadmill to rain or moisture. This product is NOT designed for use outdoors, near a pool or spa, or in any other high humidity environment. The operating temperature specification is 40 to 120 degrees Fahrenheit, and humidity is 95% non-condensing (no water drops forming on surfaces).

Circuit Breakers: Some circuit breakers used in homes are not rated for high inrush currents that can occur when a treadmill is first turned on or even during use. If your treadmill is tripping the house circuit breaker (even though it is the proper current rating) but the circuit breaker on the treadmill itself does not trip, you will need to replace the home breaker with a high inrush type. This is not a warranty defect. This is a condition we as a manufacturer have no ability to control. This part is available through most electrical supply stores.

Examples: Grainger part # 1D237, or available online at www.squared.com part #QO120HM. The electrical outlet used should have a dedicated 15 amp circuit breaker.

GROUNDING INSTRUCTIONS

This product must be grounded. If the treadmill should malfunction or breakdown, grounding provides a path of least resistance for electric current, reducing the risk of electric shock. This product is equipped with a cord having an equipment-grounding plug. The plug must be plugged into an appropriate outlet that is properly installed and grounded in accordance with all local codes and ordinances.

DANGER - Improper connection of the equipment-grounding conductor can result in a risk of electric shock. Check with a qualified electrician or serviceman if you are in doubt as to whether the product is properly grounded. Do not modify the plug provided with the product if it will not fit the outlet; have a proper outlet installed by a qualified electrician.

This product is for use on a nominal 110-volt/15 amp dedicated circuit, and has a grounding plug that looks like the plug illustrated below. A temporary adapter that looks like the adapter illustrated below may be used to connect this plug to a 2-pole receptacle as shown below if a properly grounded outlet is not available. The temporary adapter should be used only until a properly grounded outlet, (shown below) can be installed by a qualified electrician. The green colored rigid ear-lug, or the like, extending from the adapter, must be connected to a permanent ground such as a properly grounded outlet box cover. Whenever the adapter is used, it must be held in place by a metal screw.

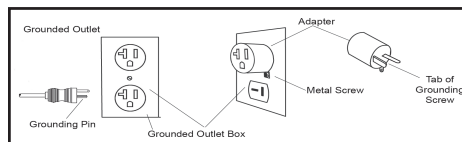

IMPORTANT OPERATION INSTRUCTIONS

- NEVER operate this Treadmill without reading and completely understanding the results of any operational change you request from the computer.
- Understand that changes in speed or incline do not occur immediately. Set your desired speed or incline level on the computer console and release the adjustment button. The computer will obey the command gradually.
- Use caution while participating in other activities while on your Treadmill; such as watching television, reading, etc. These distractions may cause you to lose balance which may result in serious injury.
- Do not use excessive pressure on console control buttons. They are precision set to function properly with little finger pressure.

WARNING

This product can expose you to chemicals including Toluene and Acrylamide which are known to the State of California to cause Cancer and birth defects or other reproductive harm. For more information, go to www.P65Warnings.ca.gov

RECORD YOUR SERIAL NUMBER

Please record the serial number of this fitness product in the space provided below.

Serial Number:

Serial Number Location

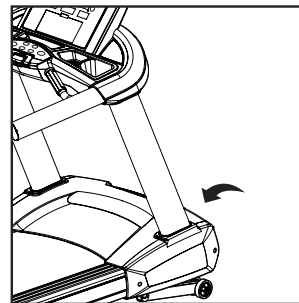

REGISTER YOUR PURCHASE

The self-addressed product registration card must be completed in full and returned to Spirit Fitness. You can also go to <http://www.spiritfitness.com/commercialwarrantyregistration.html> under the Support tab to register online.

CT850ENT PRE-ASSEMBLY

UNPACKING

1. Cut the straps, then along the dotted line on the bottom of the box; lift the box over the unit and unpack.
2. Locate the hardware package. The hardware is separated into four steps. Remove the tools first. Remove the hardware for each step as needed to avoid confusion. The numbers in the instructions that are in parenthesis (#) are the item number from the assembly drawing for reference.

TOOLS INCLUDED:

- 3/8" Allen Wrench
- 10mm Allen Wrench
- Phillips Screwdriver

PARTS INCLUDED:

- 2 Console Masts
- 2 Side Covers
- 1 Base Frame
- 1 Console Support
- 1 Console
- 1 Safety Button
- 1 Power Cord
- 1 Tube of Lubricant
(1 application)
- 1 Hardware Kit

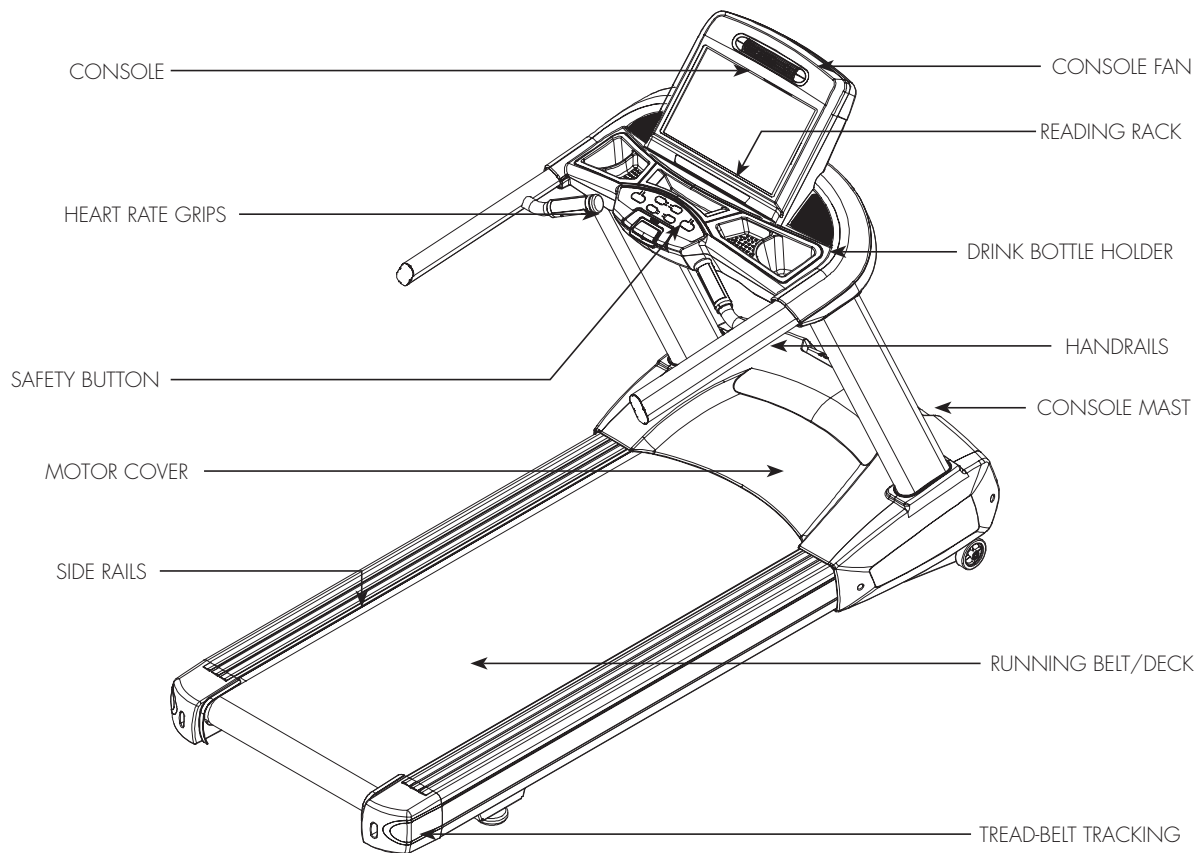

CT850ENT STEP ONE

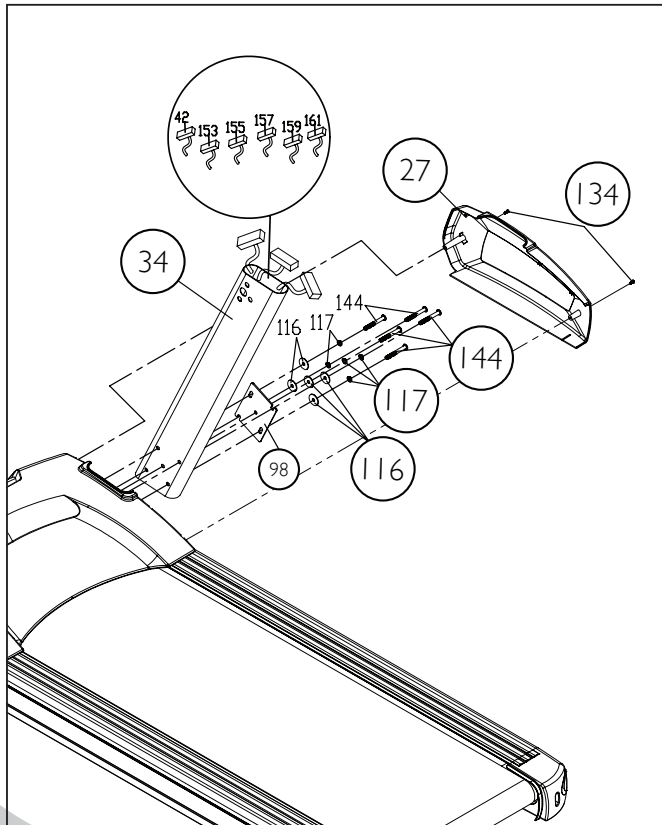

HARDWARE FOR STEP 1

PART	TYPE	DESCRIPTION	QTY
116	FLAT WASHER	3/8"X35X2T	10
117	SPLIT WASHER	3/8"X16.5X2.0T	10
134	SCREW	M5X12MM	4
144	BOLT	3/8"X3"	10

1. The **RIGHT UPRIGHT (34)** has a preinstalled Lower **COMPUTER CABLE (42)**, **TV SIGNAL (153)**, **CONSOLE POWER (155)**, **NETWORK (157)**, **CSAFE (159)**, and **HDMI CABLE (161)**. To install the uprights on the base frame, special care must be taken not to pinch the computer cable between the upright and frame base. Slide the **SPLIT WASHER (117)** and **FLAT WASHER (116)** on the **BUTTON HEAD SOCKET BOLT (144)**. Slide the **BOLT** through the top hole in the **RETAINING PLATE (98)**, and corresponding top hole in the upright tube, and screw into the base frame. Now install the other 4 **BUTTON HEAD SOCKET BOLTS (144)** together with **SPLIT WASHERS (117)**, and **FLAT WASHERS (116)** and tighten all 5 bolts up.
2. Repeat this step to install the **LEFT UPRIGHT (33)**.
3. Attach the **LEFT and RIGHT PLASTIC COVERS (26-L, 27-R)** with 4 **PHILLIPS HEAD SCREWS (134)**.

CT850ENT STEP TWO

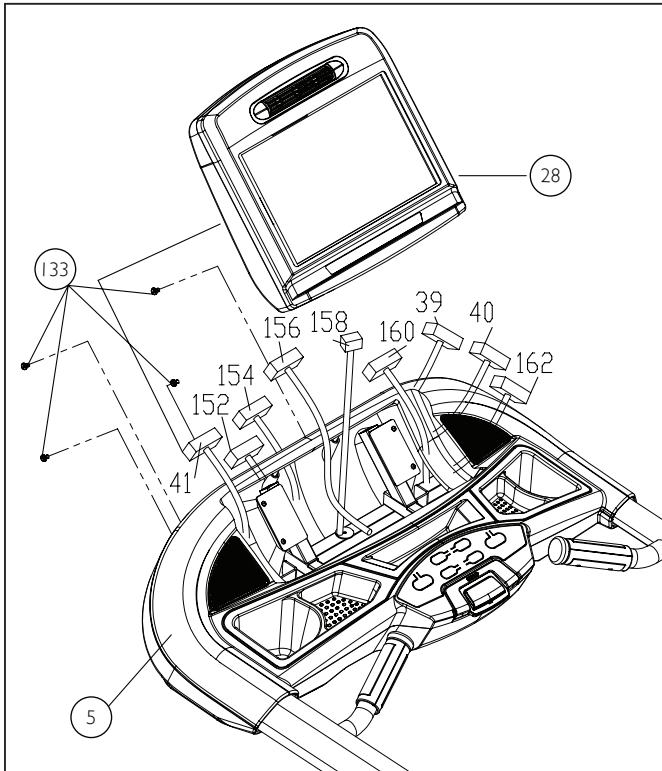

HARDWARE FOR STEP 2

PART	TYPE	DESCRIPTION	QTY
133	SCREW	M5X20	4

1. Connect the Upper **COMPUTER CABLE (41)**, **TV SIGNAL (152)**, **CONSOLE POWER (154)**, **NETWORK (156)**, **CSAFE (158)**, and **HDMI CABLE (160)**. **HAND PULSE WIRE (39|40)** and **GROUND WIRE (162)** to the **BOARD** on the back of the **CONSOLE (28)**.
2. Use 4 **PHILLIPS HEAD SCREWS (133)** to secure console assembly to the **CONSOLE SUPPORT (5)**.

CT850ENT STEP THREE

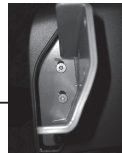
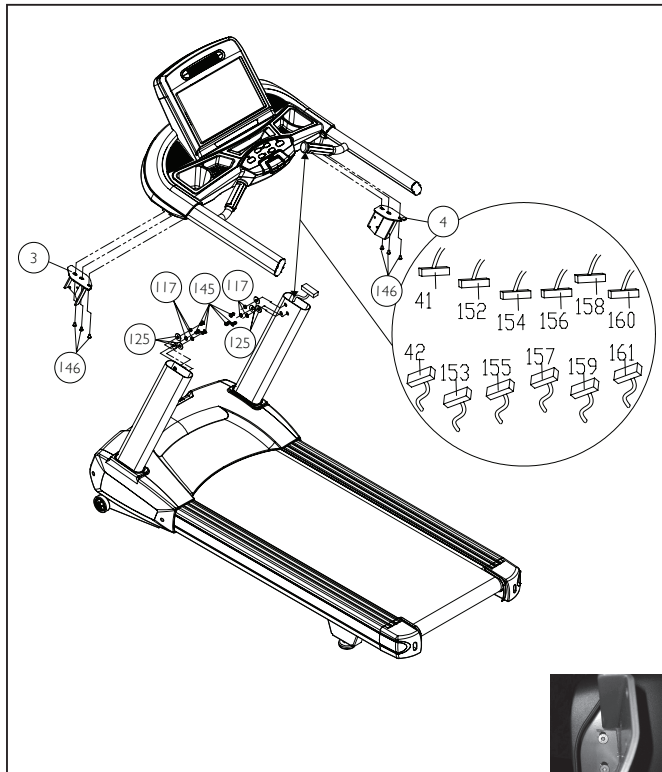

HARDWARE FOR STEP 3

PART	TYPE	DESCRIPTION	QTY
117	SPLIT WASHER	3/8"X16.5X2.0T	6
125	FLAT WASHER	3/8"X2.5X2T	6
145	BOLT	3/8"X3/4"	6
146	BOLT	M8X12	6

1. Use 6 **SOCKET HEAD CAP BOLTS (146)** to secure the console onto the **LEFT AND RIGHT MOUNTING BRACKETS (3-L, 4-R)**. See photo below. *
2. Connect upper computer cable (41) and lower computer cable (42), upper TV Signal Cable (152) and lower TV Signal Cable (153), upper Console Power Cord (154) and lower Console Power Cord (155) upper network W/Cable (156) and lower network W/Cable (157) upper CSAFE W/Cable (158) and lower CSAFE W/Cable (159) upper HDMI Cable (160) and lower HDMI Cable (161) Slide the assembly into the left and right uprights.
3. Slide six **SPLIT WASHERS (117)** and 6 **FLAT WASHERS (125)** onto 6 **BUTTON HEAD SOCKET BOLTS (145)** on top of uprights. Be careful not to pinch the cable.

*When assembling the **CONSOLE MOUNTING INTERFACE BRACKETS (3 & 4)** please be sure to slide the brackets all the way toward the back of the console before tightening the bolts.

CT850ENT STEP FOUR

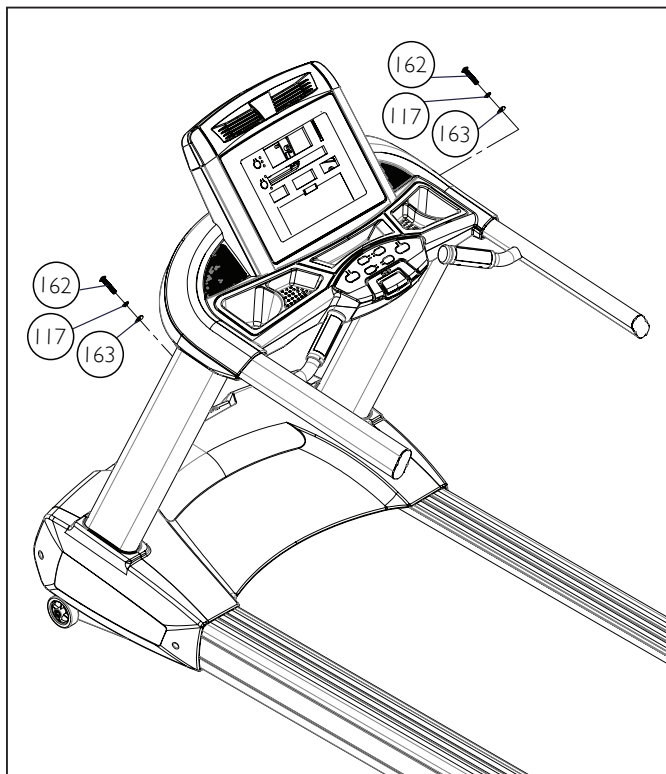

HARDWARE FOR STEP 4

PART	TYPE	DESCRIPTION	QTY
117	SPLIT WASHER	3/8"X16.5X2.0T	2
162	BOLT	3/8"X16X1-3/4"	2
163	CURVED WASHER	10X23X1.5T	2

1. Slide 2 **CURVED WASHERS** (163) and 2 **SPLIT WASHERS** (117) onto 2 **BUTTON HEAD SOCKET BOLTS** (162). Slide the **BOLTS** through the holes on the console masts and tighten.



CT850ENT CONSOLE OPERATION

Large touch-screen LCD

Convenient cargo compartment for buttons, phone, or MP3 player



Fan to keep you cool

Twelve innovative programs offer a variety of workouts

Easy-touch control buttons

STARTING OPERATION

Plug in the power cord located at the front base of the unit. When the power is turned on, the screen will show the initial image and then enter the **Home screen**.

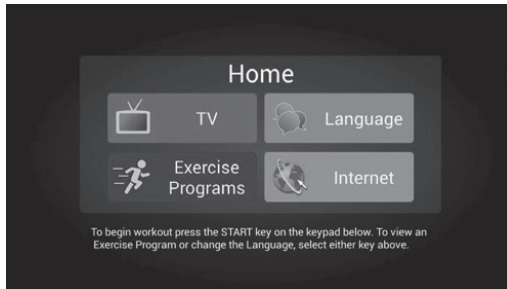

Home Screen: Begin operation by touching the icons.



Quick operating buttons are conveniently located for basic treadmill functions.

SETTINGS

Press the "Home" icon ten consecutive repetitions to enter the Maintenance suite.

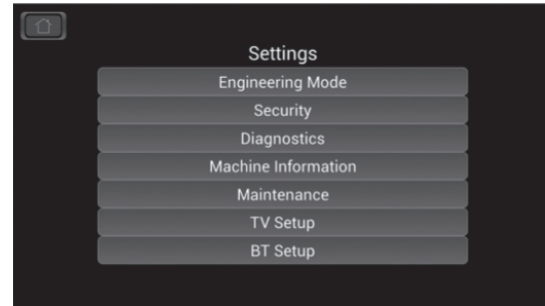
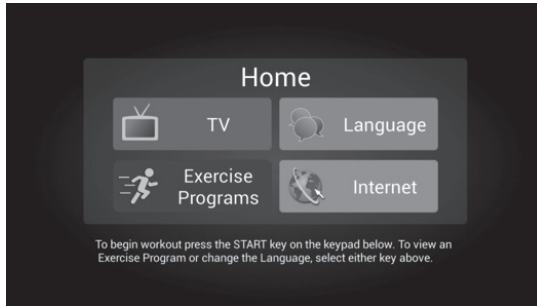

The two most commonly used menus for setting up the exercise machine are described below; the **TV Setup** and **Maintenance** menus. For information on other sections of the Maintenance suite refer to the technical service manual or call Spirit service.

TV SETUP

1. Begin by selecting either **TV** or **HDMI** as the tuner source.
2. Press **OSD Menu**. The first highlighted item on the menu is **Air/Cable** and then **Cable** or **Air** afterward. Press the **OSD Enter** to change the selection between Cable and Air Signal source (usually Cable).
3. After selecting Cable or Air use the arrows located below the **OSD Exit** button to navigate down to **Auto Scan** then press **OSD Enter**. The tuner will now scan for all available channels. Press **OSD Exit** when done. You can modify the channels by pressing the **Update Channel List**.
4. The **OSD Command** button is for engineering use only.



MAINTENANCE MENU

- The **Default language** setup allows you to select the main language that will be shown when the console is turned on. You are able to select the language in the Home menu, but once the user finishes using the machine the console will return to this default language.
- **Software Update Manager** is used to install new versions of the application software.
- **Internet Manager** allows you to modify the internet sites that are shown in the Internet menu.
- **Wifi/Ethernet Setup** is for selecting a Wifi signal or Ethernet addresses.
- **Machine Setup** allows you to select whether the Csafe port is used for Csafe or CAB TV Tuner. This menu also allows you to set the screen brightness.
- **FTP Settings** is the Spirit FTP site address where error logs and remote troubleshooting can be managed.

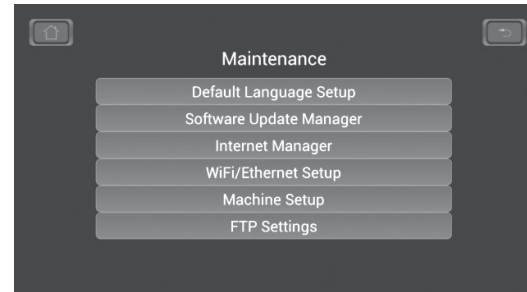

INTERNET MANAGER

1. Remove a link by pressing the icon of the site you want to remove for two seconds. A pop-up window will ask you to confirm the removal.
2. To add a website press the dotted outline box. A pop-up window will ask you to enter the web address and upload a picture for the final button if you wish. You could also just use a default-look button and type in the name of the site, which will then be the button icon.



WIFI/ETHERNET SETUP

Press the desired button for setting up **Wifi** or **Ethernet**.



WIFI SETUP

Turn **Wifi** on and press scan for available Wifi connections. Press desired connection and follow the on-screen directions.



ETHERNET SETUP

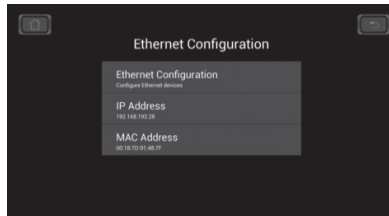

Press **Ethernet Configuration** to set up a new connection.

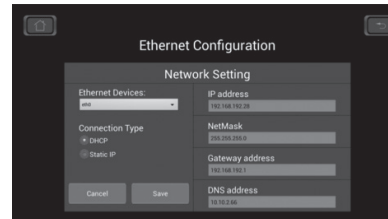

Select **DHCP** to search for connection or **Static IP** to enter manually

BLUETOOTH PAIRING PROCEDURE

1. Press the **Blue Tooth (BT) icon** on the bottom left of the screen.
2. The **BT pop-up screen** will appear. Turn on **Phone/tablet BT** and then press **Pair Mode** on ENT Menu.
3. The menu will show **Entering Pairing** mode and the phone will show **A2DP** as an available device.
4. The **A2DP** console and phone will ask you to confirm pairing, press **OK**.
5. Pairing complete.
6. Open audio APP on phone and the audio will be played through the headphone port on the ENT console.

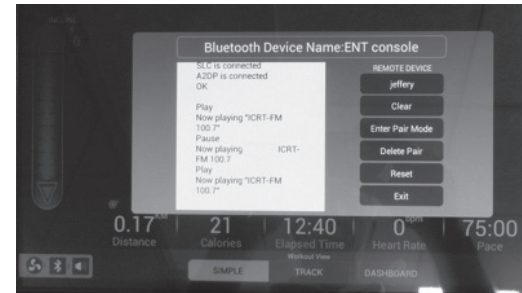

TOUCH SCREEN OPERATION

LANGUAGE

When you press the **Language button** on Home screen, it enters the menu with all language options.

There are 12 languages to choose from. Touch the desired language and the system will return to the Home screen which will now be in the chosen language.



TV

When the **TV button** on the Home screen is pressed, it directly enters TV interface.

Now you can enjoy TV programs. If you want to enjoy TV while exercising, press **Start button** at front of the treadmill to initiate **Quick Start** or press **Programs** to select a workout.

You can change the TV channels by pressing the channel up/down buttons on the right side of the screen. You can also use the **Volume Up/Down buttons** to change the sound levels. If you want to silence the audio touch **Mute button**. Touch the **Max Screen** to switch to full screen viewing. Touching anywhere on the screen will return it to the original screen size.



INTERNET

When the **Internet button** on the Home page is pressed, you are directed to Internet interface.

There are 6 basic internet sites to choose from. You may change or add other sites through the Maintenance program (more on this later in the manual in the System Maintenance Suite section).

NOTE: An internet cable connection or WIFI connection is required.



EXERCISE PROGRAMS

When the **Exercise Program button** on the Home page is pressed, the fitness program menu appears.

There are 12 programs to choose from. Press the desired program button and follow the on-screen directions. For **Manual Program** as an example, just touch **Manual button** on the screen to enter the programming for **Manual**.



FUNCTIONS OF THIS TREADMILL

The Touch-control screen is used for operating all functions of the treadmill. You can directly touch any button on the screen or through quick buttons on the forward pod to control functions. On the forward pod, there are Fast/Slow buttons to control the speed, Start button to begin the workout, **Stop** button to pause/stop running, **Incline Up/Down** buttons to control the incline of the treadmill.

QUICK START

Press any button to wake display up if not already on.

- Press the **Start button** to begin belt movement at 0.5 mph then adjust to the desired speed using the **Speed +/-** button, or by typing the desired speed on the numeric keypad. Once setting desired is selected press Enter.
- To stop the treadbelt press and release **Stop button**.

PAUSE/STOP/RESET

When the treadmill is running the pause feature may be utilized by pressing the red Stop button once. This will slowly decelerate the treadbelt to a stop. The incline will go to zero percent. The **Time**, **Distance** and **Calorie** readings will hold while the unit is in the pause mode. After 5 minutes the display will reset and return to the start-up screen.

- To resume your exercise when in **Pause mode**, press the **Start button**. The speed and incline will return to their previous settings.
- Pressing the **Stop button** twice will end the program and a workout summary will be displayed. If the **Stop button** is pressed a third time, the console will return to the idle mode (start-up screen).
- If the **Stop button** is held down for more than three seconds the console will reset.
- When you are setting data, such as age and time, for a program pressing the **Stop button** will allow you to go back one step for each button press.

INCLINE

- Incline may be adjusted any time after the belt starts moving.
- Press and hold the adjustment **Incline +/- buttons** to achieve desired level of incline.
- The display will indicate incline numbers as percent of grade (the same as grade of a road) as adjustments are made.

DISPLAY OPTIONS

SIMPLE

The default display at the start of a program is a **Simple display**. The profile window shows the work level graphically. All your workout values are displayed on the bottom of the screen. Some of the data windows have a + sign at the top indication more data available. Press the data window to see other information available.

Below the profile window are buttons that allow you to switch the display between the speed and incline profiles. Below the data displays are **Track** and **Dashboard** buttons for selecting other display options. A muscle profile displays active muscle groups as workloads change.



TRACK

The **Track display** gives a graphical representation of your position on a virtual track. The image shows the track with a lap counter and other values.



DASHBOARD

The **Dashboard display** shows a larger display area of key information.



STOP BUTTON

When using the **Stop button** to end the program, it enters the summary screen.

On the summary screen, all accumulated values concerning the workout are displayed. You can touch the **Home button** at left top or press **Stop button** to return to the home screen.

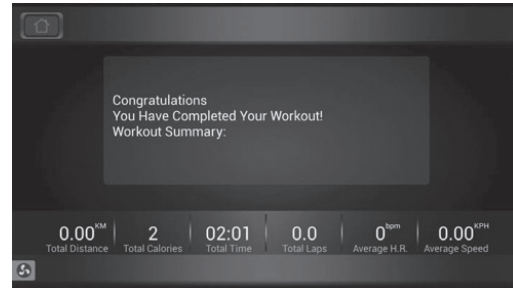

HEART RATE FEATURE

The **Pulse (Heart Rate)** on the screen shows the current value of the heart beats per minute. You must use both left and right stainless steel sensors to pick up your pulse. Pulse values are displayed anytime the computer is receiving a **Grip pulse** signal. You may use the **Grip pulse** feature while in Heart Rate Control. The CT850ENT will also pick up wireless heart rate transmitters that are Polar compatible.

TO TURN TREADMILL OFF:

The screen will automatically turn off (go to sleep) after 30 minutes of inactivity. This function is called sleep mode. In sleep mode, the treadmill will power down most everything except for a minimum of circuitry for detecting button presses and the safety key so it will start up again if these are activated. There is only a tiny amount of current used in sleep mode (about the same as your TV when it is turned off) and it is perfectly fine to leave the main power switch on in sleep mode. Of course you may also remove the safety key or turn off the main power switch to power down the treadmill.

PROGRAMMABLE FEATURES

Each of the programs can be customized with your personal information and changed to suit your needs. Some of the information asked for is necessary to ensure the readouts are correct. You will be asked for your **Age** and **Weight**. Entering your **Age** ensures that the Heart Rate bar graph shows the correct number. Your **Age** is also necessary during the **Heart Rate** control program to ensure the correct settings are in the program for your **Age**. Otherwise the work settings could be too high or low for you; entering your **Weight** aides in calculating a more correct **Calorie** reading. Although we cannot provide an exact calorie count we do want to be as close as possible.

CALORIE NOTE: Calorie readings on every piece of exercise equipment, whether it is in a gym or at home, are not accurate and tend to vary widely. They are meant only as a guide to monitor your progress from workout to workout. The only way to measure your calorie burn accurately is in a clinical setting connected to a host of machines. This is because every person is different and burns calories at a different rate. Some good news is that you will continue to burn calories at an accelerated rate for at least an hour after you have finished exercising!

ENTERING A PROGRAM & CHANGING SETTINGS

The Spirit Fitness CT850ENT offers a variety of exercise program options to choose from: **Manual, Hill, Fat Burn, Cardio, Strength, 5k Run, Interval, HR, Custom, Fitness Test (Air Force, Army, Coast Guard, Gerkin, PEB, Marine Corps, Navy, WFI), Calories, and 10k Run.** To select and start a preset program:

1. Select a preset program button then press **Enter** to begin customizing the program with your personal data, or just press the **Start button** to begin the program with the default settings.
2. After selecting a program and pressing enter to set your personal data, the **Message window** will prompt you through the settings starting with time. The default value of 20 minutes will be displayed and you may press **Enter** to accept or change it using the keypad and just press **Enter** to move to the next step
3. The **Age window** will now be displaying a value indicating your Age. (Entering the correct Age will affect the Heart rate bar graph accuracy and also needed for the HR programs. Use numeric key pads to make adjustments, and then press **Enter** confirm. Default age is 30 years old. Range=10 to 110).
4. The **Weight window** will now be showing a value indicating your Bodyweight. (Entering your correct bodyweight affects the Kcal readout accuracy. Use the numeric key pad to make adjustments, and press the **Enter** button to confirm. Default weight is 70KG. Range=10 to 150).
5. The **Message Window** will now be showing the preset top speed of the selected program. Use the keypad to adjust and then press **Enter**. Each program has various speed changes throughout; this allows you to limit the highest speed the program will attain during your workout.
6. Now press the **Start button** to begin your workout, or the **Stop button** to return to the previous screen.
7. There will be a 3-minute warm-up to begin. You can press the **Start button** to bypass this and go straight to the workout. During the warm-up the clock will count down from three minutes.

PRESET PROGRAMS SPEED/INCLINE SETTINGS

The preset program **Speed** and **Incline** levels are shown in the chart below. The **Speed** numbers shown in the chart indicate a percentage of the top speed of the program. For instance, the first **Speed** setting for P1 (Program 1, HILL) shows the number 20. This means that this segment of the program will have a speed that is 20% of the top speed for the program (The user sets the top speed in the procedure above). If the user sets the top speed to 10 mph, then the first segment will be 2 mph. You will notice that segment 12 shows 100 which means the speed will be set to 100% of 10 mph or simply 10 mph.

Prog	SEG	Warm up				1	2	3	4	5	6	7	8	9	10	11	12	13	14	15	16	17	18	19	20	Cool down		
Hill	Speed	20	30	40	50	62.5	62.5	70	70	75	75	87.5	87.5	100	100	87.5	87.5	75	75	70	70	62.5	62.5	80	40	30	20	
	Incline	0	0	0	0	1	2	3	3	4	3	4	4	5	3	4	3	4	5	4	3	1	1	0	0	0	0	
Fatburn	Speed	20	30	40	50	62.5	75	100	100	100	100	100	100	100	100	100	100	100	100	100	100	100	75	50	40	30	20	
	Incline	0	0	0	0	1	2	3	3	4	5	3	4	4	3	2	3	4	5	6	4	2	1	0	0	0	0	
Cardio	Speed	20	30	40	50	60	60	70	70	70	80	70	70	80	80	60	70	80	80	70	70	70	100	70	40	30	20	
	Incline	0	0	0	0	1	1	2	2	3	2	2	3	1	2	3	2	2	4	2	3	1	1	0	0	0	0	
Strength	Speed	20	30	40	50	62.5	62.5	70	70	75	75	80	80	87.5	95	95	100	100	100	100	100	100	87.5	75	50	40	30	20
	Incline	0	0	0	0	1	2	4	6	8	7	6	5	4	3	3	4	5	7	7	5	3	1	0	0	0	0	
Interval	Speed	20	30	40	50	62.5	62.5	100	100	62.5	62.5	100	100	62.5	62.5	100	100	62.5	62.5	100	10	62.5	62.5	50	40	30	20	
	Incline	0	0	0	0	1	2	3	5	2	3	6	2	3	7	2	3	8	2	3	5	3	1	0	0	0	0	

MANUAL

Both **Speed** and **Incline** are controlled by the user. Increase or decrease levels at any time during your workout.

HILL

Speed: This program follows a triangle or pyramid type of gradual progression from approximately 10% of maximum effort (the level that you choose before starting this program) up to a maximum effort which lasts for 10% of the total workout time, then a gradual regression of Speed back to approximately 10% of maximum effort

Incline: The deck elevation is a more gradual and sustained progression. Maximum elevation is in the middle of the workout and lasts for 10% of the duration.

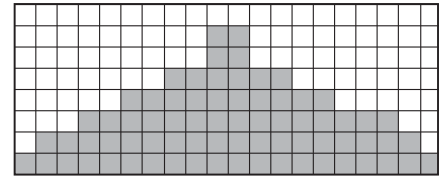

FAT BURN

Speed: This program follows a quick progression up to the maximum speed level (default or user input level) that is sustained for 2/3 of the workout. This program will challenge your ability to sustain your energy output for an extended period of time.

Incline: The deck elevation is a quick and sustained progression up to the maximum value (default or user input) for 90% of the workout duration.

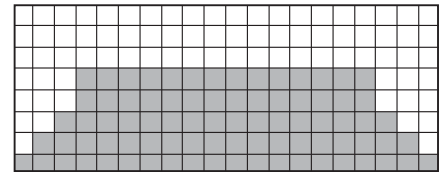

CARDIO

Speed: This program presents a quick progression up to near maximum speed level (default or user input level). It has slight fluctuations up and down to allow heart rate to elevate, and then recover repeatedly, before beginning a quick cool down. This will build up your heart muscle and increase blood flow and lung capacity.

Incline: The elevation in this program is moderate. There are several elevation spikes at different points of the workout. Segments 4, 9, and 14 are maximum elevation for this program.

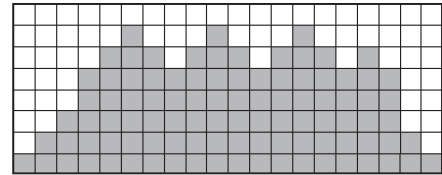

STRENGTH

Speed: This program has a gradual progression of speed up to 100% of maximum effort that is sustained from 25% of workout duration. This will help build strength and muscular endurance in the lower body and glutes. A brief cool down follows.

Incline: There is a quick climb to a moderate, sustained elevation that lasts the majority of the workout length.

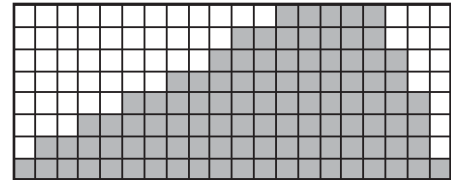

5K RUN

Both speed and incline are controlled by the user. Increase or decrease levels at any time during your workout. The track display will set the distance of 1 lap to 5 kilometers (metric) or 3.1 miles (standard measurement).

INTERVAL

Speed: This program takes you through high levels of intensity followed by recovery periods of low intensity. This program utilizes and develops your "Fast Twitch" muscle fibers which are used when performing tasks that are intense and short in duration. These deplete your oxygen level and spike your heart rate, followed by periods of recovery and heart rate drop to replenish oxygen.

Incline: All of your lower extremity muscles will be equally challenged throughout this program. The incline alternates between 25% and 65% of maximum elevation.

HR

The default value is 65% of your projected rate maximum. You have the option of changing your target heart rate. The machine will attempt to keep you within five beats of your target heart rate.

CUSTOM

You will create the desired speed and incline levels for each of the 20 segments of the program using the pop out keyboard on the screen. After the program has started, you still have the ability of changing these levels whenever you desire.

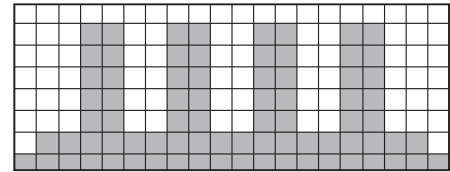

FITNESS TEST

When the **Fit test button** is pressed the DM displays: **GERKIN**. This is the first of 8 different tests available: **Air Force, Army, Coast Guard, Gerkin, PEB, Marine Corps, Navy, and WFI**. The initial test is **GERKIN**; to select a different test press the **Fitness Test button** again and the next test will be shown. Continue to press the **Fitness test button** until the test you want is shown in the message window. To select your desired fitness test, press **Enter**.

Fit Test Operation:

1. For each program the Message Window will prompt you to enter your personal data such as **Age, Weight, Height, Gender**. You may adjust the settings using the keypad or Up and Down buttons then press the **Enter button** to accept the new number and proceed on to the next screen.
2. After all required data is entered you may now press **Start** to begin the test.

AIR FORCE

A timed 1.5 mile run. You control the speed manually. Maximum time allowed to pass the test:

Age	Male	Female
<20	12:36	16:22
20-30	14:00	16:57
40-49	14:52	18:14
50-59	16:22	19:42
60+	18:14	22:28

For more detailed information, visit: <http://bit.ly/SF-AirForce>

ARMY

A timed 2 mile run. You control the speed manually. Maximum time allowed to pass the test.

Age	Male	Female
17-21	16:36	19:42
22-26	17:30	20:36
27-31	17:54	21:42
32-36	18:48	23:06
37-41	19:30	24:06

For more detailed information, visit: <http://bit.ly/SF-Army>

NAVY

A timed 1.5 mile run. You control the speed manually. Maximum time allowed to pass the test:

Age	Male	Female
17-21	16:36	19:42
22-26	17:30	20:36
27-31	17:54	21:42
32-36	18:48	23:06
37-41	19:30	24:06

Age	Male	Female
45-49	16:09	17:02
50-54	16:46	17:27
55-59	17:10	18:35
60-64	18:53	19:44
65+	20:36	20:53

For more detailed information, visit: <http://bit.ly/SF-Navy>

MARINES

A timed 3 mile run. You control the speed manually. Maximum time allowed to pass the test:

Age	Male	Female
17-26	28:00	31:00
27-39	29:00	32:00
40-45	30:00	33:00
46+	33:00	36:00

For more detailed information, visit: <http://bit.ly/SF-Marines>

GERKIN

The **Gerkin** protocol, also known as the fireman's protocol, is a sub-max VO₂ (volume of oxygen) test. The test will increase speed and elevation alternately until you reach 85% of your Max heart rate. The time it takes for you to reach 85% determines the test score (VO₂max) as shown in the chart below.

Stage	Time	Speed	Grade	VO ₂ Max					
1	0 to 1:00	4.5mph	0%	31.15	6.4	6:00	6.0mph	6%	57
2.1	1:00	4.5mph	2%	32.55	7.1	6:15	6.0mph	6%	57.7
2.2	1:30	4.5mph	2%	33.6	7.2	6:30	6.0mph	6%	58.8
2.3	1:45	4.5mph	2%	34.65	7.3	6:45	6.0mph	6%	60.2
2.4	2:00	5.0mph	2%	35.35	7.4	7:00	6.0mph	8%	61.2
3.1	2:15	5.0mph	2%	37.45	8.1	7:15	6.0mph	8%	62.3
3.2	2:30	5.0mph	2%	39.55	8.2	7:30	6.0mph	8%	63.3
3.3	2:45	5.0mph	2%	41.3	8.3	7:45	6.0mph	8%	64
3.4	3:00	5.0mph	4%	43.4	8.4	8:00	6.5mph	8%	65
4.1	3:15	5.0mph	4%	44.1	9.1	8:15	6.5mph	8%	66.5
4.2	3:30	5.0mph	4%	45.15	9.2	8:30	6.5mph	8%	68.2
4.3	3:45	5.0mph	4%	46.2	9.3	8:45	6.5mph	8%	69
4.4	4:00	5.5mph	4%	46.5	9.4	9:00	6.5mph	10%	70.7
5.1	4:15	5.5mph	4%	48.6	10.1	9:15	6.5mph	10%	72.1
5.2	4:30	5.5mph	4%	50	10.2	9:30	6.5mph	10%	73.1
5.3	4:45	5.5mph	4%	51.4	10.3	9:45	6.5mph	10%	73.8
5.4	5:00	5.5mph	6%	52.8	10.4	10:00	7.0mph	10%	74.9
6.1	5:15	5.5mph	6%	53.9	11.1	10:15	7.0mph	10%	76.3
6.2	5:30	5.5mph	6%	54.9	11.2	10:30	7.0mph	10%	77.7
6.3	5:45	5.5mph	6%	56	11.3	10:45	7.0mph	10%	79.1
					11.4	11:00	7.0mph	10%	80

Before The Test:

- Make sure you are in good health; check with your physician before performing any exercise if you are over the age of 35 or persons with pre-existing health conditions.
- Make sure you have warmed up and stretched before taking the test.
- Do not take in caffeine before the test.
- Hold the hand grips gently, do not tense up.

During the Test:

- The console must be receiving a steady heart rate for the test to begin. You may use the hand pulse sensors or wear a heart rate chest strap transmitter.
- The test will start with a 3-minute warm-up at 3 MPH before the actual test begins.
- The data shown during the test is:
 1. **Time** indicates total elapsed time
 2. **Incline** in percent grade
 3. **Distance** in miles or kilometers depending on preset parameter.
 4. **Speed** in mph or kph depending on preset parameter.
 5. **Target heart rate** and **Actual heart rate** are shown in the **Message window**.

After the Test:

- Cool down for about one to three minutes.
- Take note of your score because the console will automatically return to the start-up mode after a few minutes.

What Your Score Means:

VO2MAX CHART FOR MALES AND VERY FIT FEMALES

	18-25 years old	26-35 years old	36-45 years old	46-55 years old	56-65 years old	65+ years old
excellent	>60	>56	>51	>45	>41	>37
good	52-60	49-56	43-51	39-45	36-41	33-37
above average	47-51	43-48	39-42	35-38	32-35	29-32
average	42-46	40-42	35-38	32-35	30-31	26-28
below average	37-41	35-39	31-34	29-31	26-29	22-25
poor	30-36	30-34	26-30	25-28	22-25	20-21
very poor	<30	<30	<26	<25	<22	<20

VO2MAX CHART FOR FEMALES AND DECONDITIONED MALES

	18-25 years old	26-35 years old	36-45 years old	46-55 years old	56-65 years old	65+ years old
excellent	56	52	45	40	37	32
good	47-56	45-52	38-45	34-40	32-37	28-32
above average	42-46	39-44	34-37	31-33	28-31	25-27
average	38-41	35-38	31-33	28-30	25-27	22-24
below average	33-37	31-34	27-30	25-27	22-24	19-22
poor	28-32	26-30	22-26	20-24	18-21	17-18
very poor	<28	<26	<22	<20	<18	<17

CALORIE PROGRAM

Speed: This program follows a progression up to the maximum speed level (default or user input level) that is sustained for 2/3 of the workout. This program will challenge your ability to sustain your energy output for an extended period of time.

Incline: The treadmill elevation is a quick and sustained progression up to the maximum value (default or user input) for 90% of the workout duration.

IOK RUN

Both speed and Incline are controlled by the user. Increase or decrease levels at any time during your workout. The track Display will set the distance of 1 Lap to 10 kilometers (metric) or 6.2 miles (standard measurement).

HEART RATE PROGRAM

Heart Rate Control (HRC) uses your treadmill's incline system to control your heart rate via information from pulse grips or wireless chest strap. Increases and decreases in elevation affect heart rate much more efficiently than changes in speed alone. The **HRC** program automatically changes elevation gradually to achieve the programmed target heart rate.

Selecting a **Heart Rate Control Program**:

You have the option, during the set up mode, to choose either the **Weight control (HR 1) program** or the **Cardiovascular (HR 2) program**. The **Weight control program** will attempt to maintain your heart rate at 60% of your Maximum Heart Rate. The **Cardiovascular program** will attempt to maintain your heart rate at 85% of your Maximum Heart Rate. Your Maximum Heart Rate is based upon a formula that subtracts your age from a constant of 220. Your HR setting is automatically calculated during the setup mode when you enter your age.

Heart Rate Control programming:

1. Press **HR button** to enter heart rate program.
2. Now the window will show PRESS ENTER TO MODIFY OR START TO BEGIN WORKOUT. You can either press the **Enter** button for settings or press the Start button to execute the program.
3. When the Enter button is pressed, the **Message window** shows PRESS 1 OR 2 TO SELECT THEN PRESS ENTER. At the same time, the dot matrix window is showing "1" and you can press numeric keypad 1 or 2 and then the **Enter** button.
4. Now Message Window is showing ADJUST TIME THEN PRESS ENTER with **Time Window** blinking. Use **Up/Down buttons** or numeric keys to adjust. After setting time, press the Enter button again.
5. Now **Message window** is showing ADJUST AGE THEN PRESS ENTER with Incline Window blinking. Use **Up/Down/ Fast/Slow buttons** or numeric keys to adjust. Adjusting age will change HR value (as the HR formula described previously). After age is set, press the **Enter** button again.

6. Now **Message window** is showing ADJUST BODY WEIGHT THEN PRESS ENTER with **Incline Window** blinking. Use **Up/Down buttons** or numeric keys to adjust. After the weight is set, press **Enter button** again.
7. Now **Message window** is showing ADJUST HEART RATE THEN PRESS ENTER with **Speed Window** blinking. Use **Up/Down buttons** or **Numeric keys** to adjust. After the target heart rate value is set, press the **Enter button** again.
8. The **Message window** is then showing PRESS START TO BEGIN WORKOUT OR ENTER TO MODIFY. Press **Start button** to begin the workout or **Stop button** to return to the previous screen.

Note: When the Message Window is showing CHECK PULSE, there is no pulse signal received and the program cannot be performed. Please check and make sure that heart rate strap functions normally.

SAFETY TETHER CORD

A safety tether cord is provided with this unit. It is a simple magnetic design that should be used at all times. It is for your safety should you fall or move too far back on the treadbelt. Pulling this safety tether cord will stop treadbelt movement. To Use:

1. Place the magnet into position on the round metal portion of the console control head. Your treadmill will not start and operate without this. Removing the magnet also secures the treadmill from unauthorized use.
2. Fasten the plastic clip onto your clothing securely to assure good holding power. *NOTE: The magnet has strong enough power to minimize accidental, unexpected stopping. The clip should be attached securely to make certain it does not come off. Be familiar with its function and limitations. The treadmill will stop, depending on speed, with a one to two step coast anytime the magnet is pulled off the console. Use the **Stop/Pause button** in normal operation.*

GENERAL MAINTENANCE

Unplug treadmill before performing any maintenance.

Task	How To	Daily	Weekly	Monthly	Semi-Annually
Wipe Down Unit	Damp cloth w/ water	•			
Clean Under Belt	Towel or vacuum			•	
Check Belt Tension/Tracking	Feel/Visual		•		
Clean Under Motor Cover	Vacuum carefully				•
Check Hardware	Wrench			•	
Inspect for Deck Wear	Visual				•
Inspect Drive Belt	Visual				•

BELT/DECK

Your treadmill uses a very high-efficient low-friction hard waxed deck. Performance is maximized when the deck is kept as clean as possible. Use a soft, damp cloth, or paper towel, wipe the edge of the belt and the area between the belt edge and the frame. Also reach as far as practical directly under the belt edge. This should be done once a month to extend belt and deck life. A mild soap and water solution along with a nylon scrub brush will clean the top of the textured belt. Allow to dry before using.

The low maintenance (routine monthly cleaning), dual sided hard wax deck is designed to withstand up to 20,000 miles on each side. If the original side of the deck shows significant wear, it needs to be flipped. Contact your service technician for assistance. Do not apply any type of lubricant or wax to the surface.

BELT ADJUSTMENTS

Belt tension is not critical for most users. It is very important though for joggers and runners in order to provide a smooth, steady running surface. Adjustment must be made from the rear roller with the 8mm Allen wrench provided in the parts package. The adjustment bolts are located at the end of the step rails as shown in the diagram below.

Tighten the rear roller only enough to prevent slippage at the front roller. Turn the tread-belt tension adjusting bolts $1/4$ turn each and inspect for proper tension by walking on the belt and making sure it is not slipping or hesitating with each step. When an adjustment is made to the belt tension, you must be sure to turn the bolts on both sides evenly or the belt could start tracking to one side instead of running in the middle of the deck.

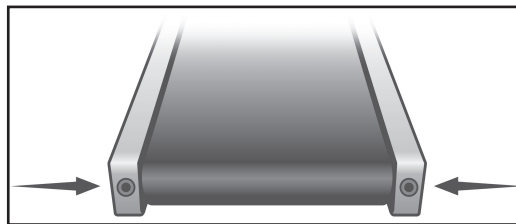

DO NOT OVER TIGHTEN – Over tightening will cause belt damage and premature bearing failure. If you tighten the belt a lot and it still slips, the problem could actually be the drive belt - located under the motor cover - that connects the motor to the front roller. If that belt is loose it feels similar to the walking belt being loose. Tightening the motor belt should be done by a trained service person.

TREADBELT TRACKING ADJUSTMENT

The treadmill is designed so that the tread-belt remains reasonably centered while in use. It is normal for some belts to drift near one side while in use, depending on a user's gait and if they favor one leg. But if during use the belt continues to move toward one side, adjustments are necessary.

Setting Tread-Belt Tracking:

An 8mm Allen wrench is provided for this adjustment. Make tracking adjustments on the left side bolt. Set belt speed at 3 mph. Be aware that a small adjustment can make a dramatic difference which may not be apparent right away. If the belt is too close to the left side, then turn the bolt only a 1/4 turn to the right (clockwise) and wait a few minutes for the belt to adjust itself. Continue to make 1/4 turns until the belt stabilizes in the center of the running deck.

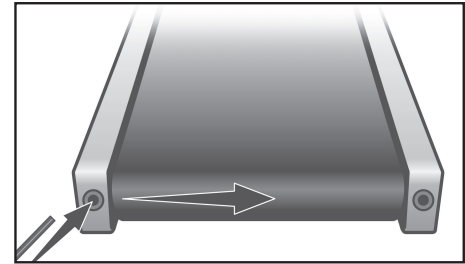

If the belt is too close to the right side, turn the bolt counter-clockwise. The belt may require periodic tracking adjustment depending on use and walking/running characteristics. Some users may affect tracking differently. Expect to make adjustments as required to center the tread-belt. Adjustments will become less of a maintenance concern as the belt is used. Proper belt tracking is an owner responsibility common with all treadmills.

ATTENTION: Damage to the running belt resulting from improper tracking / tension adjustments is not covered under the Spirit Fitness warranty.

CALIBRATION PROCEDURE

1. Remove the safety button.
2. Press and hold down the **Start** and **Fast +** buttons and replace the safety button. Continue to hold the **Start** and **Fast** button until the window displays "Factory settings", then press the **Enter** button.
3. You will now be able to set the display to show Metric or English settings (Miles vs. Kilometers). To do this, press the **up** or **down** button to show which you want, then press Enter.
4. Make sure the wheel size diameter is 2.98 then press **Enter**.
5. Adjust the minimum speed (if needed) to 0.5 and then press **Enter**.
6. Adjust the maximum speed (if needed) to 12.0 and then press **Enter**.
7. Adjust the maximum elevation (if needed) to 15 and then press **Enter**.
8. Grade return – On (This allows the incline to return to zero when **Stop** is pressed. For sale in Europe, EU standards require this to be off).
9. Press **Start** to begin calibration. The process is automatic; the speed will start up without warning, so do not stand on the belt.

ADJUSTING THE SPEED SENSOR

If the calibration does not pass you may need to check the speed sensor alignment.

1. Remove the motor cover hood by loosening the 8 screws that hold it in place. Set it aside.
2. The speed sensor is located on the left side of the frame, right next to the front roller pulley (the pulley will have a belt around it that also goes to the motor). The speed sensor is a small rectangular shaped black box with a wire connected to it.
3. You will see a magnet on the outside edge of the pulley; make sure the speed sensor is aligned with the center of the magnet when it passes by. There are two screws that hold the sensor in place that need to be loosened to adjust the sensor. Re-tighten the screws when finished.



TROUBLESHOOTING

PROBLEM	CAUSE
Display does not light	<ol style="list-style-type: none"> 1. Tether cord not in position. 2. Circuit breaker on front grill tripped. Push circuit breaker in until it locks. 3. Plug is disconnected. Make sure plug is firmly pushed into 115 VAC wall outlet. 4. Breaker panel circuit breaker may be tripped. 5. Treadmill defect. Contact your Spirit Fitness dealer.
Treadbelt does not stay centered Treadmill belt hesitates when walked/run on	The user may be walking while favoring or putting more weight on either the left or right foot. If this walking pattern is natural, track the belt slightly off-center to the side opposite from the belt movement. See General Maintenance section on Treadbelt Tension . Adjust as necessary.
Motor is not responsive after pressing start	<ol style="list-style-type: none"> 1. If the belt moves, but stops after a short time and the display shows "LS", run calibration. 2. If you press start and the belt never moves, then the display shows LS, contact service.
Circuit breaker trips, but not the treadmill circuit breaker	Need to replace the breaker with a "High In-rush current" type breaker (see page 4 for details)
Treadmill will only achieve approximately 12 mph but shows higher speed on display	This indicates motor should be receiving power to operate. Do not use an extension cord. If an extension cord is required, it should be as short as possible and heavy duty, 16-gauge minimum, low voltage. Contact an electrician or your Spirit Fitness dealer. A minimum of 110-volt AC current is required.
Treadbelt stops quickly/suddenly when tether cord is pulled	High belt/deck friction. If cleaning doesn't prevent this from reoccurring, check to see if there is significant wear of the deck. If so, the deck may need to be flipped if it is on its original side.
Treadmill trips on board 20 amp circuit	High belt/deck friction. If cleaning doesn't prevent this from reoccurring, check the amp draw of the motor. If this is high and there are signs of significant wear of the deck, it may need to be flipped on its original side.
Computer shuts off when console is touched (on a cold day) while walking/running	Treadmill may not be grounded. Static electricity is crashing the computer. Refer to Grounding Instructions .

TREADMILL WARRANTY EFFECTIVE JANUARY 1, 2017

Spirit Fitness warrants all its treadmill parts for a period of time listed below from the date of retail sale, as determined by sale receipt, or in the absence of a sales receipt eighteen (18) months from the original factory shipping date. Spirit Fitness' responsibilities include providing new or remanufactured parts, at Spirit Fitness' option, and technical support to our independent dealers and servicing organizations. In the absence of a dealer or service organization, these warranties will be administered by Spirit Fitness directly to a facility. The warranty period applies to the following components:

WARRANTY Commercial (Non-Dues Paying Facilities)	FRAME Lifetime	MOTOR & DECK 5 Years	PARTS 5 Years	LABOR 2 Years	CONSOLE PARTS: 3 Years	CONSOLE LABOR: 1 Year
--	--------------------------	------------------------------------	-------------------------	-------------------------	----------------------------------	---------------------------------

NORMAL RESPONSIBILITIES OF THE FACILITY

The non-dues paying facility is responsible for the items listed below:

1. The warranty registration card must be completed and returned to the address listed on the card within 10 days of the original purchase, or completed online to validate the manufacturer's limited warranty.
2. Proper use of the fitness equipment in accordance with the instructions provided in this manual
3. Proper installation in accordance with instructions provided with the fitness equipment and with all local electric codes.
4. Proper connection to a grounded power supply of sufficient voltage, replacement of blown fuses, repair of loose connections or defects in house or facility wiring.
5. Expenses for making the fitness equipment accessible for servicing, including any item that was not part of the fitness equipment at the time it was shipped from the factory.
6. Damages to the fitness equipment finish during shipping, installation or following installation.
7. Routine maintenance of this unit as specified in this manual.

EXCLUSIONS

This warranty does not cover the following:

1. CONSEQUENTIAL, COLLATERAL, OR INCIDENTAL DAMAGES SUCH AS PROPERTY DAMAGE AND INCIDENTAL EXPENSES RESULTING FROM ANY BREACH OF THIS WRITTEN OR ANY IMPLIED WARRANTY.
NOTE: Some states do not allow the exclusion or limitation of incidental or consequential damages, so this limitation or exclusion may not apply to you.
2. Service call reimbursement to the consumer. Service call reimbursement to the dealer that does not involve malfunction or defects in workmanship or material, for units that are beyond the warranty period, for units that are beyond the service call reimbursement period, for fitness equipment not requiring component replacement, or fitness equipment not in non-dues paying facility or household use.
3. Damages caused by services performed by persons other than authorized Spirit Fitness service companies; use of parts other than original Spirit Fitness parts; or external causes such as corrosion, discoloration of paint or plastic, alterations, modifications, abuse, misuse, accident, improper maintenance, inadequate power supply, or acts of God.
4. Products with original serial numbers that have been removed or altered.
5. Products that have been: sold, transferred, bartered, or given to a third party.
6. Products that do not have a warranty registration card on file at Spirit Fitness. Spirit Fitness reserves the right to request proof of purchase if no warranty record exists for the product.
7. THIS WARRANTY IS EXPRESSLY IN LIEU OF ALL OTHER WARRANTIES EXPRESSED OR IMPLIED, INCLUDING THE WARRANTIES OF MERCHANTABILITY AND/OR FITNESS FOR A PARTICULAR PURPOSE.
8. Product used in a dues paying facility (YMCA, Health Club, Etc.)
9. Product used in prisons and correctional facilities
10. Warranties outside of the United States may vary. Please contact your local dealer for details.

SERVICE

Keep your bill of sale. Twelve (12) months from the date on the bill of sale or eighteen (18) months from the date of factory shipping as determined by the serial number establishes the labor warranty period should service be required. If service is performed, it is in your best interest to obtain and keep all receipts. This written warranty gives you specific legal rights. You may also have other rights that vary from state to state. Service under this warranty must be obtained by following these steps, in order:

1. Contact your selling authorized Spirit Fitness dealer. OR
2. Contact your local authorized Spirit Fitness service organization.
3. If there is a question as to where to obtain service, contact our service department at (870) 935-1107.
4. Spirit Fitness' obligation under this warranty is limited to repairing or replacing, at Spirit Fitness' option, the product through one of our authorized service centers. All repairs must be preauthorized by Spirit Fitness. If the product is shipped to a service center freight charges to and from the service center will be the customer's responsibility. For replacement parts shipped while the product is under warranty, the customer will be responsible for shipping and handling charges. For in-home service, the customer will be responsible for a trip charge. There will be an additional trip charge if the customer is located over 100 miles from the nearest service center.
5. The owner is responsible for adequate packaging upon return to Spirit Fitness. Spirit Fitness is not responsible for damages in shipping. Make all freight damage claims with the appropriate freight carrier. DO NOT SHIP ANY UNIT TO OUR FACTORY WITHOUT A RETURN AUTHORIZATION NUMBER. All units arriving without a return authorization number will be refused.
6. For any further information, or to contact our service department by mail, send your correspondence to:

SPIRIT FITNESS, INC.
P.O. Box 2037
Jonesboro, AR 72402-2037

Product features or specifications as described or illustrated are subject to change without notice. All warranties are made by Spirit Manufacturing, Inc. This warranty applies only in the 48 contiguous United States. NOTE: This does not apply to Alaska or Hawaii.



800.258.4555
spiritservice@spiritfitness.com
www.spiritfitness.com



Spirit Fitness
3000 Nestle Road
Jonesboro, AR 72401



CT850ENT Owners Manual
© 2018 All Rights Reserved
Revision: 08.22.2018