

# ***SPIRIT***

---

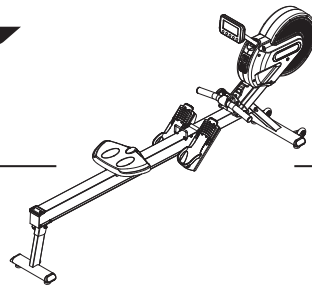

**XRW600** Rower  
OWNER'S MANUAL



# TABLE OF CONTENTS

5	IMPORTANT SAFETY INSTRUCTIONS
5	IMPORTANT ELECTRICAL INSTRUCTIONS
7	IMPORTANT OPERATION INSTRUCTIONS
7	PRODUCT REGISTRATION
8	XRW600 ASSEMBLY INSTRUCTIONS
14	CONSOLE OPERATION
19	PROGRAMMABLE FEATURES
34	USING HEART RATE TRANSMITTER
37	GENERAL MAINTENANCE
38	MANUFACTURER'S LIMITED WARRANTY

*Thank you for purchasing our product, please save these instructions. Please do not perform or attempt any customizing, adjustments, repair or maintenance that is not described in this manual.*

# ***SPIRIT***

Congratulations on your new Rower and welcome to the Spirit Fitness family!

Thank you for your purchase of this quality Rower from Spirit Fitness. Your new Rower was manufactured by one of the leading fitness manufacturers in the world and is backed by one of the most comprehensive warranties available. Through your dealer, Spirit Fitness will do all we can to make your ownership experience as pleasant as possible for many years to come. If not purchased direct from Spirit Fitness, the local dealership where you purchased this Rower is your administrator for all Spirit Fitness warranty and service needs. Their responsibility is to provide you with the technical knowledge and service personnel to make your experience more informed and any difficulties easier to remedy.

Please take a moment at this time to record the name of the dealer, their telephone number, and the date of purchase below to make any future, needed contact easy. We appreciate your support and we will always remember that you are the reason that we are in business.

Yours in Health,  
Spirit Fitness

NAME OF DEALER \_\_\_\_\_

DEALER PHONE # \_\_\_\_\_

PURCHASE DATE \_\_\_\_\_

*WARNING: This product may contain a chemical known to the state of California to cause cancer, birth defects, or other reproductive harm.*

## Important Safety Instructions

### WARNING

When using an electrical appliance, basic precautions should always be followed, including the following:

Read all instructions before using this appliance.

**DANGER** - To reduce the risk of electric shock:

Always unplug this appliance from the electrical outlet immediately after using and before cleaning.

**WARNING** - To reduce the risk of burns, fire, electric shock, or injury to persons, install the Rower on a flat level surface with access to a 110-volt, 15-amp grounded outlet with only the Rower plugged into the circuit.

DO NOT USE AN EXTENSION CORD UNLESS IT IS A 14AWG OR BETTER, WITH ONLY ONE OUTLET ON THE END:

- Do not operate Rower on deeply padded, plush or shag carpet. Damage to both carpet and Rower may result.
- Keep children away from the Rower. There are obvious pinch points and other caution areas that can cause harm.
- Keep hands away from all moving parts.
- Never operate the Rower if it has a damaged cord or plug. If the Rower is not working properly, call your dealer.
- Keep the cord away from heated surfaces.
- Do not operate where aerosol spray products are being used or where oxygen is being administered.

Sparks from the motor may ignite a highly gaseous environment.

- Never drop or insert any object into any openings.
- Do not use outdoors.
- To disconnect, turn all controls to the off position, then remove the plug from the outlet.
- Do not attempt to use your Rower for any purpose other than for the purpose it is intended.
- Use of a chest strap transmitter (sold separately) is an accurate method of heart rate analysis. Various factors, including the user's movement, may affect the accuracy of heart rate readings.
- Wear proper shoes. High heels, dress shoes, sandals or bare feet are not suitable for use on your Rower. Quality athletic shoes are recommended to avoid leg fatigue.
- This exercise equipment is not intended for use by persons with reduced physical, sensory or mental capabilities, or lack of experience and knowledge.
- Keep children under the age of 13 away from this machine.

**SAVE THESE INSTRUCTIONS - THINK SAFETY!**

## Important Electrical Instructions

### WARNING

**NEVER** remove any cover without first disconnecting AC power.

If voltage varies by ten percent (10%) or more, the performance of your Rower may be affected. Such conditions are not covered under your warranty. If you suspect the voltage is low, contact your local power company or a licensed electrician for proper testing. **NEVER** expose this Rower to rain or moisture. This product is NOT designed for use outdoors, near a pool or spa, or in any other high humidity environment. The operating temperature specification is 40 to 120 degrees Fahrenheit, and humidity is 95% non-condensing (no water drops forming on surfaces).

**Circuit Breakers:** Some circuit breakers used in homes are not rated for high inrush currents that can occur when a Rower is first turned on or even during use. If your Rower is tripping the house circuit breaker (even though it is the proper current rating) but the circuit breaker on the Rower itself does not trip, you will need to replace the home breaker with a high inrush type. This is not a warranty defect. This is a condition we as a manufacture have no ability to control. This part is available through most electrical supply stores. *Examples: Grainger part # 1D237, or available online at [www.squared.com](http://www.squared.com) part #QO120HM. The electrical outlet used should have a dedicated 15 amp circuit breaker.*

## Grounding Instructions

**This product must be grounded.** If the Rower should malfunction or breakdown, grounding provides a path of least resistance for electric current, reducing the risk of electric shock. This product is equipped with a cord having an equipment-grounding plug. The plug must be plugged into an appropriate outlet that is properly installed and grounded in accordance with all local codes and ordinances.

**DANGER** - Improper connection of the equipment-grounding conductor can result in a risk of electric shock. Check with a qualified electrician or serviceman if you are in doubt as to whether the product is properly grounded. Do not modify the plug provided with the product if it will not fit the outlet; have a proper outlet installed by a qualified electrician.

This product is for use on a nominal 110-volt/15 amp dedicated circuit, and has a grounding plug that looks like the plug illustrated below. A temporary adapter that looks like the adapter illustrated below may be used to connect this plug to a 2-pole receptacle as shown below if a properly grounded outlet is not available. The temporary adapter should be used only until a properly grounded outlet, (shown below) can be installed by a qualified electrician. The green colored rigid ear-lug, or the like, extending from the adapter, must be connected to a permanent ground such as a properly grounded outlet box cover. Whenever the adapter is used, it must be held in place by a metal screw.

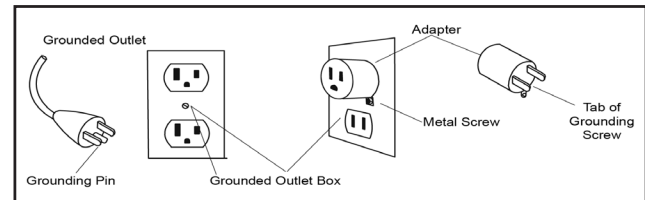

# Important Operation Instructions

- **NEVER** operate this Rower without reading and completely understanding the results of any operational change you request from the computer.
- Understand that changes in resistance do not occur immediately. Set your desired resistance level on the computer console and release the adjustment key. The computer will obey the command gradually.
- Use caution while participating in other activities while pedaling on your Rower; such as watching television, reading, etc. These distractions may cause you to lose balance which may result in serious injury.
- Do not use excessive pressure on console control keys. They are precision set to function properly with little finger pressure.

## Record Your Serial Number

Please record the serial number of this fitness product in the space provided below.

Serial Number:

## Register Your Purchase

The self-addressed product registration card must be completed in full and returned to Spirit Fitness. You can also go to <https://www.spiritfitness.com/residentialwarrantyregistration.html> under the Support tab to register online.

Serial Number Location

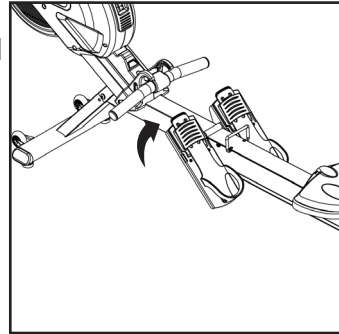

# XRW600 PRE ASSEMBLY

---

## UNPACKING

1. Cut the straps, then lift the box over the unit and unpack.
2. Carefully remove all parts from the carton and inspect for any damage or missing parts. If parts are damaged or missing, contact your dealer immediately.
3. Locate the hardware package. Remove the tools first. Remove the hardware for each step as needed to avoid confusion. The numbers in the instructions that are in parenthesis (#) are the item number from the assembly drawing for reference.

## TOOLS INCLUDED:

- 13/14mm Wrench
- Combination Wrench
- 4mm L Allen Wrench

## PARTS INCLUDED:

- 1 Main Frame
- 1 Aluminum Rail
- 1 Front Stabilizer
- 1 Rear Stabilizer
- 1 Console Mast
- 1 Console
- 2 Foot Pedals
- 1 Power Cord
- 1 Hardware Kit



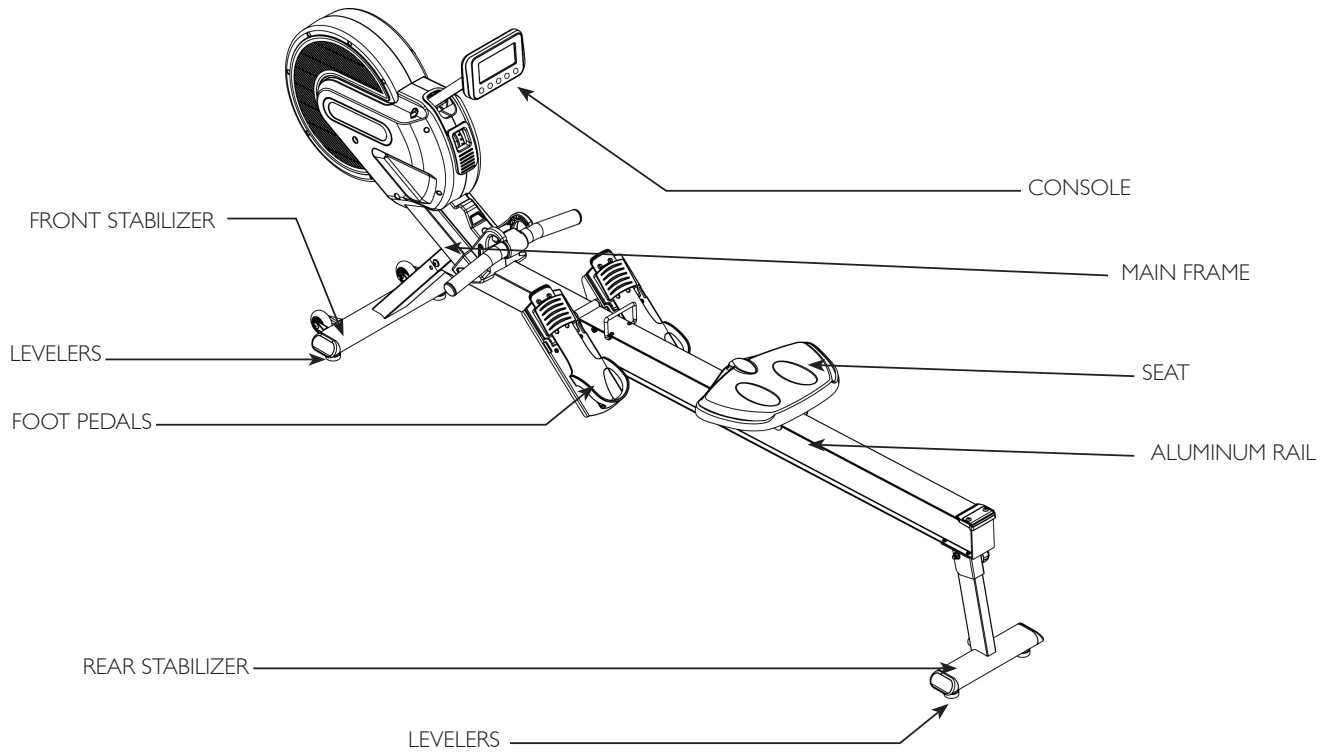

# XRW600 STEP ONE

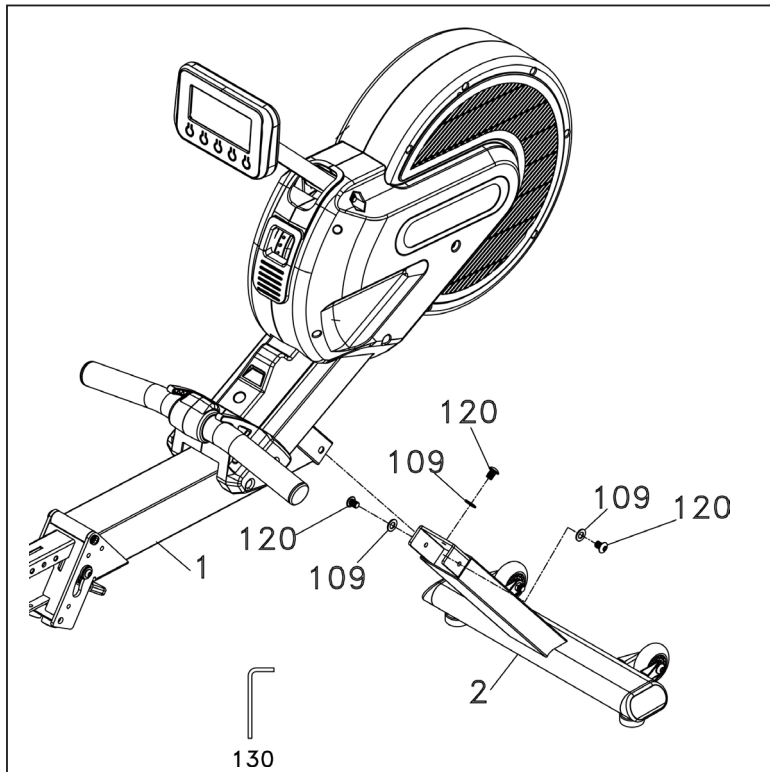

HARDWARE FOR STEP I			
PART	TYPE	DESCRIPTION	QTY
109	FLAT WASHER	3/8"X19X1.5T	3
120	BOLT	3/8"X3/4"	3

1. Gather **HARDWARE FOR STEP I**.
2. Use the **WRENCH (130)** to tighten 3 **BUTTON HEAD SOCKET BOLTS (120)** together with 3 **FLAT WASHERS (109)** to secure the **MAIN FRAME (1)** and **FRONT STABILIZER (2)** together.

# XRW600 STEP TWO

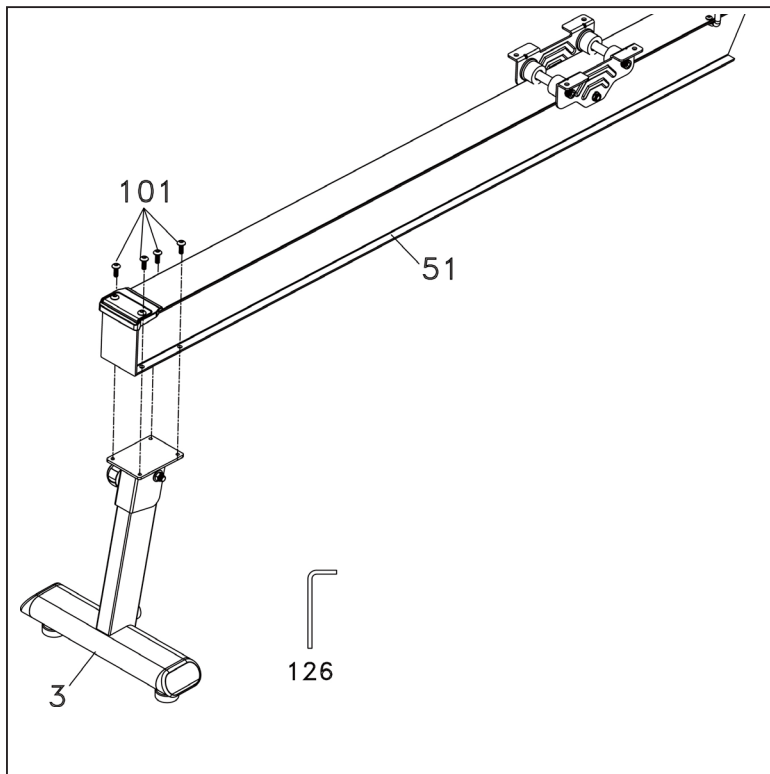

HARDWARE FOR STEP 2			
PART	TYPE	DESCRIPTION	QTY
101	BOLT	M6X10mm	4

1. Gather **HARDWARE FOR STEP 2**.
2. Use **ALLEN WRENCH (126)** to tighten 4 **BUTTON HEAD SOCKET BOLTS (101)** through the **ALUMINUM TRACK (51)** then secure the **ALUMINUM TRACK (51)** and the **REAR STABILIZER (3)** together.

# XRW600 STEP THREE

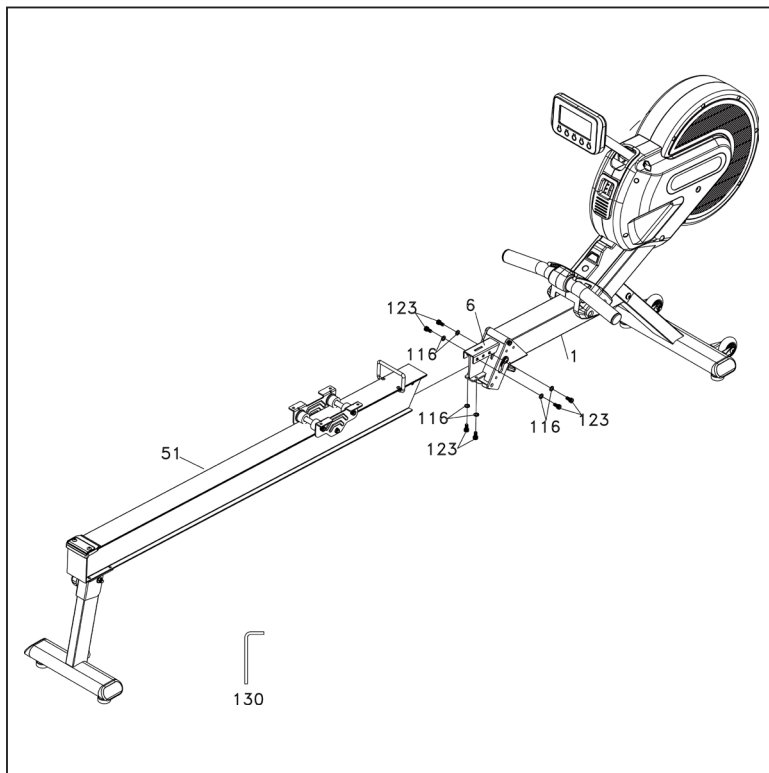

HARDWARE FOR STEP 3			
PART	TYPE	DESCRIPTION	QTY
116	SPLIT WASHER	8X1.5T	6
123	BOLT	M8X15mm	6

1. Gather **HARDWARE FOR STEP 3**.
2. Attach the other end of the **ALUMINUM TRACK (51)** to **FOLDING END ASSEMBLY (6)** of the Main Frame (1) and use **ALLEN WRENCH (130)** to tighten the 6 **SOCKET HEAD CAP BOLTS (123)** together with 6 **SPLIT WASHERS (116)**.

# XRW600 STEP FOUR

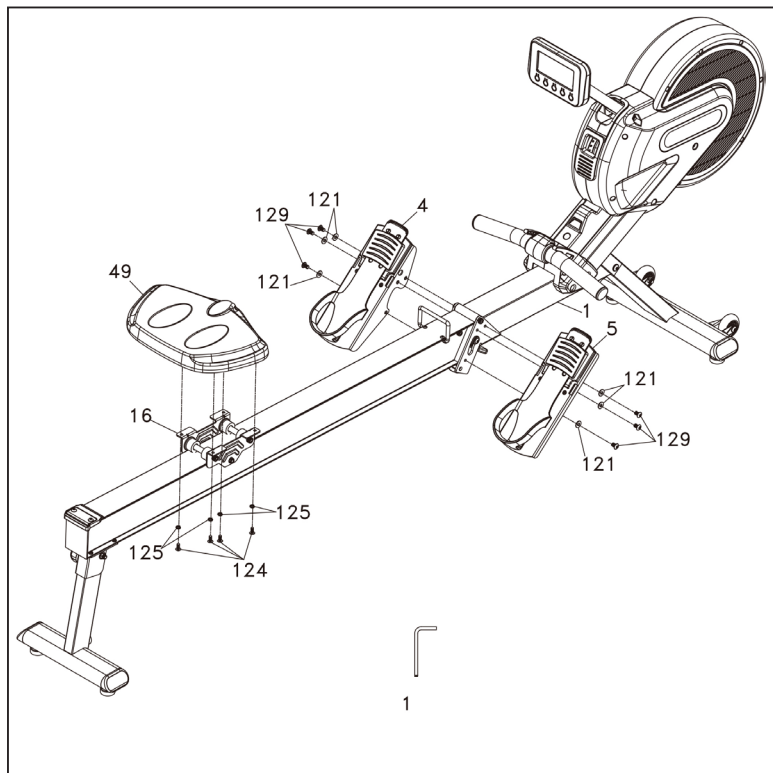

HARDWARE FOR STEP 4			
PART	TYPE	DESCRIPTION	QTY
121	Flat Washer	5/16" x Ø18 x 1.5T	6
124	Phillips Head Screw	M6 x 15L	4
125	Spring Washer	Ø1/4"	4
129	Button Head Socket Bolt	M8 x 12L	6

1. Gather **HARDWARE FOR STEP 4**.
2. Use Combination **M5 ALLEN WRENCH & PHILLIPS HEAD SCREW DRIVER (127)** to tighten 6 **BUTTON HEAD SOCKET BOLT(129)** and 6 **FLAT WASHERS(121)** to install then **LEFT AND RIGHT PEDALS(4,5)** on the **MAIN FRAME(1)**. Use again **COMBINATION M5 ALLEN WRENCH & PHILLIPS HEAD SCREW DRIVER (127)** to tighten 4 **PHILLIPS HEAD SCREW(124)** together with 4 **SPLIT WASHERS(125)** to install **SEAT(49)** onto the **SEAT ATTACHING BOARD (16)**.

# XRW600 CONSOLE OPERATION

---



## Power

When Pressing any key button wakes up the console which has been turned off, the console LCD will turn on with full display and beeps for 2 seconds then enters idle mode. When there is speed signal input with the speed sensor detected, it directly enters Manual workout mode.

**Power off:** In any mode during turning on, if there is not any button activated or no rowing activity lasts for 1 minute, it turns off automatically.

## Window Functions

### Stroke/min

- S/M value shows the equivalent strokes per minute.

### Time

- It shows the time.
- Range of time: 00:00~99:59(minute: second)
- The time is accumulated for each workout mode.
- When time is set to count down, it shows the time remaining.

### Distance

- The distance range is 0~9999 and switches to the format of 1X.XX when the value is over 9999.
- The distance will be accumulated for each workout mode.
- When the distance is set to count down, it shows the remaining distance.

## Heart Rate

- The heart rate range is 40~220 bpm
- When the heart rate signal is detected, the small dot at lower right corner of the heart rate window will be blinking together with heart rate value showing.
- When there is no heart rate signal detected, the heart rate window shows nothing.

## Calories

- The calorie window shows the value of calories burned .
- The calorie range is 0~999.
- The calorie value is based on built in estimates of the average user and may not reflect accuracy.To have a more accurate basis of caloric burn - please contact your physician and they can assist you.

## Watts

- The Watts window shows Watt value for each stroke.
- The Watt range is 0 ~ 2000.
- When the numbers show over 999 (four digits), the display uses a decimal to show in thousands. E.g. 1000 shows as 1.00, 1240 reads as 1.24, 1250 as 1.25, 2000 as 2.00, etc.

## Level

- The level window shows the current resistance level.
- The level range is 1~16
- Level 1 and 2 would light the first dot, level 3 and 4 would light the second dot, etc.



## 500M/Time

- Only workout modes of Manual, Distance, Time and Calorie are with this display function.
- For Manual workout mode as an example: When the console starts, Matrix in the middle of LCD will show the wave pattern then switch to **500M/TIME 00:00** across center display after 5 seconds then switch again back to the wave pattern after another 5 seconds and continue to repeat the cycle. This is the function of **SCAN**.
- The console goes directly into **SCAN** mode after start. If **MODE** button is pressed, it shows the wave pattern. Pressing the **MODE** button again, it displays 500M/TIME and repeat again by pressing "MODE" button it goes back with "SCAN" function (recyclable).

## Key button Function

- Any valid key button pressed will generate a beep sound.
- When in power off mode, pressing any key button turns on the console.

## Mode Key

- Under idle mode, pressing **MODE** key each time switches the workout mode with the following sequence:
- **MANUAL » DISTANCE » TIME » CALORIES » 20/10 INTERVAL » 10/20 INTERVAL » CUSTOM INTERVAL » Fat Burn » Cardio » Strength » Game**
- The default workout mode after turning on the unit is Manual mode.
- To choose the target workout mode, when the matrix window shows the desired workout pattern and parameter window value to be set will be blinking each second.

## Up Key

- Under the setting mode of the target workout, the parameter is will be counted up.

- The value increases one increment when **UP** key is pressed once.

## Down Key

- Under the setting mode of the target workout, the parameter is will be counted down.
- The value decreases one increment when **DOWN** key is pressed once.

## Start/Stop Key

- Under idle mode, pressing **Start/Stop** key button enters Manual workout mode.
- To confirm the value the window is showing when setting the parameter under each target workout mode and to start the workout mode.
- Press to end the current workout mode and all message windows stop counting.

## Reset Key

- Pressing this key button under stopping mode, the image switches to the idle mode.
- The reset key button is valid only in stopping mode.
- Under any mode, pressing this key button for 3 seconds turns on the console again.

# Operating Instruction

The screen is with full display and the buzzer beeps for two seconds after turning on. Pressing **Start** button goes directly to **Manual** workout mode or pressing **MODE** button to switch and select a workout mode with the workout sequence shown as below:

**MANUAL » DISTANCE » TIME » CALORIES » 20/10 INTERVAL » 10/20 INTERVAL » CUSTOM INTERVAL » Fat Burn » Cardio » Strength » Game**

The program name will scroll from left to right to tell the user what it is.

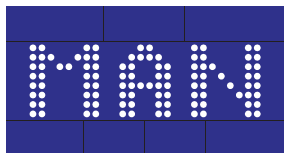

Manual



Distance



Time



Calories



20/10 Interval



10/20 Interval



Custom Interval

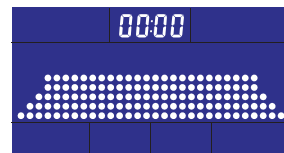

Fat Burn

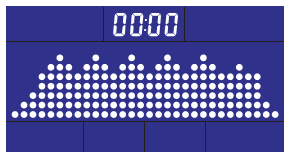

Cardio

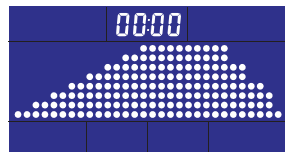

Strength

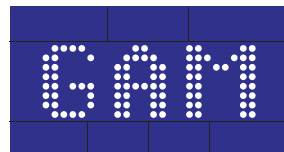

Game

# Manual Mode

## To choose MANUAL mode (Fig. I-1)

Pressing **Start/Stop** button begins the workout mode or pulling the handlebar under the idle mode enters directly into Manual workout mode.

The image at the center of LCD will scan every 5 seconds to show the stroke speed with wave pattern (Fig. I-2) and 500M/TIME (Fig. I-3) or pressing **MODE** button to cancel scanning with wave pattern only. Pressing **MODE** again switches the image to show **500M/TIME**.

Pressing **UP** or **DOWN** button and adjusts the resistance level which is shown at bottom right corner of **LEVEL** window.

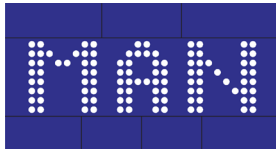

Fig I-1



Fig I-2

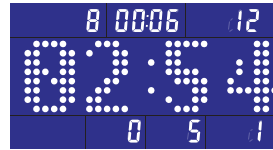

Fig I-3

## Target Distance

### To choose target distance count-down Distance workout mode (Fig. 2-1)

Use **UP/DOWN** buttons to adjust and set the workout distance. The default distance is 100M with increment of 50M up or down. Press **Start/Stop** button to confirm the setting and start the workout mode.

The image at the center of LCD will scan every 5 seconds to show the stroke speed with wave pattern (**Fig. 2-2**) and 500M/TIME (**Fig. 2-3**) or pressing **MODE** button to cancel scanning with wave pattern only. Pressing **MODE** again switches the image to show **500M/TIME**.

**Distance** window counts down from target distance setting value and shows the remaining distance of the workout.

Under the workout mode, pressing **UP** or **DOWN** key button adjusts the resistance level.

When the distance is counted down to 0, the workout completes and the buzzer sounds with a long beep. If rowing continues, the distance count-down repeats.



Fig 2-1



Fig 2-2



Fig 2-3

## Target Time

### To choose target time count-down Time workout mode (Fig. 3-1)

Use **UP/DOWN** buttons to adjust and set the workout time. The default distance is 1:00 with 1-minute increment of up or down (99:00 maximum). Press **Start/Stop** button to confirm the setting and start the workout mode.

The image at the center of LCD will scan every 5 seconds to show the stroke speed with wave pattern (**Fig. 3-2**) and 500M/TIME (**Fig. 3-3**) or pressing **MODE** button to cancel scanning with wave pattern only. Pressing **MODE** again switches the image to show 500M/TIME.

Under the workout mode, pressing **UP** or **DOWN** key button adjusts the resistance level.

Time window counts down from the setting time value and shows the remaining time of the workout.

When time is counted down to 0:00, the workout completes and the buzzer sounds with a long beep. If rowing continues, the time count-down repeats.



Fig 3-1



Fig 3-2

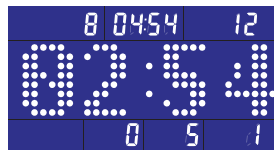

Fig 3-3

## Target Calorie

To choose target calorie count-down Calories workout mode (**Fig. 4-1**)

Use **UP/DOWN** buttons to adjust and set the target calorie. The default value is 100 with increment of 10 up or down. Press **Start/Stop** button to confirm the setting and start the workout mode.

The image at the center of LCD will scan every 5 seconds to show the stroke speed with wave pattern (**Fig. 4-2**) and 500M/TIME (**Fig. 4-3**) or pressing **MODE** button to cancel scanning with wave pattern only. Pressing **MODE** again switches the image to show **500M/TIME**.

Calorie window counts down from the setting target calorie value and shows the remaining calorie of the workout.

Under the workout mode, pressing **UP** or **DOWN** key button adjusts the resistance level.

When calorie is counted down to 0, the workout completes and the buzzer sounds with a long beep. If rowing continues, the time count-down repeats.



Fig 4-1



Fig 4-2



Fig 4-3

## 20/10 Interval

### To choose 20/10 INTERVAL workout mode (Fig. 5-1)

The image at the center of LCD: 20 seconds (Exercise)/10 seconds (Rest)

Pressing **Start/Stop** button starts the workout mode.

The image at the center of LCD shows time count-down of current workout and wave (Fig. 5-2) or rest time count-down and mark (Fig. 5-3).

Under the workout mode, pressing **UP** or **DOWN** key button adjusts the resistance level.

There are 10 Exercise/Rest cycles for each workout time.

When workout completes, the buzzer sounds with a long beep. If rowing continues, the time count-down repeats.



Fig 5-1



Fig 5-2



Fig 5-3



# 10/20 Interval

## To choose 10/20 INTERVAL workout mode (Fig. 6-1)

The image at the center of LCD: 10 seconds (Exercise)/20 seconds (Rest)

Pressing **Start/Stop** button starts the workout mode.

The image at the center of LCD shows time count-down of current workout and wave (Fig. 6-2) or rest time count-down and mark (Fig. 6-3).

Under the workout mode, pressing **UP** or **DOWN** key button adjusts the resistance level.

There are 10 Exercise/Rest cycles for each workout time.

When workout completes, the buzzer sounds with a long beep. If rowing continues, the time count-down repeats.



Fig 6-1

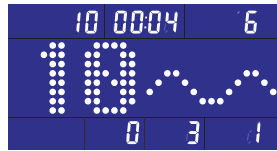

Fig 6-2

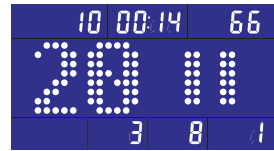

Fig 6-3

# Custom Interval

## To choose CUSTOM INTERVAL workout mode (Fig. 7-1)

User-define time (Exercise)/time (Rest): the default is 10 seconds (Exercise)/10 seconds (Rest)

The value at left side of the matrix window flashes for setting the exercise time. Use **UP/DOWN** buttons to adjust and set the workout time. The default time is 10 seconds with 1-second increment of up or down. Press **Start/Stop** button to confirm the setting and start the workout mode.

The value at right side of the matrix window flashes for setting the rest time. Use **UP/DOWN** buttons to adjust and set the workout time. The default time is 10 seconds with 1-second increment of up or down. Press **Start/Stop** button to confirm the setting and start the workout mode.

The image at the center of LCD: 10 seconds (Exercise)/10 seconds (Rest)

Pressing **Start/Stop** button starts the workout mode.

The image at the center of LCD shows time count-down of current workout and wave (**Fig. 7-2**) or rest time count-down and mark (**Fig. 7-3**).



Fig 7-1



Fig 7-2



Fig 7-3

Under the workout mode, pressing **UP** or **DOWN** key button adjusts the resistance level.

There are 10 Exercise/Rest cycles for each workout time.

When workout completes, the buzzer sounds with a long beep. If rowing continues, the time count-down repeats.

## Fat Burn

### To choose Fat Burn workout mode (Fig. 8-1)

Pressing **Start/Stop** button and begins the workout mode or setting the workout time. Use **UP/DOWN** buttons to adjust the time. The increment of adjustment is 5-minute (99:00 maximum). Press **Start/Stop** button to start the workout mode.

The image at the center of LCD shows the fat burn profile (**Fig. 8-2**)

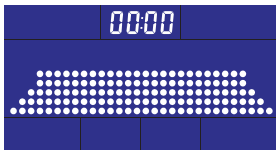

Fig 8-1

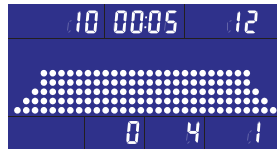

Fig 8-2

Under the workout mode, pressing **UP** or **DOWN** key button adjusts the resistance level.

Time window starts count-down from the setting time and shows the remaining workout time.

When time is counted down to 0:00, the workout completes and the buzzer sounds with a long beep. If rowing continues, the time count-down repeats.

## Cardio Workout

### To choose cardio workout mode (Fig. 9-1)

Pressing **Start/Stop** button and begins the workout mode or setting the workout time. Use **UP/ DOWN** buttons to adjust the time. The increment of adjustment is 5-minute (99:00 maximum). Press **Start/Stop** button to start the workout mode.

The image at the center of LCD shows the cardio profile (Fig. 9-2)

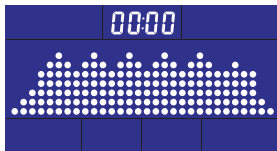

Fig 9-1

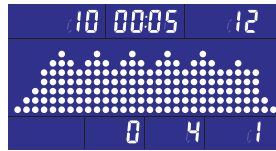

Fig 9-2

Under the workout mode, pressing **UP** or **DOWN** key button adjusts the resistance level.

Time window starts count-down from the setting time and shows the remaining workout time.

When time is counted down to 0:00, the workout completes and the buzzer sounds with a long beep. If rowing continues, the time count-down repeats.

## Strength Workout

### To choose Strength workout mode (Fig. 10-1)

Pressing **Start/Stop** button and begins the workout mode or setting the workout time. Use **UP/ DOWN** buttons to adjust the time. The increment of adjustment is 5-minute (99:00 maximum). Press **Start/Stop** button to start the workout mode.

The image at the center of LCD shows the strength profile (**Fig. 10-2**)

Time window starts count-down from the setting time and shows the remaining workout time.

When time is counted down to 0:00, the workout completes and the buzzer sounds with a long beep. If rowing continues, the time count-down repeats.

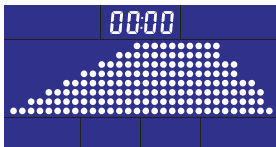

Fig 10-1

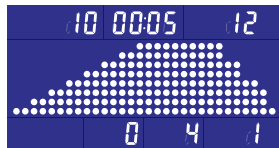

Fig 10-2

# Game Workout

## To choose GAME workout mode (Fig. 11-1)

Pressing **Start/Stop** button and begins the **GAME** workout mode (11-2).

The goal of the Game Workout Mode is the manoeuvre your user dots through an obstacle field by rowing faster or slower to raise/lower the use dot sprite.

Three dots at left side represents the user position and the image shift one profile left per second and continue to scroll.

The position of the user will not shift. However, the faster the user rows, the higher the user's position. When there is no input, the position of the user goes down to the lowest. The height of the user's position is equivalent to the speed the user strokes.

The time for the game workout starts counting down from 5 minutes and ends when time is up.

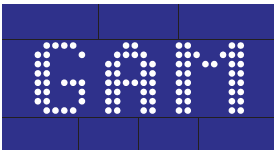
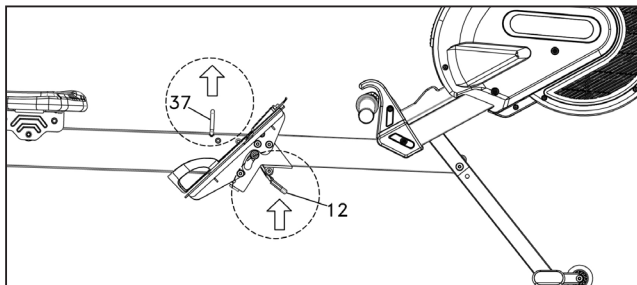

Fig 11-1

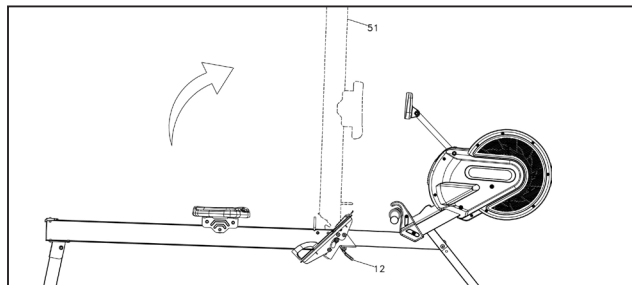

Fig 11-2

## Folding/Unfolding Procedures



1. Hold the Handlebar (37) to lift the rower slightly and press the Release Lever (12).



2. Lift and fold the Aluminum Track until it locks into place.

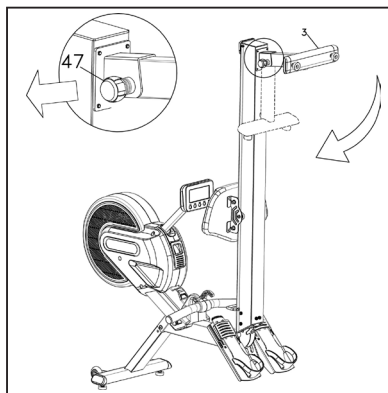

3. To fold Rear Stabilizer; turn Knob (47) counterclockwise until loosened. Pull Knob to release and fold Rear Stabilizer.
4. To unfold Rower, reverse steps.

## Moving Procedures

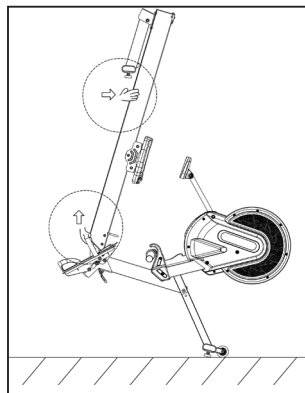

1. Fold the aluminum rail assembly up.
2. Lift the rear and roll away.

# Heart Rate Monitoring (chest strap not included)

The old motto, “no pain, no gain”, is a myth that has been overpowered by the benefits of exercising comfortably. A great deal of this success has been promoted by the use of heart rate monitors. With the proper use of a heart rate monitor, many people find that their usual choice of exercise intensity was either too high or too low and exercise is much more enjoyable by maintaining their heart rate in the desired benefit range.

To determine the benefit range in which you wish to train, you must first determine your Maximum Heart Rate. This can be accomplished by using the following formula: 220 minus your age. This will give you the Maximum Heart Rate (MHR) for someone of your age. To determine the effective heart rate range for specific goals you simply calculate a percentage of your MHR. Your Heart rate training zone is 50% to 90% of your maximum heart rate. 60% of your MHR is the recommended for burning fat while 80% is recommended for strengthening the cardio vascular system. This 60% to 80% is the zone to stay in for maximum benefit.

For someone who is 40 years old their target heart rate zone is calculated:  
 $220 - 40 = 180$  (maximum heart rate)  
 $180 \times .6 = 108$  beats per minute (60% of maximum)  
 $180 \times .8 = 144$  beats per minute (80% of maximum)  
So for a 40 year old the training zone would be 108 to 144 beats per minute.

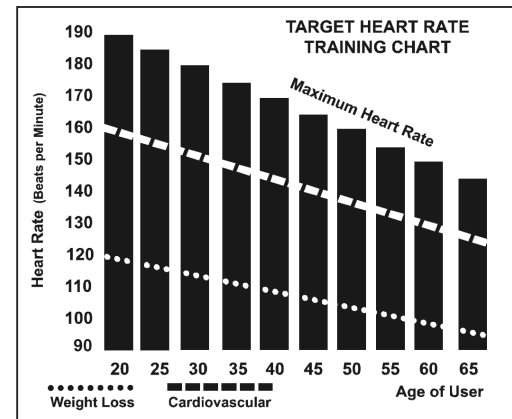



The two most popular reasons for, or goals, of exercise are cardiovascular fitness (training for the heart and lungs) and weight control. The black columns on the chart above represent the MHR for a person whose age is listed at the bottom of each column. The training heart rate, for either cardiovascular fitness or weight loss, is represented by two different lines that cut diagonally through the chart. A definition of the lines' goal is in the bottom left-hand corner of the chart. If your goal is cardiovascular fitness or if it is weight loss, it can be achieved by training at 80% or 60%, respectively, of your MHR on a schedule approved by your physician. Consult your physician before participating in any exercise program.

# Rate of Perceived Exertion

Heart rate is important but listening to your body also has a lot of advantages. There are more variables involved in how hard you should workout than just heart rate. Your stress level, physical health, emotional health, temperature, humidity, the time of day, the last time you ate and what you ate, all contribute to the intensity at which you should workout. If you listen to your body, it will tell you all of these things.

The rate of perceived exertion (RPE), also known as the Borg scale, was developed by Swedish physiologist G.A.V. Borg. This scale rates exercise intensity from 6 to 20 depending upon how you feel or the perception of your effort.

The scale is as follows:

## Rating Perception of Effort

6 Minimal	10 Very light +	14 Somewhat hard +	18 Very hard +
7 Very, very light	11 Fairly light	15 Hard	19 Very, very hard
8 Very, very light +	12 Comfortable	16 Hard +	20 Maximal
9 Very light	13 Somewhat hard	17 Very hard	

You can get an approximate heart rate level for each rating by simply adding a zero to each rating. For example a rating of 12 will result in an approximate heart rate of 120 beats per minute. Your RPE will vary depending upon the factors discussed earlier. That is the major benefit of this type of training. If your body is strong and rested, you will feel strong and your pace will feel easier. When your body is in this condition, you are able to train harder and the RPE will support this. If you are feeling tired and sluggish, it is because your body needs a break. In this condition, your pace will feel harder. Again, this will show up in your RPE and you will train at the proper level for that day.

## Wearing The Chest Strap *\*Not Included*

1. Attach the transmitter to the elastic strap using the interlocking key.
2. Adjust the strap as tightly as possible as long as the strap is not too tight to remain comfortable.
3. Position the transmitter with the logo centered in the middle of your torso facing away from your chest (some people must position the transmitter slightly left of center). Attach the final end of the elastic strap by inserting the round end and, using the locking parts, secure the transmitter and strap around your chest.
4. Position the transmitter directly below the pectoral muscles.
5. Sweat is the best conductor to measure very minute heart beat electrical signals. However, plain water can also be used to pre-wet the electrodes (2 ribbed oval areas on the reverse side of the belt and both sides of the transmitter). It's also recommended that you wear the transmitter strap a few minutes before your work out. Some users, because of body chemistry, have a more difficult time in achieving a strong, steady signal at the beginning. After “warming up”, this problem lessens.
6. Your workout must be within range - distance between transmitter/receiver – to achieve a strong steady signal. The length of range may vary somewhat but generally stay close enough to the console to maintain good, strong, reliable readings. Wearing the transmitter directly on bare skin assures you of proper operation. If you wish, you may wear the transmitter over a shirt. To do so, wet the areas of the shirt that the electrodes will rest upon.

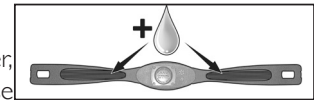
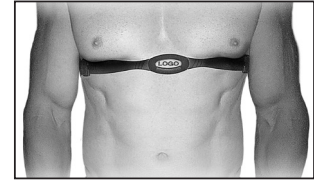

**Note:** *The transmitter is automatically activated when it detects activity from the user's heart. Additionally, it automatically deactivates when it does not receive any activity. Although the transmitter is water resistant, moisture can have the effect of creating false signals, so you should take precautions to completely dry the transmitter after use to prolong battery life (estimated transmitter battery life is 2500 hours). The replacement battery is Panasonic CR2032.*

## Erratic Operation

Caution! Do not use this Rower for Heart Rate monitoring unless a steady, solid Actual Heart Rate value is being displayed. High, wild, random numbers being displayed indicate a problem.

Areas to look for interference which may cause erratic heart rate:

1. Microwave ovens, TV's, small appliances, etc.
2. Fluorescent lights.
3. Some household security systems.
4. Perimeter fence for a pet.
5. Some people have problems with the transmitter picking up a signal from their skin. If you have problems try wearing the transmitter upside down. Normally the transmitter will be oriented so the Spirit Fitness logo is right side up.
6. The antenna that picks up your heart rate is very sensitive. If there is an outside noise source, turning the whole machine 90 degrees may de-tune the interference.
7. Another Individual wearing a transmitter within 3' of your machine's console.

If you continue to experience problems contact your dealer:

# GENERAL MAINTENANCE

1. Wipe down all areas in the sweat path with a damp cloth after each workout.
2. If a squeak, thump, clicking or rough feeling develops the main cause is most likely one of three reasons:
  - I. The hardware was not sufficiently tightened during assembly. All bolts that were installed during assembly need to be tightened as much as possible. It may be necessary to use a larger wrench than the one provided if you cannot tighten the bolts sufficiently. I cannot stress this point enough; 90% of calls to the service department for noise issues can be traced to loose hardware.
  - II. The crank arm nut needs to be retightened.
  - III. If squeaks or other noises persist, check that the unit is properly leveled. There are 2 leveling pads on the bottom of the rear stabilizer; use a 14mm wrench (or adjustable wrench) to adjust the levelers.

# Rower Warranty - Effective May 4, 2018

Spirit Fitness, Inc. (Spirit Fitness) warrants all its Rower parts for a period of time listed below from the date of retail sale, as determined by sale receipt, or in the absence of a sales receipt eighteen (18) months from the original factory shipping date. Spirit Fitness' responsibilities include providing new or remanufactured parts, at Spirit Fitness' option, and technical support to our independent dealers and servicing organizations. In the absence of a dealer or service organization, these warranties will be administered by Spirit Fitness directly to a consumer. The warranty period applies to the following components:

<b>Warranty</b>	<b>Frame</b>	<b>Brake</b>	<b>Parts</b>	<b>Labor</b>
<b>Residential</b>	<b>Lifetime</b>	<b>Lifetime</b>	<b>10 Years</b>	<b>1 Year</b>

## NORMAL RESPONSIBILITIES OF THE CONSUMER

This warranty applies only to products in ordinary household or Light Commercial use (see restrictions above), and the consumer/facility is responsible for the items listed below:

1. The warranty registration card must be completed and returned to the address listed on the card within 10 days of the original purchase to validate the manufacturer's limited warranty.
2. Proper use of the Rower in accordance with the instructions provided in this manual
3. Proper installation in accordance with instructions provided with the Rower and with all local electric codes.
4. Expenses for making the Rower accessible for servicing, including any item that was not part of the Rower at the time it was shipped from the factory.
5. Damages to the Rower finish during shipping, installation or following installation.
6. Routine maintenance of this unit as specified in this manual.

## EXCLUSIONS

This warranty does not cover the following:

1. CONSEQUENTIAL, COLLATERAL, OR INCIDENTAL DAMAGES SUCH AS PROPERTY DAMAGE AND INCIDENTAL EXPENSES RESULTING FROM ANY BREACH OF THIS WRITTEN OR ANY IMPLIED WARRANTY.  
Note: Some states do not allow the exclusion or limitation of incidental or consequential damages, so this limitation or exclusion may not apply to you.
2. Service call reimbursement to the consumer: Service call reimbursement to the dealer that does not involve malfunction or defects in workmanship or material, for units that are beyond the warranty period, for units that are beyond the service call reimbursement period, for Rower not requiring component replacement, or Rower not in ordinary household or light commercial use.
3. Damages caused by services performed by persons other than authorized Spirit Fitness service companies; use of parts other than original Spirit Fitness parts; or external causes such as corrosion, discoloration of paint or plastic, alterations, modifications, abuse, misuse, accident, improper maintenance, inadequate power supply, or acts of God.
4. Products with original serial numbers that have been removed or altered.

5. Products that have been: sold, transferred, bartered, or given to a third party.
6. Products that do not have a warranty registration card on file at Spirit Fitness. Spirit Fitness reserves the right to request proof of purchase if no warranty record exists for the product.
7. THIS WARRANTY IS EXPRESSLY IN LIEU OF ALL OTHER WARRANTIES EXPRESSED OR IMPLIED, INCLUDING THE WARRANTIES OF MERCHANTABILITY AND/OR FITNESS FOR A PARTICULAR PURPOSE.
8. Product use in any environment other than a residential setting or non-dues paying facility with 5 hours use or less per day.
9. Warranties outside of the United States may vary. Please contact your local dealer for details.

#### SERVICE

Keep your bill of sale. Twelve (12) months from the date on the bill of sale or eighteen (18) months from the date of factory shipping as determined by the serial number establishes the labor warranty period should service be required. If service is performed, it is in your best interest to obtain and keep all receipts. This written warranty gives you specific legal rights. You may also have other rights that vary from state to state. Service under this warranty must be obtained by following these steps, in order:

1. Contact your selling authorized Spirit Fitness dealer. OR
2. Contact your local authorized Spirit Fitness service organization.
3. If there is a question as to where to obtain service, contact our service department at (870) 935-1107.
4. Spirit Fitness' obligation under this warranty is limited to repairing or replacing, at Spirit Fitness' option, the product through one of our authorized service centers. All repairs must be preauthorized by Spirit Fitness. If the product is shipped to a service center freight charges to and from the service center will be the customer's responsibility. For replacement parts shipped while the product is under warranty, the customer will be responsible for shipping and handling charges. For in-home service, the customer will be responsible for a trip charge. There will be an additional trip charge if the customer is located over 100 miles from the nearest service center.
5. The owner is responsible for adequate packaging upon return to Spirit Fitness. Spirit Fitness is not responsible for damages in shipping. Make all freight damage claims with the appropriate freight carrier: DO NOT SHIP ANY UNIT TO OUR FACTORY WITHOUT A RETURN AUTHORIZATION NUMBER. All units arriving without a return authorization number will be refused.
6. For any further information, or to contact our service department by mail, send your correspondence to:

Spirit Fitness, Inc.  
P.O. Box 2037  
Jonesboro, AR 72402-2037

Product features or specifications as described or illustrated are subject to change without notice. All warranties are made by Spirit Fitness, Inc. This warranty applies only in the 48 contiguous United States. NOTE: This does not apply to Alaska or Hawaii.



800.258.4555  
spiritservice@spiritfitness.com  
www.spiritfitness.com



Spirit Fitness  
3000 Nestle Road  
Jonesboro, AR 72401

***SPIRIT***

XRW600 Owners Manual  
© 2018 All Rights Reserved  
Revision 4: 05.04.2018