



TUFFSTUFF FITNESS INTERNATIONAL

OWNER'S MANUAL

Maintenance & Assembly Instructions

IMPORTANT: KEEP THIS MANUAL FOR FUTURE REFERENCE

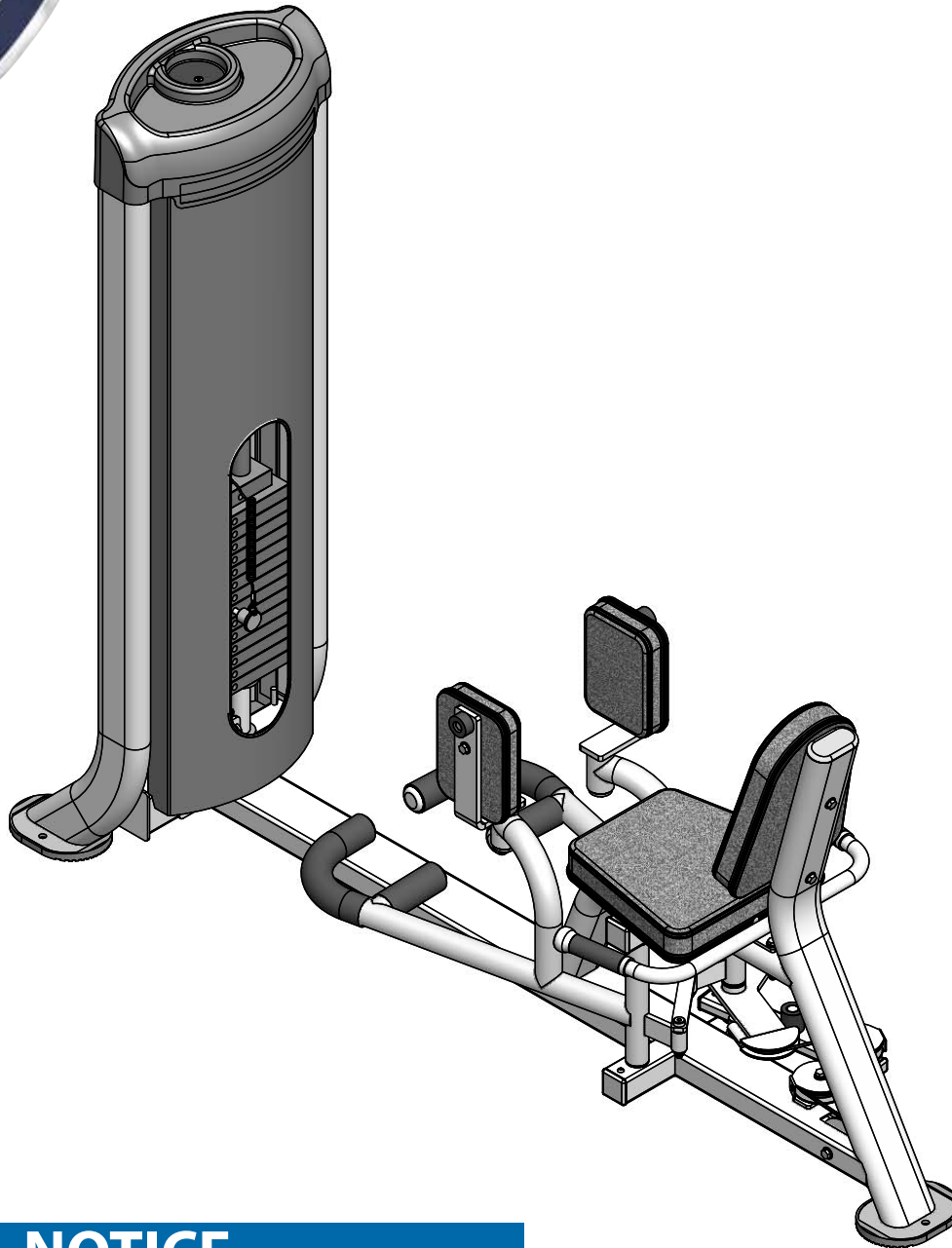

NOTICE

It is the Purchaser's/Owner's obligation:

1. To disclose and post all Rules & Regulations, Danger, Warning and Caution labels affixed on the machine to their customers/users.
2. Equipment to be installed by TFI Authorized Dealer or a service company approved by TFI.
3. Provide trained personnel, supervision and correct usage of the equipment.
4. Provide scheduled inspection, maintenance & repairs and must be performed by TFI Authorized Dealer or a service company approved by TFI.
5. Must use only genuine TFI replacement parts.
6. **▲ WARNING** Machine must be anchored to a solid and level surface.

CG-9515

Inner/Outer Thigh

Table of Contents



Overhead Specifications.....	Page 3
Danger, Warning, & Caution Labels Information	Page 4-7
Anchoring Unit.....	Page 8
Important Safety Instructions.....	Page 9
Registration, Service & Assembly	Page 10
Inspection/Maintenance	Page 11
Cable Inspection.....	Page 12
Step 1	Page 13
Step 2.....	Page 14
Step 3.....	Page 15
Step 4.....	Page 16-17
Step 5 Cable Routing	Page 18-19
Step 6 Cable Routing	Page 20-21
Step 7	Page 22
Step 8.....	Page 23
Parts List.....	Page 24
Pre-Assembled Components	Page 25-26
Notes.....	Page 27
Warranty	Page 28

TuffStuff Fitness International Inc. continually engages in research related to product improvements. Please take the time to carefully read through this owner's manual thoroughly. Instructions contained in this owner's manual are not intended to cover all details or variations possible with equipment, or to cover every contingency that may be met in conjunction with assembly, installation, operation, maintenance or troubleshooting of the equipment. Even though we have prepared this owner's manual with extreme care, neither the manufacturer nor the author can accept responsibility for any errors in, or omission from, the information given. Should additional information be required, or should situations arise that are not covered by this owner's manual, the matter should be directed to Customer Service at TuffStuff Fitness International Inc. in Chino, California.

Overhead Specifications

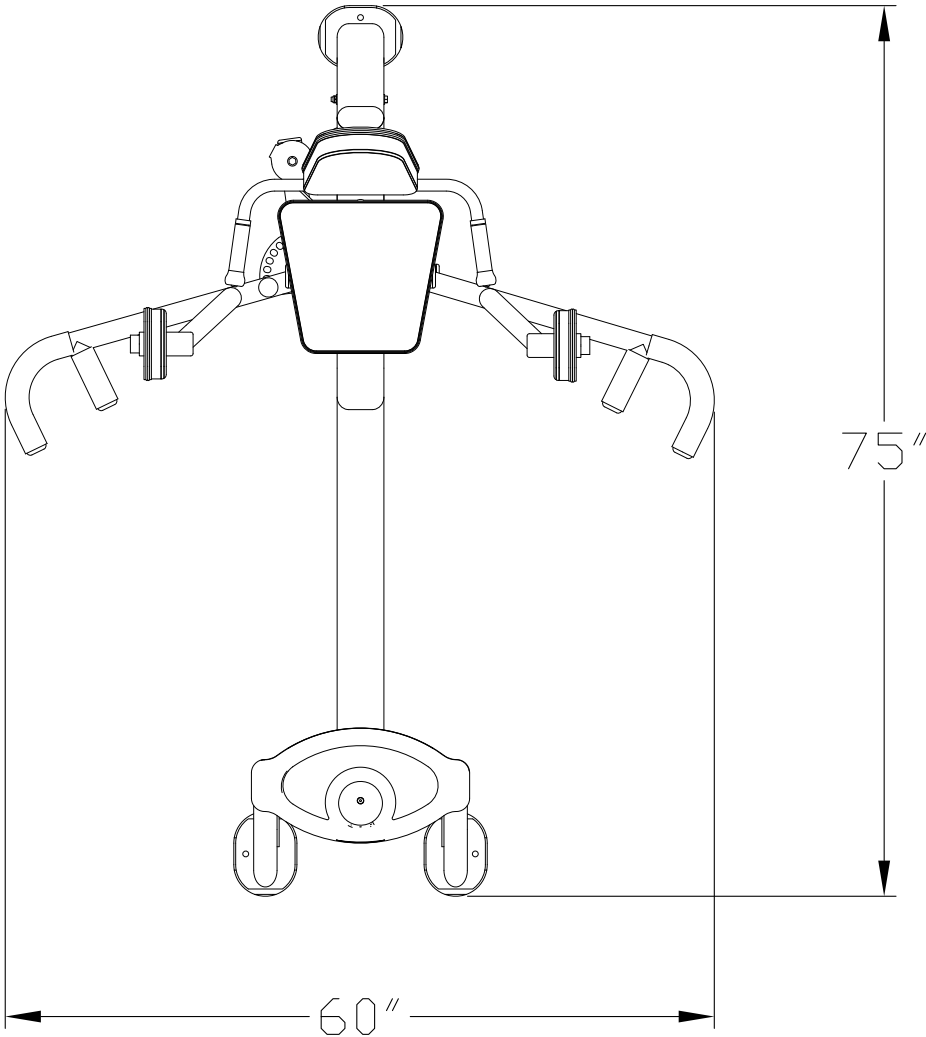

L 75" X W 60" X H 59"
MAX-LOAD WEIGHT LIMIT -150 lbs

Carefully read ALL Danger, Warning & Caution labels posted on the machine

93

WARNING

Serious injury or death can occur if these rules and precautions are not observed:

1. Read and Understand Owner's Manual and all DANGER, WARNING and CAUTION labels before using this equipment. If you still need help, seek assistance from floor personnel.
2. Obtain a medical exam before beginning any exercise program.
3. Stop exercising if you feel faint or dizzy. Consult a physician if you are experiencing pain.
4. Inspect equipment prior to use for wear and tear, loose fittings, worn or frayed cables/belts and frame welds. Do not use if it appears damaged or inoperable.
5. Do not attempt to fix or free any jammed parts by yourself. Seek assistance from floor personnel.
6. Use this equipment only for the intended use and for exercise(s) shown in the exercise label.
7. Keep body, clothing and hair clear from all moving parts.
8. Children must not be allowed near this machine. Teenager must be supervised.
9. Make sure the selector pin is completely inserted. Use only the selector pin provided by the manufacturer. If difficulty inserting the pin, seek assistance from floor personnel.
10. Never pin the weights in an elevated position. Do not use the machine if found in this condition. Inform floor personnel immediately.
11. Do not modify selectorized weight stack with any add-on incremental weights or dumbbells, except those with standard factory installed.
12. Do not remove labels affixed to the machine. Replace if damaged.

TuffStuff Fitness International
China, CA 91710, USA



81

DANGER

Use this equipment ONLY for its intended purpose.

If you are unfamiliar with the equipment or procedure, seek assistance from floor personnel.

Failure to comply could result in serious injury or death.

80

DANGER

DO NOT lean against or pull on the framework, weight stack or any component at all times.

Inappropriate or improper use can cause the machine to tip over, and could result in serious injury or death.

85

IMPORTANT

For smooth performance, clean guide rods with Super Lube® spray lubricant and lubricate with Super Lube® (PTFE) grease.

83

IMPORTANT

ADJUST Cable Tension Here

92

WARNING

Keep body, hands and fingers clear of all moving parts.

87

SCHEDULE Replacement Parts

Recommended TuffStuff Parts (replace as needed)	3-MONTH	6-MONTH	12-MONTH	18-MONTH
Upholstery	X			
Foam Rolls	X			
Cables		X		
Rubber Grips		X		
Nylon Handles		X		
Pull-Pins		X		
Plastic Guides		X		
Weight Selector Pin		X		
Abdominal Strap		X		
Adj. Release Handle		X		
Back Caster Wheels		X		
Buckle Seat/Belt		X		

Labels (as needed)

Use only TuffStuff replacement parts when servicing. Failure to do so will void warranty on product and could result in personal injury.

TuffStuff Fitness International
13271 Norton Avenue
China, CA 91710

96

Weight	kg	lb
25	5.5	12.1
29	6.4	14.1
35	7.7	17.0
40	8.8	19.4
50	11.0	24.2
60	13.2	29.1
75	16.5	36.4
90	19.8	43.7
100	22.0	48.5
110	24.2	53.3
120	26.5	58.4
130	28.7	63.3
140	31.0	68.3
150	33.0	72.8

89

WARNING

Anchor bolt here to fasten the machine to the floor.

91

WARNING

Keep body, hands and fingers clear of all moving parts.

89

WARNING

Anchor bolt here to fasten the machine to the floor.

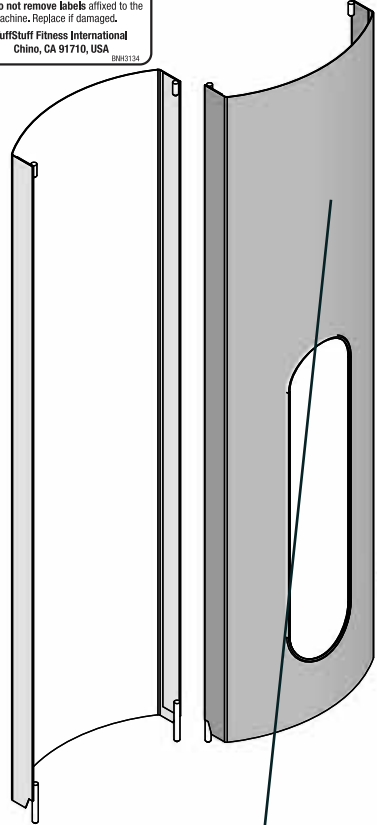

82

Inner/Outer Thigh

Inner/Outer Thigh

1. Sit on the seat with feet flat on the floor.
2. Grasp the handles and pull them towards your chest.
3. Push the handles away from your chest, keeping your feet flat on the floor.
4. Repeat steps 2 and 3 for the desired number of repetitions.

CAUTION:

1. Do not use this exercise if you have any knee, hip, or lower back pain.
2. Do not use this exercise if you have any foot or ankle pain.
3. Do not use this exercise if you have any cardiovascular or respiratory issues.
4. Do not use this exercise if you are pregnant or have any other medical conditions.

DO NOT:

1. Do not use this exercise if you are wearing high-heeled shoes or flip-flops.
2. Do not use this exercise if you are wearing loose clothing or jewelry.
3. Do not use this exercise if you are wearing contact lenses.

TUFFSTUFF FITNESS INTERNATIONAL

Carefully read ALL Danger, Warning & Caution labels posted on the machine

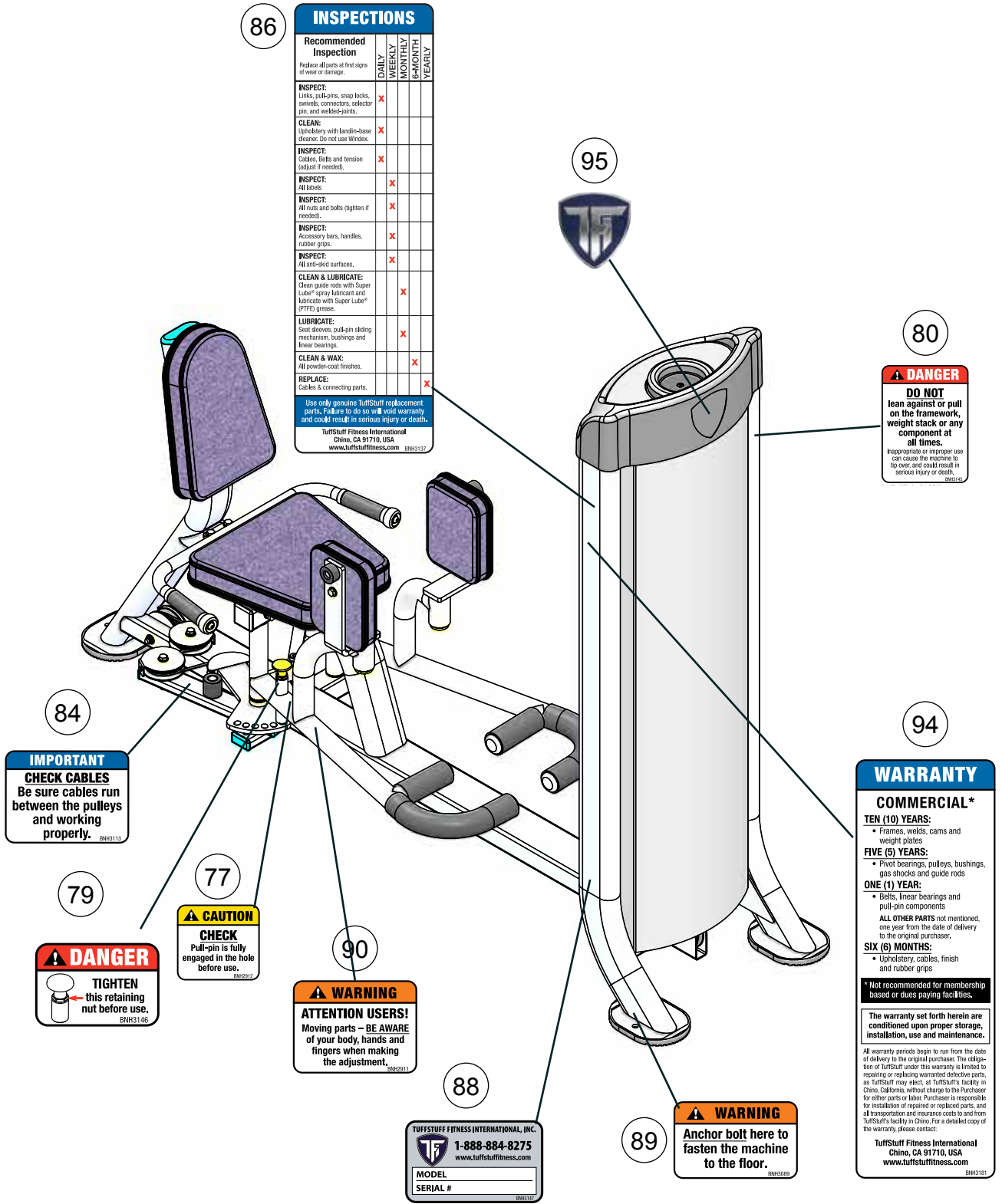

86

INSPECTIONS					
Recommended Inspection	DAILY	WEEKLY	MONTHLY	6-MONTH	YEARLY
INSPECT: Review all parts at three signs of wear or damage.					
INSPECT: Links, pull-pins, snap locks, swivels, connectors, selector pin, and webbed-pins.	X				
CLEAN: Upholstery with lanolin-base cleaner. Do not use Windex.	X				
INSPECT: Cables, belts and tension (adjust if needed).	X				
INSPECT: All belts.	X				
INSPECT: All nuts and bolts (tighten if needed).	X				
INSPECT: Accessory bars, handles, rubber grips.	X				
INSPECT: All anti-skid surfaces.	X				
CLEAN & LUBRICATE: Clean guide rods with Super Lube® spray lubricant and lubricate with Super Lube® (PTFE) grease.		X			
LUBRICATE: Seat sleeves, pull-pin sliding mechanism, bushings and linear bearings.		X			
CLEAN & WAX: All powder-coat finishes.					X
REPLACE: Cables & connecting parts.					X

Use only genuine TuffStuff replacement parts. Failure to do so will void warranty and could result in serious injury or death.
 TuffStuff Fitness International
 China, CA 91710, USA
 www.tuffstufffitness.com BMS1517

84

IMPORTANT
CHECK CABLES
 Be sure cables run between the pulleys and working properly. BMS115

79

DANGER
 TIGHTEN this retaining nut before use. BMS146

77

CAUTION
CHECK
 Pull-pin is fully engaged in the hole before use. BMS212

90

WARNING
ATTENTION USERS!
 Moving parts – BE AWARE of your body, hands and fingers when making the adjustment. BMS281

88

TUFFSTUFF FITNESS INTERNATIONAL, INC.
 1-888-884-8275
 www.tuffstufffitness.com

MODEL _____
 SERIAL # _____

89

WARNING
 Anchor bolt here to fasten the machine to the floor. BMS089

80

DANGER
DO NOT lean against or pull on the framework, weight stack or any component at all times.
 Inappropriate or improper use can cause the machine to tip over, and could result in serious injury or death. BMS080

94

WARRANTY
COMMERCIAL*

TEN (10) YEARS:
 • Frames, welds, cams and weight plates

FIVE (5) YEARS:
 • Pivot bearings, pulleys, bushings, gas shocks and guide rods

ONE (1) YEAR:
 • Belts, linear bearings and pull-pin components

ALL OTHER PARTS not mentioned, one year from the date of delivery to the original purchaser.

SIX (6) MONTHS:
 • Upholstery, cables, finish and rubber grips

*** Not recommended for membership based or dues paying facilities.**

The warranty set forth herein are conditioned upon proper storage, installation, use and maintenance.

All warranty periods begin to run from the date of delivery to the original purchaser. The obligation of TuffStuff under this warranty is limited to repairing or replacing warranted defective parts, as TuffStuff may elect, at TuffStuff's facility in China, California, without charge to the Purchaser for either parts or labor. Purchaser is responsible for installation of repaired or replaced parts and all transportation and insurance costs to and from TuffStuff's facility in China. For a detailed copy of the warranty, please contact:
 TuffStuff Fitness International
 China, CA 91710, USA
 www.tuffstufffitness.com BMS1518

Carefully read ALL Danger, Warning & Caution labels posted on the machine

94

WARRANTY

COMMERCIAL*

TEN (10) YEARS:

- Frames, welds, cams and weight plates

FIVE (5) YEARS:

- Pivot bearings, pulleys, bushings, gas shocks and guide rods

ONE (1) YEAR:

- Belts, linear bearings and pull-pin components

ALL OTHER PARTS not mentioned, one year from the date of delivery to the original purchaser.

SIX (6) MONTHS:

- Upholstery, cables, finish and rubber grips

* Not recommended for membership based or dues paying facilities.

The warranty set forth herein are conditioned upon proper storage, installation, use and maintenance.

All warranty periods begin to run from the date of delivery to the original purchaser. The obligation of TuffStuff under this warranty is limited to repairing or replacing warranted defective parts, as TuffStuff may elect, at TuffStuff's facility in Chino, California, without charge to the Purchaser for either parts or labor. Purchaser is responsible for installation of repaired or replaced parts, and all transportation and insurance costs to and from TuffStuff's facility in Chino. For a detailed copy of the warranty, please contact:

TuffStuff Fitness International
Chino, CA 91710, USA
www.tuffstufffitness.com

BNH3181

87

SCHEDULE

Replacement Parts

Recommended TuffStuff Parts (replace or as needed)	9-MONTH	12-MONTH	15-MONTH	18-MONTH
Upholstery	X			
Foam Rolls	X			
Cables		X		
Rubber Grips		X		
Nylon Handles			X	
Pull-Pins			X	
Plastic Guides			X	
Weight Selector Pin			X	
Abdominal Strap			X	
Adj. Release Handle				X
Black Caster Wheels				X
Buckle Seat/Belt				X
Labels (as needed)				

Use only TuffStuff replacement parts when servicing. Failure to do so will void warranty on product and could result in personal injury.

TuffStuff Fitness International
13971 Norton Avenue
Chino, CA 91710
BNH3135

86

INSPECTIONS

Recommended Inspection	DAILY	WEEKLY	MONTHLY	6-MONTH	YEARLY
Replace all parts at first signs of wear or damage.					
INSPECT: Links, pull-pins, snap locks, swivels, connectors, selector pin, and welded-joints.	X				
CLEAN: Upholstery with lanolin-base cleaner. Do not use Windex.	X				
INSPECT: Cables, Belts and tension (adjust if needed).	X				
INSPECT: All labels		X			
INSPECT: All nuts and bolts (tighten if needed).		X			
INSPECT: Accessory bars, handles, rubber grips.		X			
INSPECT: All anti-skid surfaces.		X			
CLEAN & LUBRICATE: Clean guide rods with Super Lube® spray lubricant and lubricate with Super Lube® (PTFE) grease.			X		
LUBRICATE: Seat sleeves, pull-pin sliding mechanism, bushings and linear bearings.			X		
CLEAN & WAX: All powder-coat finishes.				X	
REPLACE: Cables & connecting parts.					X

Use only genuine TuffStuff replacement parts. Failure to do so will void warranty and could result in serious injury or death.

TuffStuff Fitness International
Chino, CA 91710, USA
www.tuffstufffitness.com BNH3137

93

⚠ WARNING

Serious injury or death can occur if these rules and precautions are not observed:

1. **Read and Understand** Owner's Manual and all DANGER, WARNING and CAUTION labels before using this equipment. If you still need help, seek assistance from floor personnel.
2. Obtain a **medical exam** before beginning any exercise program.
3. **Stop exercising** if you feel faint or dizzy. Consult a physician if you are experiencing pain.
4. **Inspect equipment** prior to use for wear and tear, loose fittings, worn or frayed cables/belts and frame welds. Do not use if it appears damaged or inoperable.
5. **Do not attempt to fix** or free any jammed parts by yourself. Seek assistance from floor personnel.
6. **Use this equipment only for the intended use** and for exercise(s) shown in the exercise label.
7. Keep body, clothing and hair **clear from all moving parts**.
8. **Children must not be allowed** near this machine. Teenager must be supervised.
9. **Make sure the selector pin** is completely inserted. Use only the selector pin provided by the manufacturer. If difficulty inserting the pin, seek assistance from floor personnel.
10. **Never pin the weights in an elevated position**. Do not use the machine if found in this condition. Inform floor personnel immediately.
11. **Do not modify selectorized weight stack** with any add-on incremental weights or dumbbells, except those with standard factory installed.
12. **Do not remove labels** affixed to the machine. Replace if damaged.

TuffStuff Fitness International
Chino, CA 91710, USA
BNH3134

83

IMPORTANT

ADJUST

Cable Tension Here

BNH2924

81

⚠ DANGER

Use this equipment **ONLY** for its intended purpose.

If you are unfamiliar with the equipment or procedure, seek assistance from floor personnel.

Failure to comply could result in serious injury or death.
BNH3088

80

⚠ DANGER

DO NOT lean against or pull on the framework, weight stack or any component at all times.

Inappropriate or improper use can cause the machine to tip over, and could result in serious injury or death.
BNH3145

84

IMPORTANT

CHECK CABLES

Be sure cables run between the pulleys and working properly.

BNH3113

85

IMPORTANT

For smooth performance, clean guide rods with Super Lube® spray lubricant and lubricate with Super Lube® (PTFE) grease.
BNH2925

92

⚠ WARNING

Keep body, hands and fingers clear of all moving parts.

BNH2926

79

⚠ DANGER

TIGHTEN this retaining nut before use.

BNH3146

89

⚠ WARNING

Anchor bolt here to fasten the machine to the floor.

BNH3089

91

⚠ WARNING

Keep body, hands and fingers clear of all moving parts.

BNH2909

90

⚠ WARNING

ATTENTION USERS!

Moving parts – BE AWARE of your body, hands and fingers when making the adjustment.

BNH2911

Carefully read ALL Danger, Warning & Caution labels posted on the machine

88



95



82



96

TOP PLATE 10 lbs.	TOP PLATE 4.5 kgs.
20 lbs.	9.1 kgs.
30 lbs.	13.6 kgs.
40 lbs.	18.1 kgs.
50 lbs.	22.7 kgs.
60 lbs.	27.2 kgs.
70 lbs.	31.8 kgs.
80 lbs.	36.3 kgs.
90 lbs.	40.8 kgs.
100 lbs.	45.4 kgs.
110 lbs.	49.9 kgs.
120 lbs.	54.4 kgs.
130 lbs.	59.0 kgs.
140 lbs.	63.5 kgs.
150 lbs.	68.0 kgs.

78



77



76

BE ALERT!

THE FITNESS EQUIPMENT IN THIS FACILITY PRESENTS HAZARDS WHICH, IF NOT AVOIDED, COULD CAUSE SERIOUS INJURY OR DEATH.

Prior to using the equipment, READ the warning labels and instruction placards affixed to each machine.

If you are unsure on how to use a machine, seek the assistance of our floor personnel. We will be happy to instruct you on how to use the equipment properly.

Immediately report any piece of equipment that is not functioning properly to our floor personnel so that it may be evaluated and service promptly.

DO NOT ATTEMPT to use or fix any piece of equipment that is not functioning properly.

ASTM F1749-06 TUFFSTUFF FITNESS INTERNATIONAL, CHINO, CA 91710
BNH3138

It is extremely important that the **Facility Sign** shown to the left be installed in plain view of the unit.

You should have received it along with this Owner's Manual. If you did not receive this Facility Sign with your order, you can obtain one at no cost to you from TuffStuff Fitness by contacting our service department at:

1 (888) 884-8275
service@tuffstuff.net
service1@tuffstuff.net

Anchoring Unit

Holes on frame are provided for anchoring the unit to the floor. See anchoring hole location below.

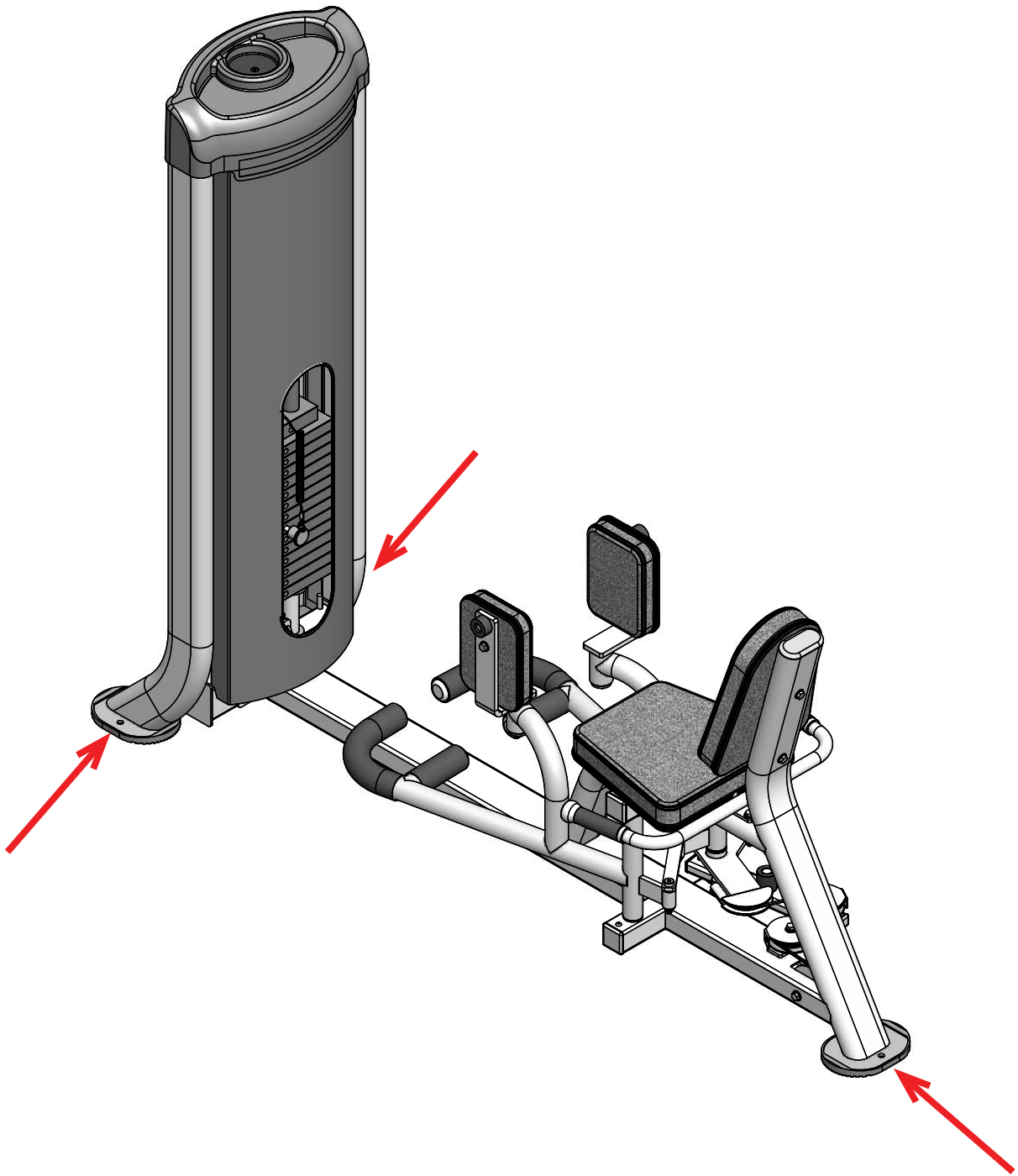

⚠ WARNING
Anchor bolt here to
fasten the machine
to the floor.
BNH3089

Important Safety Instructions



It is the responsibility of the facility owner and/or owner of the equipment to review the Owner's Manual with their facility personnel and understand all Danger, Warning and Caution labels affixed on the machine. It is the responsibility of the floor personnel to instruct users on proper operation of the equipment and review all danger, warning and caution labels.

⚠ WARNING SERIOUS INJURY OR DEATH CAN OCCUR IF THESE SAFETY PRECAUTIONS ARE NOT OBSERVED:

1. Obtain a medical exam before beginning any exercise program.
2. Read and understand Owner's Manual and all **Danger, Warning and Caution** labels before using this equipment. If you still need help, seek assistance from floor personnel.
3. **Inspect the equipment** before each use for wear and tear, loose fittings, worn or frayed cables and frame welds. **DO NOT USE** if it appears to be inoperable or damaged.
4. Stop exercising if you feel faint or dizzy. Consult a physician if you are experiencing pain.
5. **Use this equipment only for the intended use.**
6. Keep body, clothing and hair clear from all moving parts. Do not attempt to free any jammed parts by yourself.
7. Always warm-up before and cool-down after weight training. Warm-up for 10-15 minutes with stretching and cardiovascular exercises. Cool-down should include light stretching exercises for 5-15 minutes.
8. Never hold your breath – will limit the flow of oxygen to your brain and may cause dizziness. The most often used breathing pattern is inhaling during least resistance and exhaling during maximum resistance.
9. Do not use accessories or accessory attachments that are not recommended by TFI.
10. Make sure selector pin is completely inserted. Use only the selector pin provided by the manufacturer.
11. Never pin the weights in an elevated position. Do not use the machine if found in this condition.
5. Provide an adequate safety perimeter between the machine, walls and other equipment to ensure that the facility has proper clearance for usage and training.
6. Post and disclose all safety, rules and regulations on a bulletin board easily accessible to users.
7. Perform regular maintenance (see Inspection Label). Pay special attention to areas most susceptible to wear and tear, including but not limited to cables, pulleys and rubber grips.
8. **Do not** lean against or pull on the framework, weight stack or any component at all times.
9. **Children must not** be allowed near the equipment. Teenager must be supervised.
10. Replace immediately all parts at first sign of wear or damage. If unable to replace worn or damaged components/parts, remove machine from service until the repair is made.
11. Use only genuine TuffStuff replacement parts. Failure to do so will void warranty and could result in serious injury or death to the users.
12. **Do not remove** any decals affixed to the machine. Replace if damaged.
13. **Do not alter or modify** the original manufacturer's weight stack with any add-on incremental weights, weight plates or dumbbells except those with standard factory installed option.
14. Maintain a service contract with a TFI Authorized Dealer or a Professional Service Company approved by TFI. Keep a service log of all maintenance and repair activities. **NOTICE:** It is the sole responsibility of the owner or facility operator to ensure that regular maintenance is performed.

Facility Safety Guidelines and Practices

1. Read and understand the Owner's Manual before assembling, servicing or using the equipment.
2. Equipment to be installed by TFI Authorized Dealer or Professional Service Company approved by TFI.
3. Make sure each machine is set up and operated on a solid level surface. Do not install equipment on an uneven surface.
4. **Anchoring of equipment must be completed** at time of installation and inspected prior to use. Failure to anchor the machine to the floor could cause the machine to tip or fall over due to incorrect usage and misuse, and could result in serious injury or death.



DANGER: indicates an imminently hazardous situation which, if not avoided, will result in death or serious injury.



WARNING: indicates a potentially hazardous situation which, if not avoided, will result in death or serious injury.



CAUTION: indicates a hazardous situation which, if not avoided, could result in minor or moderate injury.

Registration, Service & Assembly



Thank you for purchasing the CG-9515 Inner/Outer Thigh. This machine is part of the TuffStuff line of quality strength training equipment. To maximize your use of the equipment, please study the Owner's Manual thoroughly.

Registration

To avoid unnecessary delays on warranty parts and to insure that a permanent record of your purchase is on file with our company, be sure to register online at <http://www.tuffstufffitness.com> or mail to address shown below within 10 days of purchase.

Obtaining Service

Please use this Owner's Manual as your guide to all parts included in your shipment. When ordering parts, you must specify the part number and description from this owner's manual. **Use only genuine TuffStuff replacement parts when servicing the equipment.** Failure to do so will void warranty and could result in serious injury or death.

For information about product operation or service:

Phone: 909-629-1600 Toll Free 888-884-8275
Fax: 909-629-4967
E-mail: service@tuffstuff.net or service1@tuffstuff.net
Hours: M-F 8:00 – 4:30 PST
Or write to: TuffStuff Fitness International Inc.
Customer Service
13971 Norton Avenue, Chino, CA 91710

Retain this Owner's Manual for future reference when ordering service or parts. To assist you better, please be prepared to provide the following information:

1. Model Number
2. Place of Purchase
3. Serial Number
4. Part # and Description

Required Tools

The basic tools that you will need to assemble the CG-9515 but are not limited to:

- 9/16", 3/4", 1/2" combination wrenches
- Adjustable wrench
- Ratchet wrench with 9/16", 3/4", 1/2" sockets
- External retaining ring pliers
- Rubber mallet, measuring tape & utility knife
- Super Lube® spray lubricant and grease
- Windex or household glass cleaner

Assembly Requirements

Follow these installation requirements when assembling the CG-9515. Use the overhead view on the Content Page to layout your floor plan before assembling.

Set up the CG-9515 on a clean, solid, flat surface. A smooth, flat surface under the machine helps keep it level.

Allow ample space around the machine for safe unrestricted use and easier access.

Insert all bolts in the same direction. For aesthetic appearance, insert all bolts in the same direction unless specified (in text or illustration) to do otherwise.

Leave room for adjustments. Do not fully tighten fasteners until instructed in the assembly steps to do so (to prevent any difficulty with alignment of parts during the assembly process). When not instructed, tighten fasteners such as bolts, nuts and screws so the unit is stable, but leave room for adjustments.

Assembly Tips

Read all "Notes" on each page before beginning each step.

While you may be able to assemble the CG-9515 using the illustrations only, IMPORTANT safety notes and other tips are included in the text.

Some pieces may have extra holes that you will not use. Use only those holes indicated in the instructions and illustration.

NOTE: With so many assembled parts, proper alignment and adjustment is critical. While tightening the nuts and bolts, be sure to leave room for final adjustments.

CAUTION: Obtain assistance from TFI if you have difficulty assembling the CG-9515. Please do not attempt to complete the assembly as this could result in equipment failure and serious injuries to the users.

Symbols & Description

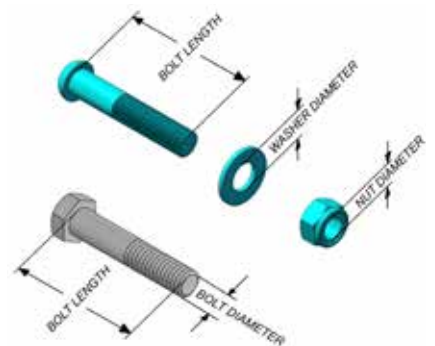

Loosely Tighten

70%

Fully Tighten

100%

Loosely Tighten

Loosely tighten all hardware in this step. DO NOT Fully Tighten. Some component(s) may need pre-assembly and or alignment during the assembly process.

Fully Tighten

Wrench tighten all hardware in this step.



WARNING:

THE FOLLOWING CONDITIONS MAY INDICATE A WORN CABLE. REPLACE IMMEDIATELY.



"NECKING", STRETCHED CABLE COVERING



A CRACK IN THE CABLE COVER



A TEAR IN THE CABLE COVER



A BREAK ON THE CABLE



CABLE END SLIPPING OUT

IMPORTANT NOTE:

DAMAGED OR WORN CABLE (AS SHOWN ABOVE) MAY DAMAGE THE PULLEY(S). YOU MUST INSPECT THE PULLEYS AT THIS TIME FOR WEAR AND TEAR. REPLACE IF NEEDED.

Step 1



Step 1 Assembly List

Item #	Description	Qty.
11	MAIN FRAME	1
22	WEIGHT STACK FRAME	1
40	FLAT WASHER 3/8 ID X 1 1/2 OD X 3/16 THICK	3
42	FLAT WASHER SAE Z/P 3/8"	3
50	HEX HEAD CAP SCREW GR-5 Z/P 3/8-16 X 3	3
55	NYLON INSERT THIN PATTERN LOCK NUT Z/P 3/8-16	3

NOTE:

1. It is strongly recommended that 2 people participate in the assembly of this unit.
2. Be sure to hold the weight stack frame perpendicular to floor before tightening the screws.

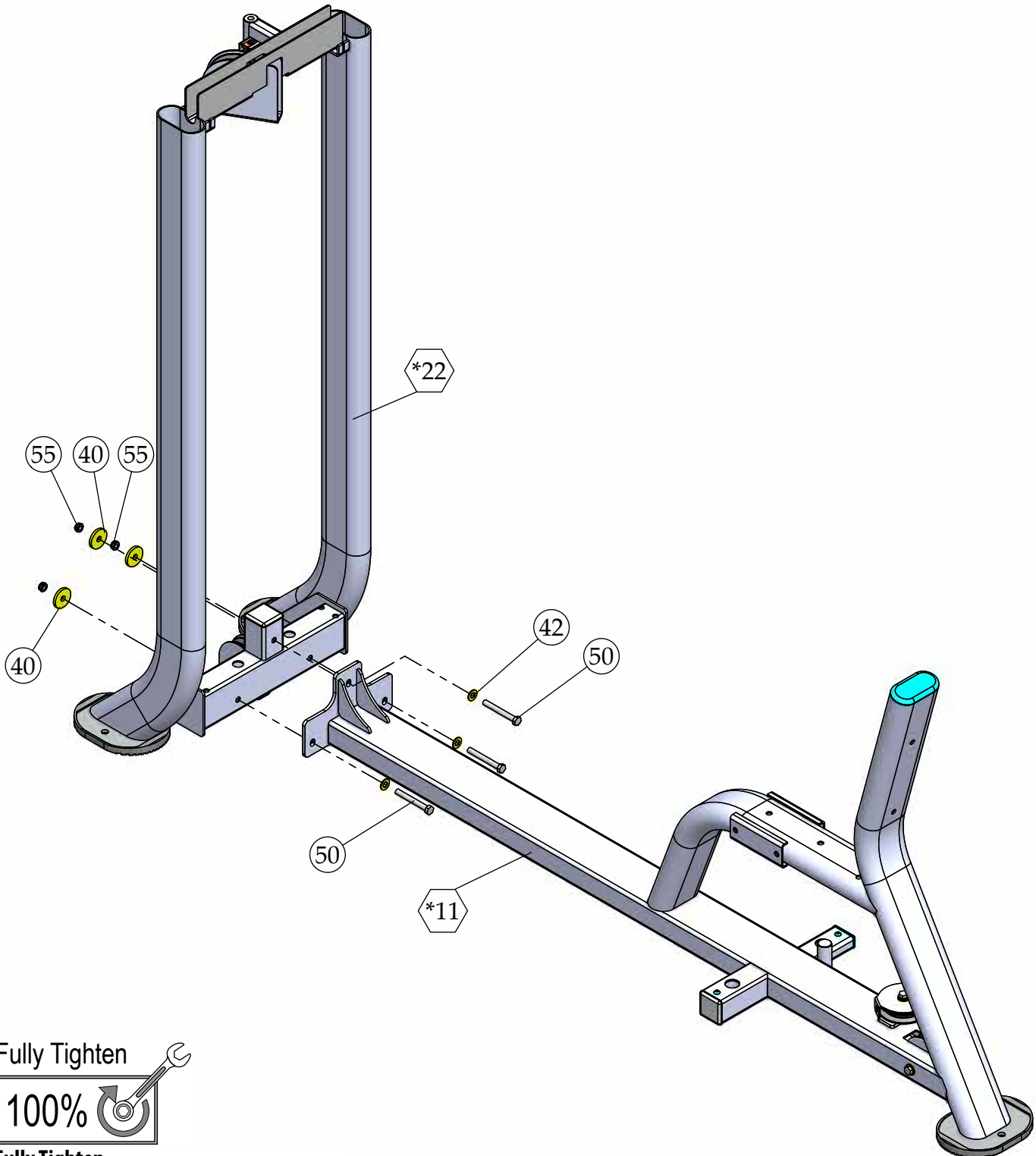

Fully Tighten

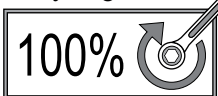

Fully Tighten

Wrench tighten all hardware in this step.

Step 2



Step 2 Assembly List		
Item #	Description	Qty.
2	CAM	1
3	CAM SUPPORT TUBE	1
8	LEFT LEG ARM	1
12	PIVOT ACTUATOR PLATE	1
13	PIVOT AXLE 1"X 13 1/4"	2
14	PIVOT AXLE SUPPORT TUBE	2
15	RIGHT LEG ARM	1
42	FLAT WASHER SAE Z/P 3/8"	6
52	HEX HEAD CAP SCREW GR-5 Z/P 3/8-16 X 5 1/4	2
55	NYLON INSERT THIN PATTERN LOCK NUT Z/P 3/8-16	4

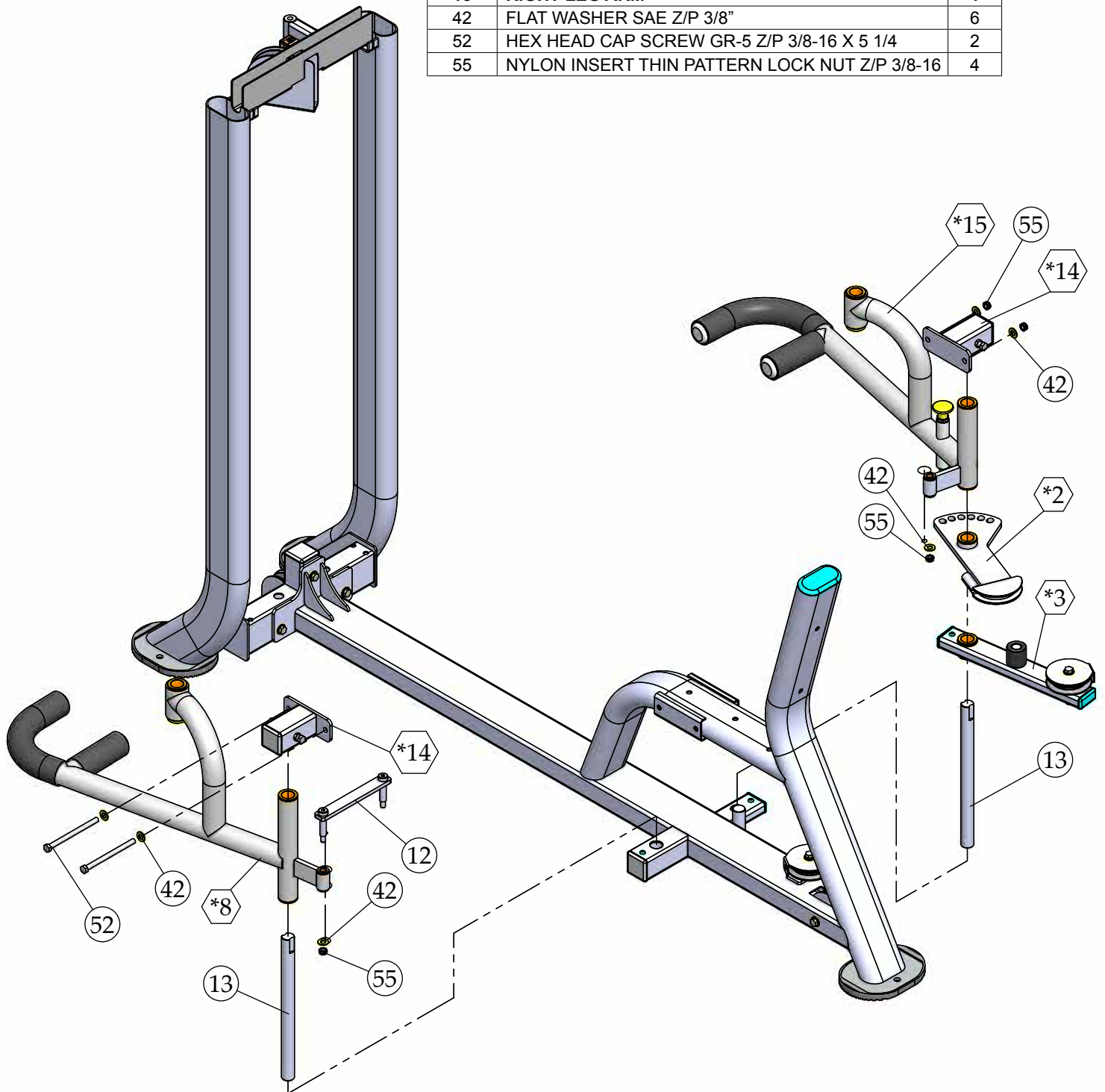

Step 3



Step 3 Assembly List

Item #	Description	Qty.
6	HANDLES	1
42	FLAT WASHER SAE Z/P 3/8"	4
49	HEX HEAD CAP SCREW GR-5 Z/P 3/8-16 X 2 3/4	2
55	NYLON INSERT THIN PATTERN LOCK NUT Z/P 3/8-16	2

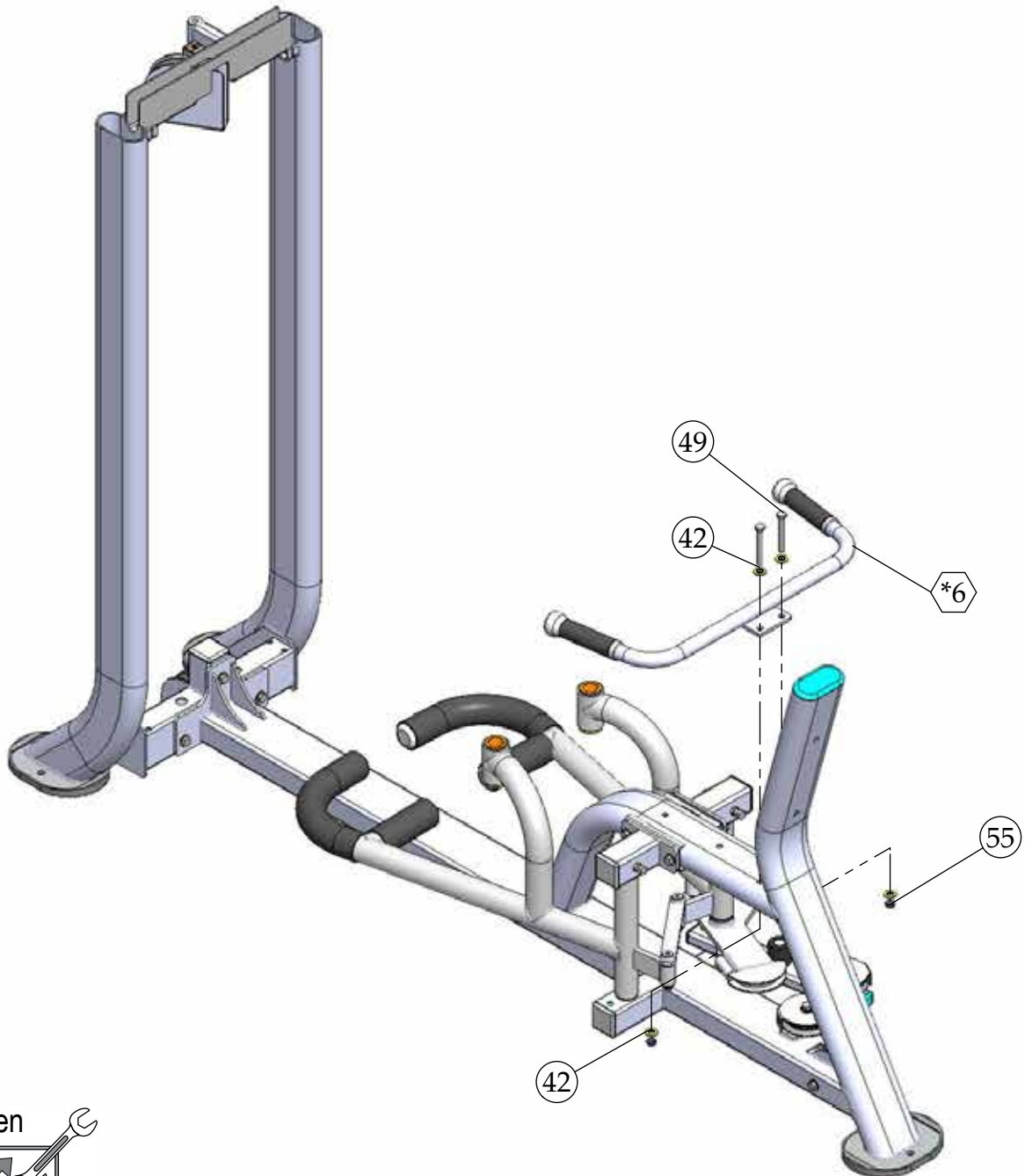

Fully Tighten

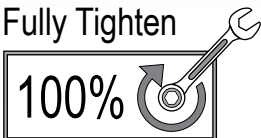

Fully Tighten

Wrench tighten all hardware in this step.

Step 4

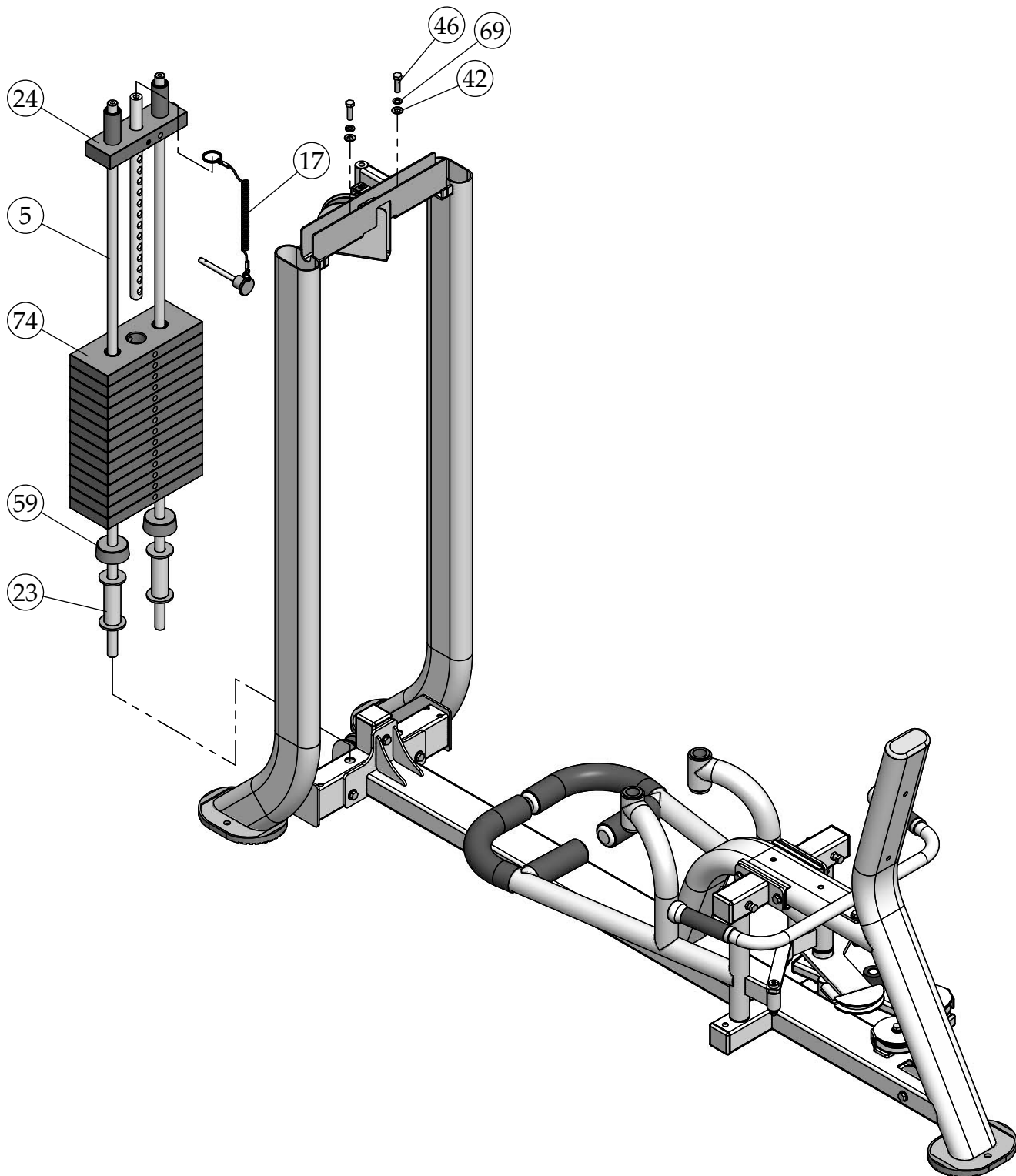

Fully Tighten 

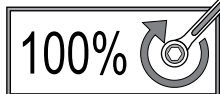

Fully Tighten
Wrench tighten all hardware in this step.



Step 4 Assembly List

Item #	Description	Qty.
5	GUIDE ROD 3/4 RD X 50 3/8	2
17	SELECTOR PIN W/COIL 3/8 X 4 GOLD KNOB	1
23	WEIGHT STACK SPACER 4"	2
24	10 LB TOP PLATE W/ADJ SLTR BAR 19 BLK	1
42	FLAT WASHER SAE Z/P 3/8"	2
46	HEX HEAD CAP SCREW GR-5 Z/P 3/8-16 X 1 1/4	2
59	RUBBER DONUT 3/4 X 2 1/2	2
69	SPLIT LOCK WASHER Z/P 3/8"	2
74	10 LB STEEL WEIGHT PLATE BLACK 4 X 10 (EA)	14
96	LABEL-NUMBERS 10-150 LBS/KGS 7/8 X 3 YELLOW	1

NOTE:

1. TOP PLATE LABEL GOES ON HOLE OFF CENTER AS SHOWN. LABEL WILL COVER HOLE ON CENTER.

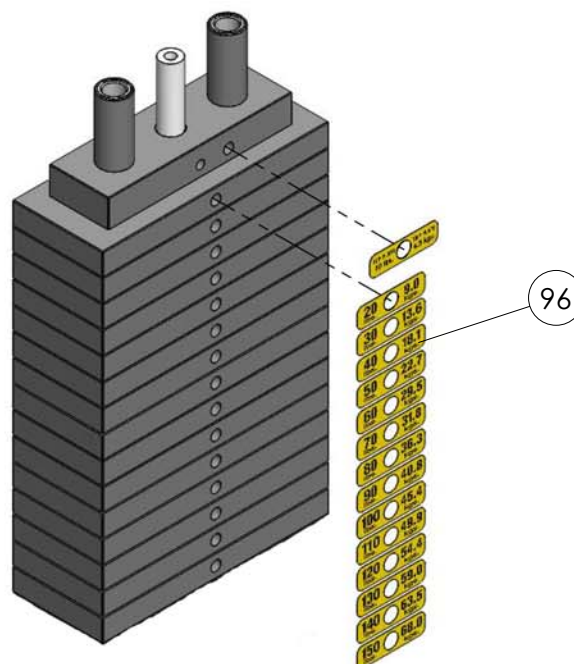

Weight stack label and lubrication instructions

1. Wipe front surface of weight stack with rubbing alcohol and wipe dry.
2. Peel off back sheet (adhesive side) from label (#96) and make sure that the label remains attached to the application tape.
3. Line up left edge of label sheet with outside edge of weight holes.
4. Line up the first label to hole on top plate.
5. Make sure label is straight and slowly press into place.
6. Gently remove application tape and rub each label firmly against the weight stack.
7. Allow labels to stand for 2 days to allow adhesive to cure fully.
8. Open the lube package provided and apply a thin film of lubricant around the first 3 inches of the guide rods above the top plate.
9. After the cables are installed, do a set of reps to spread the lubricant thoroughly.

Step 5 Cable Routing

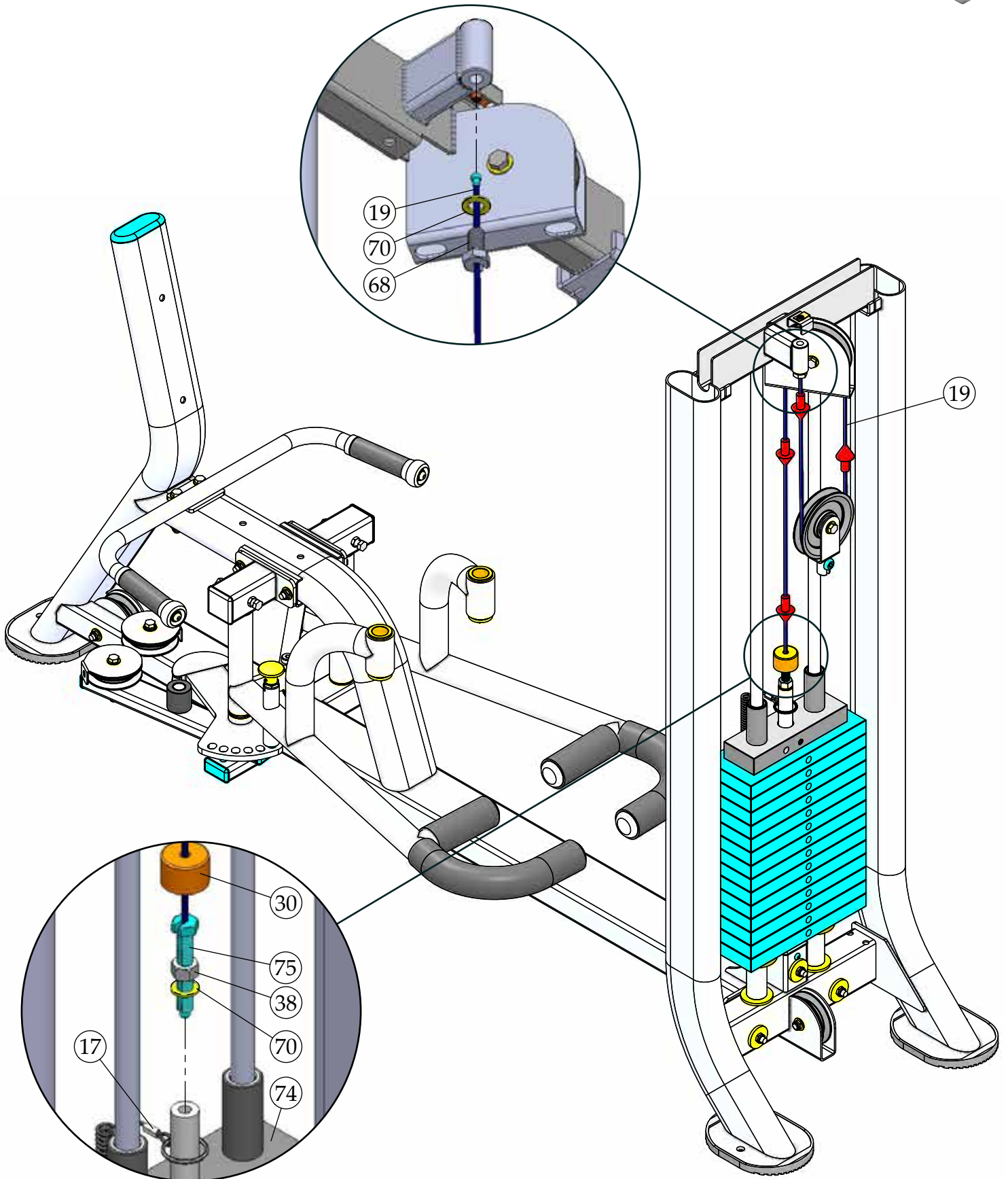

Step 5 Assembly List

Item #	Description	Qty.
17	SELECTOR PIN W/COIL 3/8 X 4 GOLD KNOB	1
19	TENSION CABLE	1
30	BLACK NYLON BUMPER	1
38	FINISHED HEX NUT Z/P 1/2-13	1
68	SPLIT BOLT GR-5 Z/P 1/2-13 X 1 1/4 (RND CUT)	1
70	SPLIT LOCK WASHER Z/P 1/2"	2
75	SPLIT BOLT GR-8 Z/P 1/2-13 X 3 1/2 (RND CUT)	1

Fully Tighten

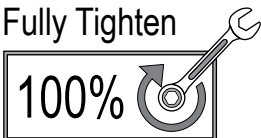

Fully Tighten

Wrench tighten all hardware in this step.

Step 6 Cable Routing

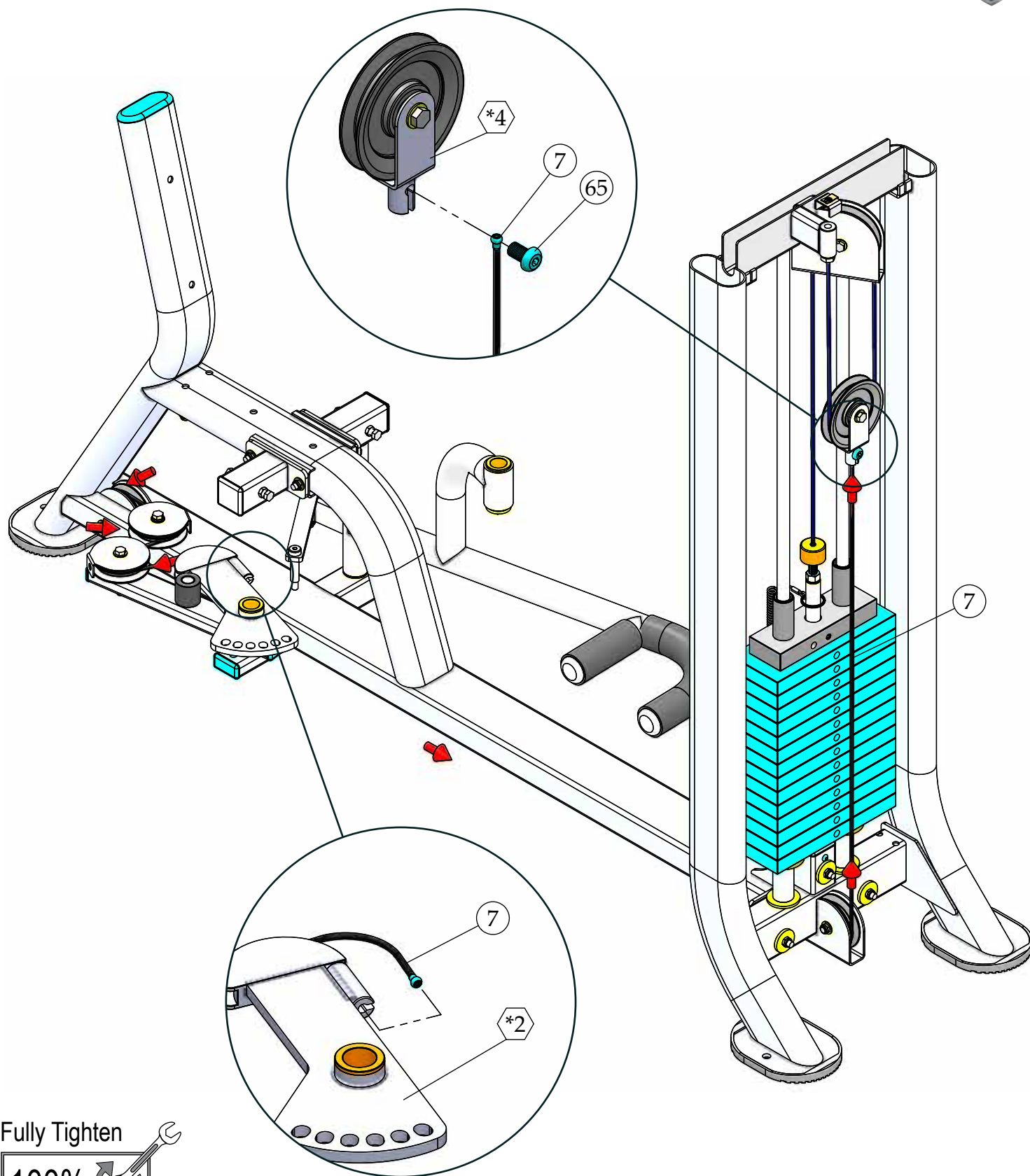

Fully Tighten

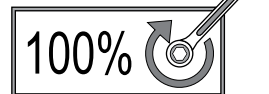

Fully Tighten

Wrench tighten all hardware in this step.



Step 6 Assembly List

Item #	Description	Qty.
4	FLOATING PULLEY BRACKET	1
7	INNER OUTER CABLE	1
65	BUTTON HEAD SOCKET CAP SCREW Z/P 7/16-14 X 5/8	1

Step 7



Step 7 Assembly List

Item #	Description	Qty.
20	WEIGHT SHIELD FRONT	1
21	WEIGHT SHIELD REAR	1
39	FLAT HEAD SOCKET CAP SCREW Z/P M6-1.0 X 50	1
57	PLASTIC SHROUD LID	1

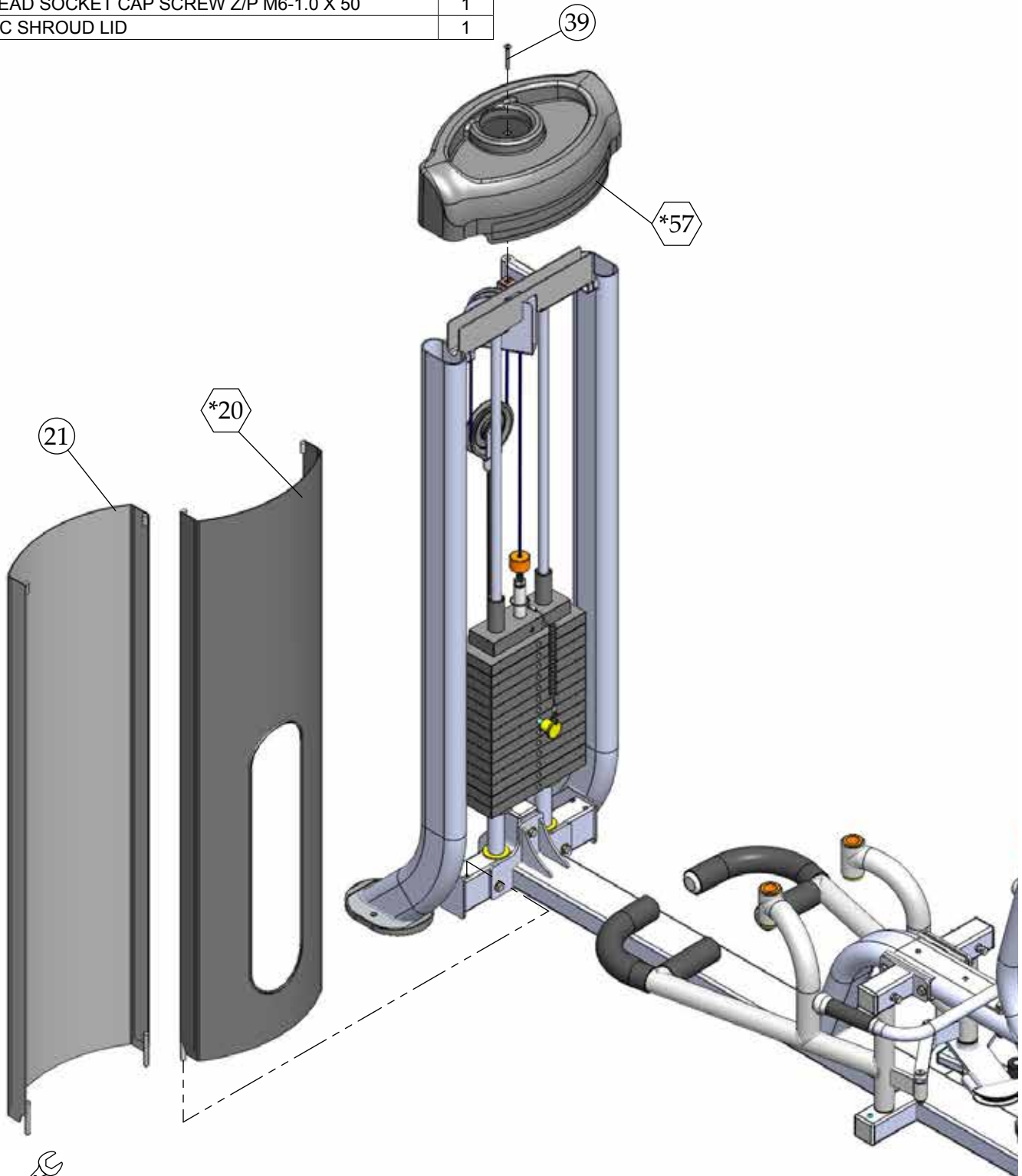

Fully Tighten 

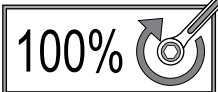

Fully Tighten

Wrench tighten all hardware in this step.

Step 8



Step 8 Assembly List

Item #	Description	Qty.
1	BACK PAD	1
9	LEG PAD	2
10	LEG PAD PIVOT BRACKET	2
16	SEAT PAD	1
40	FLAT WASHER 3/8 ID X 1 1/2 OD X 3/16 THICK	2
42	FLAT WASHER SAE Z/P 3/8"	6
44	HEX HEAD CAP SCREW GR-5 Z/P 3/8-16 X 1	2
45	BUTTON HEAD SOCKET CAP SCREW Z/P 3/8-16 X 1 1/2	2
46	HEX HEAD CAP SCREW GR-5 Z/P 3/8-16 X 1 1/4	2
50	HEX HEAD CAP SCREW GR-5 Z/P 3/8-16 X 3	4
58	RUBBER BUMPER W/WASHER 3/8 X 1 1/2	2
69	SPLIT LOCK WASHER Z/P 3/8"	4

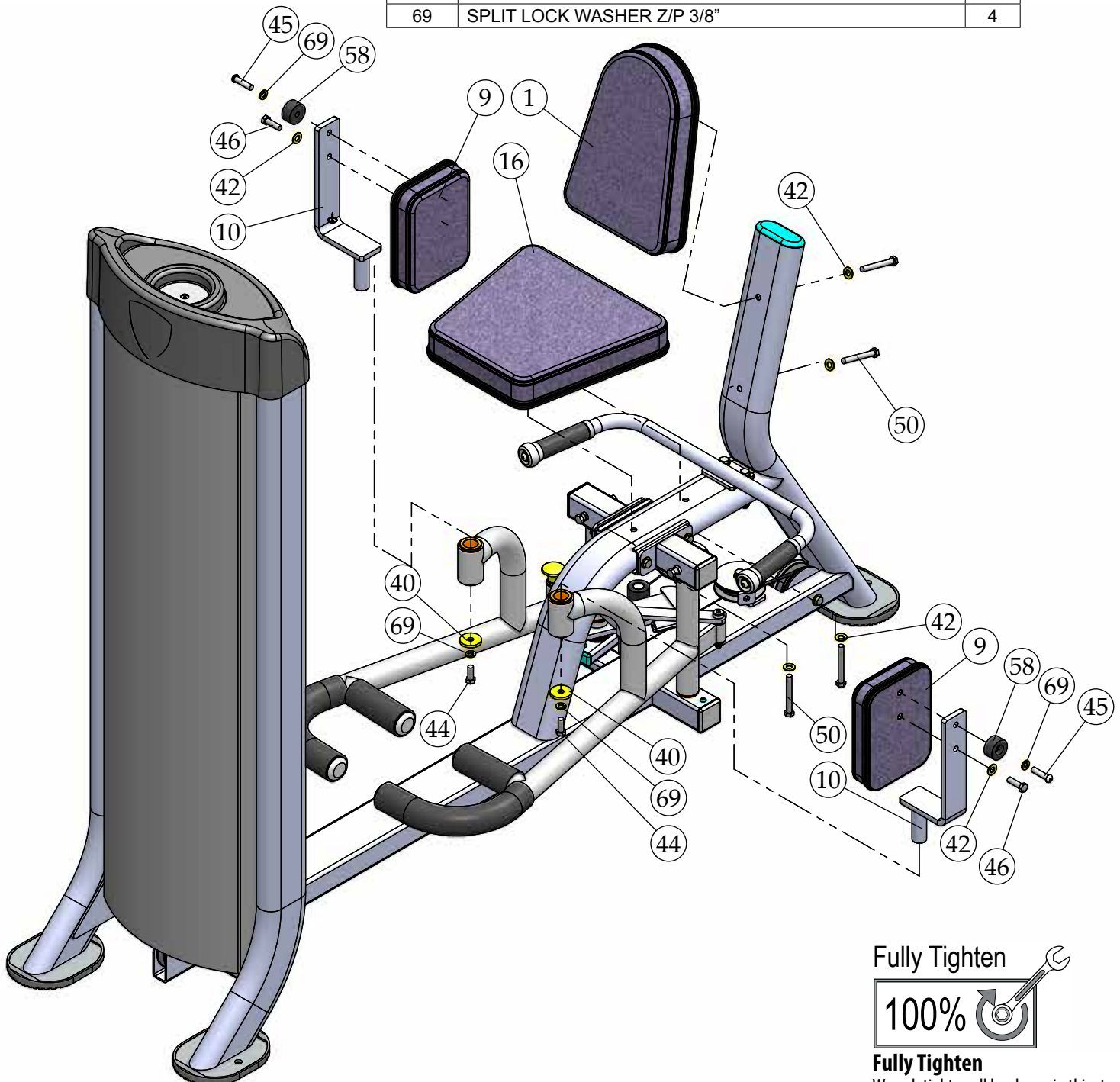

Fully Tighten

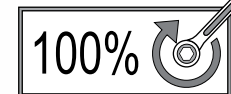

Fully Tighten

Wrench tighten all hardware in this step.

Parts List



COLOR CHART
GRAY= SUB-ASSEMBLY PARTS
BLACK= HARDWARE

CG-9515 Parts List

Item No.	Description	Rev.	Part No.	Qty.	Item No.	Description	Rev.	Part No.	Qty.
1	BACK PAD	0	UP8819	1	49	HEX HEAD CAP SCREW GR-5 Z/P 3/8-16 X 2 3/4		BNH2045	2
2	CAM	0	UP8820	1	50	HEX HEAD CAP SCREW GR-5 Z/P 3/8-16 X 3		BNH2046	8
3	CAM SUPPORT TUBE	0	UP8821	1	51	HEX HEAD CAP SCREW GR-5 Z/P 3/8-16 X 4 1/2		BNH2052	1
4	FLOATING PULLEY BRACKET	0	UP8822	1	52	HEX HEAD CAP SCREW GR-5 Z/P 3/8-16 X 5 1/4		BNH4270	2
5	GUIDE ROD 3/4 RD X 50 3/8	0	UP8461	2	53	HEX KEY ALLOY 7/32"		BNH0575	1
6	HANDLES	0	UP8823	1	54	FINISHED HEX JAM NUT Z/P 3/8-16		BNH0200	4
7	INNER OUTER CABLE	0	UP8824	1	55	NYLON INSERT THIN PATTERN LOCK NUT Z/P 3/8-16		BNH2026	14
8	LEFT LEG ARM	0	UP8825	1	56	NYLON PULLEY 3/8 X 1 X 4 1/2 BLACK		BNH0506	2
9	LEG PAD	0	UP8826	2	57	PLASTIC SHROUD LID		BNH3393	1
10	LEG PAD PIVOT BRACKET	0	UP8827	2	58	RUBBER BUMPER W/WASHER 3/8 X 1 1/2		BNH0514	2
11	MAIN FRAME	0	UP8828	1	59	RUBBER DONUT 3/4 X 2 1/2		BNH0068	2
12	PIVOT ACTUATOR PLATE	0	UP8829	1	60	RUBBER GRIP 1 ID X .125 X 4		BNH0931	2
13	PIVOT AXLE 1"X 13 1/4"	0	UP7519	2	61	RUBBER TUBE 1.625 ID X .125 WALL X 5		BNH3696	2
14	PIVOT AXLE SUPPORT TUBE	0	UP8830	2	62	RUBBER TUBE 1.625 ID X .125 WALL X 12		BNH3697	2
15	RIGHT LEG ARM	0	UP8831	1	63	SHROUD LID RUBBER MAT LARGE		BNH3394	1
16	SEAT PAD	0	UP8832	1	64	SHROUD LID RUBBER MAT SMALL		BNH3395	1
17	SELECTOR PIN W/COIL 3/8 X 4 GOLD KNOB	0	UP3035	1	65	BUTTON HEAD SOCKET CAP SCREW Z/P 7/16-14 X 5/8		BNH3709	1
18	SMALL COVER PLATE 3 1/2" PULLEY	0	UP8833	2	66	PULL PIN 1/2 X 5 5/8 STIFF SPRING (YELLOW KNOB)		BNH4075	1
19	TENSION CABLE	0	UP8834	1	67	SOCKET SET SCREW Z/P 10-32 X 1/8		BNH2088	1
20	WEIGHT SHIELD FRONT	0	UP8468	1	68	SPLIT BOLT GR-5 Z/P 1/2-13 X 1 1/2 (RND CUT)		BNH2184	1
21	WEIGHT SHIELD REAR	0	UP8459	1	69	SPLIT LOCK WASHER Z/P 3/8"		BNH2520	9
22	WEIGHT STACK FRAME	0	UP8835	1	70	SPLIT LOCK WASHER Z/P 1/2"		BNH0572	2
23	WEIGHT STACK SPACER 3"	0	UP8836	2	71	SUPER LUBE TEFLON LUBRICANT 82340		BNH0704	2
24	10 LB TOP PLATE W/ADJ SLTR BAR 19 BLK WTS ASM		BNH1982	1	72	HEX KEY ALLOY 3/32"		BNH0372	1
25	ALUMINUM CAP 1.040" RD (026-01M0937)		BNH3082	2	73	U-STYLE TAPPED HOLE NUT M6		BNH3351	1
26	ALUMINUM INSERT CAP 1 3/4 RD WITH O-RINGS		BNH4184	4	74	10 LB STEEL WEIGHT PLATE BLACK 4 X 10 (EA)		BNH4345	14
27	ALUMINUM INSERT CAP 1 X 2		BNH1500	3	75	SPLIT HEX TAP BOLT GR-8 Z/P 1/2 -13 X 3 1/2 (RND CUT)		BNH2977	1
28	ALUMINUM INSERT CAP 2 SQ		BNH1502	4	76	FACILITY SIGN BE ALERT! THE FITNESS EQUIPMENT		BNH3138	1
29	ALUMINUM INSERT CAP ELLIPTICAL 100MM X 50MM		BNH2398	1	77	LABEL-CAUTION CHECK PULL-PIN IS FULLY... 1 1/2 X 1 3/8		BNH2912	1
30	BLACK NYLON BUMPER		BNH3308	1	78	LABEL-CG-9500 SERIES PANTONE ON CHROME BASE		BNH3172	1
31	BLACK NYLON PULLEY 3/8 X 1 X 3 1/2 (P-35375-H)		BNH0553	4	79	LABEL-DANGER CHECK RETAINING NUT... 1.5 X 1		BNH3146	1
32	BRONZE BUSHING 1 X 1 1/4 X 3/4 X 1 1/2 X 1/8		BNH0527	12	80	LABEL-DANGER DO NOT LEAN AGAINST, 1.75X2.375		BNH3145	2
33	BRONZE BUSHING SAE 841 (302033) .502X.628 X 1/2 X 7/8 X 1/8"		BNH0528	4	81	LABEL-DANGER USE THIS EQUIP. ONLY (COMM. LINE) 1.5 X 2.375		BNH3088	1
34	BUTTON HEAD SOCKET CAP SCREW GR-8 Z/P 1/4-20 X 3/8		BNH3698	7	82	LABEL-EXERCISE CHART (CG-9515)		BNH3195	1
35	BUTTON HEAD SOCKET CAP SCREW Z/P 3/8-16 X 1		BNH2033	2	83	LABEL-IMPORTANT ADJUST CABLE TENSION HERE		BNH2924	1
36	EDGE PROTECTOR CHROME 11 GA		BNH1724	1	84	LABEL-IMPORTANT CHECK CABLES		BNH3113	1
37	ELLIPTICAL RUBBER SHOE		BNH3323	3	85	LABEL-IMPORTANT FOR SMOOTH PERFORMANCE...		BNH2925	1
38	FINISHED HEX NUT Z/P 1/2-13		BNH0206	1	86	LABEL-INSPECTIONS RECOMMENDED INSPECTION...		BNH3137	1
39	FLAT HEAD SOCKET CAP SCREW Z/P M6-1.0 X 50		BNH3705	1	87	LABEL-SCHEDULE REPLACEMENT PARTS...		BNH3135	1
40	FLAT WASHER 3/8 ID X 1 1/2 OD X 3/16 THICK		BNH1717	5	88	LABEL-TFI SERIAL NO. 2.5 X 1.5		BNH3147	2
41	HEX KEY ALLOY 4 MM		BNH3708	1	89	LABEL-WARNING ANCHOR BOLT, 2 X 1 1/4"		BNH3089	3
42	FLAT WASHER SAE Z/P 3/8"		BNH2030	32	90	LABEL-WARNING ATTENTION USERS!... 2X1.5		BNH2911	1
43	HARD PVC STOPPER 20MM ID X 38MM OD X 38MM		BNH3695	1	91	LABEL-WARNING KEEP BODY, HANDS... 1 1/2 X 2 5/8		BNH2909	1
44	HEX HEAD CAP SCREW GR-5 Z/P 3/8-16 X 1		BNH2037	2	92	LABEL-WARNING KEEP BODY, HANDS... 1X2-5/8		BNH2926	1
45	BUTTON HEAD SOCKET CAP SCREW Z/P 3/8-16 X 1 1/2		BNH2035	2	93	LABEL-WARNING_SERIOUS INJURY OR DEATH		BNH3134	1
46	HEX HEAD CAP SCREW GR-5 Z/P 3/8-16 X 1 1/4		BNH2038	8	94	LABEL-COMMERCIAL WARRANTY		BNH3181	1
47	HEX HEAD CAP SCREW GR-5 Z/P 3/8-16 X 1 3/4		BNH2040	3	95	LABEL-TFI 4 HIGH X 4.23 WIDE BLUE AND CHROME		BNH3699	1
48	HEX HEAD CAP SCREW GR-5 Z/P 3/8-16 X 2		BNH2041	1	96	LABEL-NUMBERS 10-150 LBS/KGS 7/8 X 3 YELLOW & BLACK		BNH3096	1

PRE ASSEMBLED COMPONENTS

Item No.	Description	Rev.	Part No.	Qty.	Item No.	Description	Rev.	Part No.	Qty.
*2	CAM	0	UP8820X1	1	*14	PIVOT AXLE SUPPORT TUBE	0	UP8830X1	2
*3	CAM SUPPORT TUBE	0	UP8821X1	1	*15	RIGHT LEG ARM	0	UP8831X1	1
*4	FLOATING PULLEY BRACKET	0	UP8822X1	1	*20	WEIGHT SHIELD FRONT	0	UP8468X1	1
*6	HANDLES	0	UP8823X1	1	*22	WEIGHT STACK FRAME	0	UP8835X1	1
*8	LEFT LEG ARM	0	UP8825X1	1	*57	PLASTIC SHROUD LID		BNH3393X1	1
*11	MAIN FRAME	0	UP8828X1	1					

Pre-Assembled Components



***22** UP8835X1

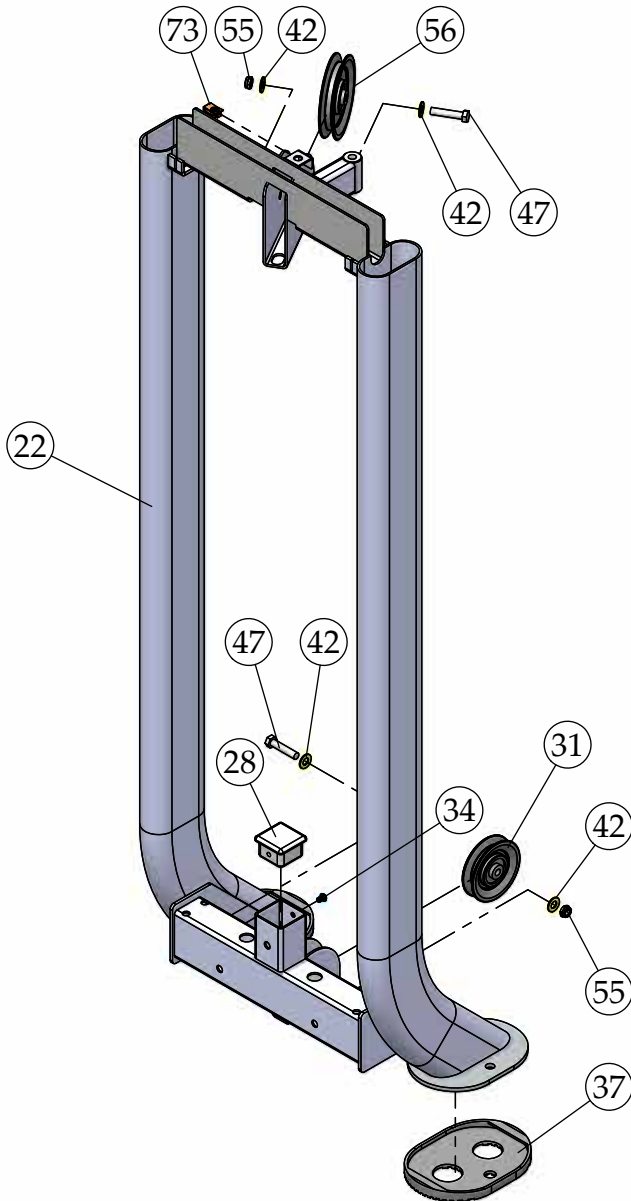

***3** UP8821X1

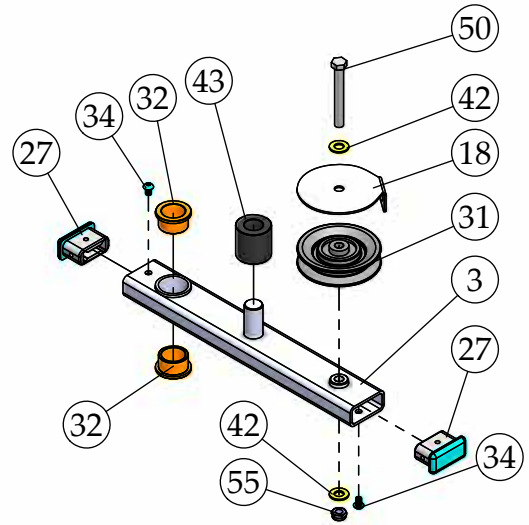

***57** BNH3393X1

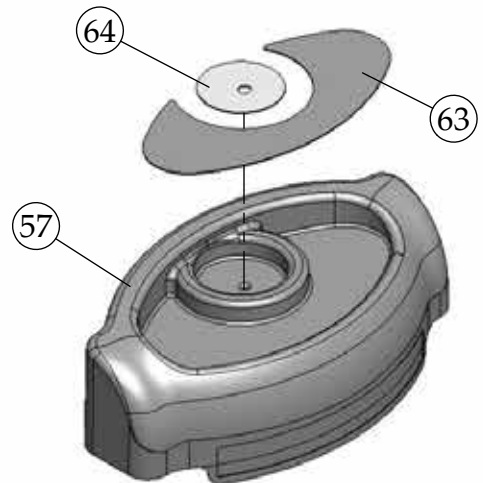

***2** UP8820X1

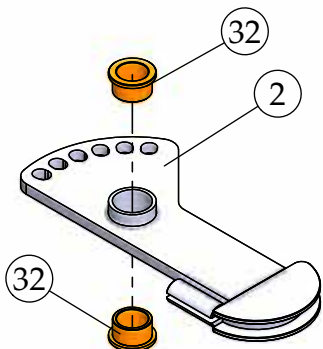

***4** UP8822X1

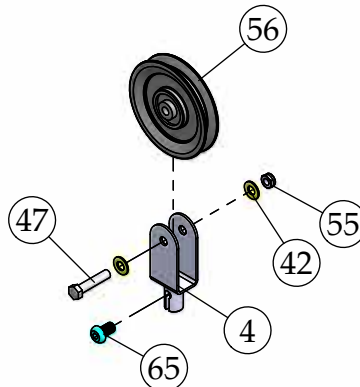

***14** UP8830X1

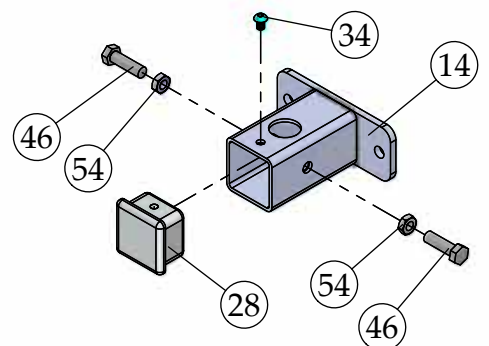

Pre-Assembled Components



*20 UP8468X1

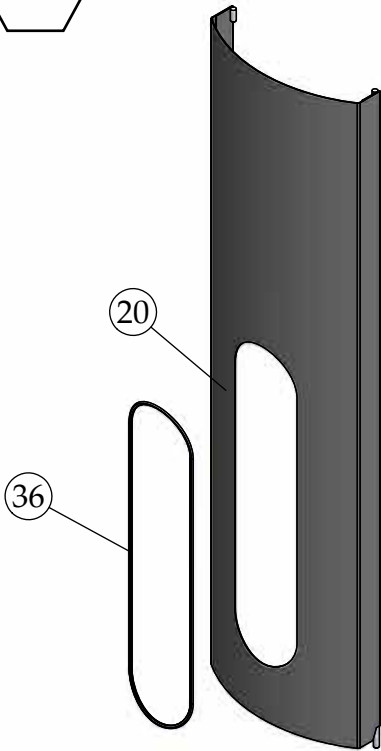

*11 UP8828X1

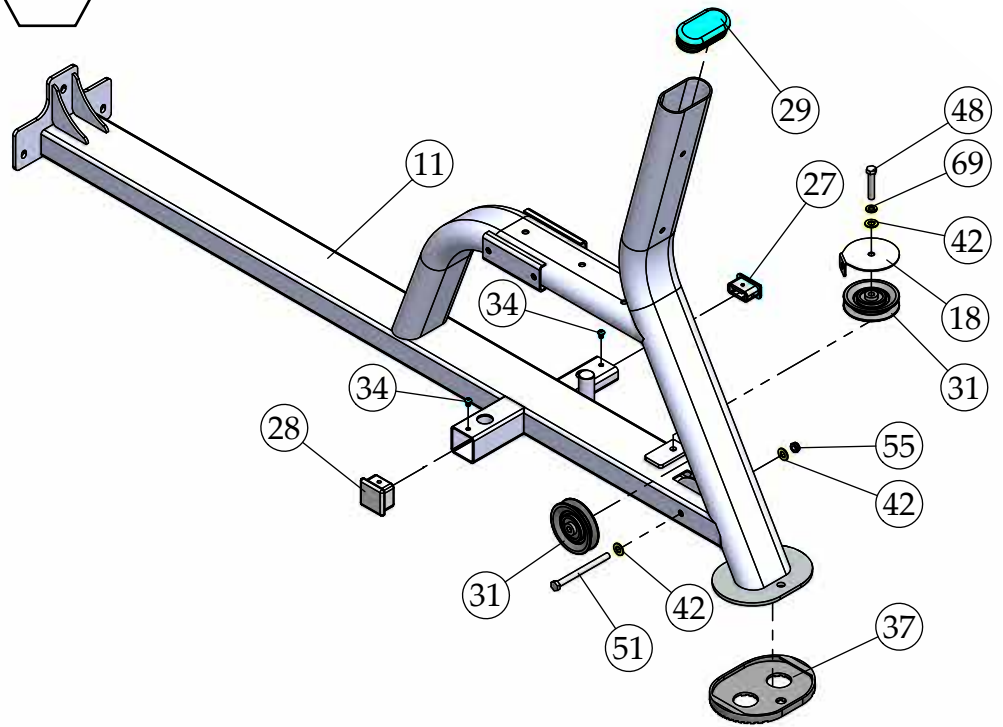

*15 UP8831X1

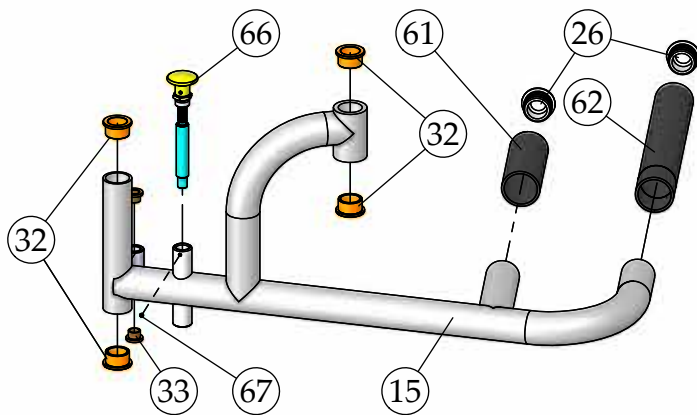

*14 UP8830X1

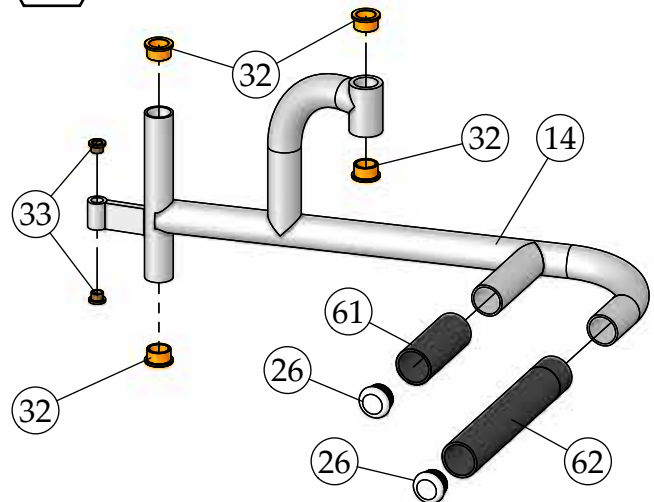

*6 UP8823X1

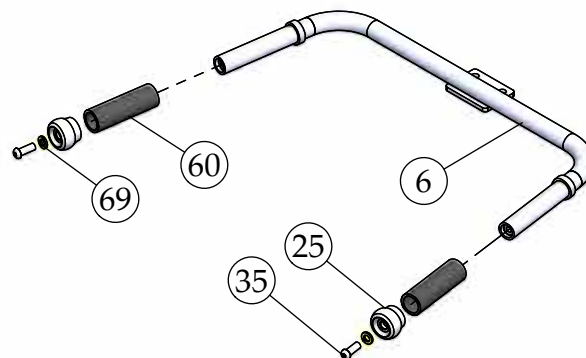



COMMERCIAL WARRANTY*

This warranty applies only in the United States to the products manufactured or distributed by TuffStuff Fitness International Inc. (TFI) under the CALGYM brand name. TFI warrants to the original purchaser that CALGYM equipment will be free from defects in material and workmanship. All warranty periods begin to run from the date of purchase to the original purchaser. The warranty and remedies set forth herein are conditioned upon proper storage, installation, use and maintenance and conformance with any recommendations of TFI. This warranty does not cover products not manufactured by TFI or products which are altered without the express written consent of TFI.

COMMERCIAL WARRANTY*:

TEN (10) YEARS: Frames, welds, cams and weight plates.

FIVE (5) YEARS: Pivot bearings, pulleys, bushings, gas shocks and guide rods.

ONE (1) YEAR: Belts, linear bearings and pull-pin components.

All other parts not mentioned, one (1) year from the date of purchase to the original purchaser.

SIX (6) MONTHS: Upholstery, cables, finish and rubber grips.

***Not recommended for membership based or dues paying facilities.**

The obligation of TFI under this warranty is limited to repairing or replacing warranted defective parts as TFI may elect, at TFI's facility in Chino, California, without charge to the purchaser. Purchaser is responsible for installation of repaired or replaced parts, and all transportation and insurance costs on returned or replaced equipment to and from TFI's facility in Chino.

THE FOREGOING SHALL CONSTITUTE THE SOLE REMEDY OF THE PURCHASER AND THE SOLE LIABILITY OF TFI WITH REGARD TO WARRANTY, WHETHER EXPRESS OR IMPLIED BY OPERATION OF LAW OR OTHERWISE, INCLUDING BUT NOT LIMITED TO ANY IMPLIED WARRANTIES OF MERCHANTABILITY OR FITNESS. TFI SHALL IN NO EVENT BE LIABLE FOR INCIDENTAL OR CONSEQUENTIAL LOSSES, DAMAGES, OR EXPENSES IN CONNECTIONS WITH EXERCISE PRODUCTS. TFI'S LIABILITY HEREUNDER IS EXPRESSLY LIMITED TO THE REPAIRS OR REPLACEMENTS OF WARRANTED DEFECTIVE PARTS.

This written warranty is the final, complete and exclusive agreement of the parties with respect to the quality or performance of the equipment and no action for breach of this written warranty or any implied warranty shall be commenced more than one (1) year after the accrual of the cause of action. No modification of this warranty or waiver of its terms shall be binding on either party unless approved in writing by an authorized representative of the party. Contact TuffStuff Fitness International, Inc. at 13971 Norton Avenue, Chino, CA 91710, before returning any defective equipment.

This warranty gives you specific legal rights and you may also have other rights, which may vary from state to state.

SERIAL #

Write your Serial number here for future reference

_____ Purchase Date



TuffStuff Fitness International, Inc.

13971 Norton Avenue, Chino, CA 91710, USA. Ph 909-629-1600 Fx 909-629-4967

www.tuffstufffitness.com service@tuffstuff.net or service1@tuffstuff.net