



TUFFSTUFF FITNESS INTERNATIONAL

OWNER'S MANUAL

Maintenance & Assembly Instructions

IMPORTANT: KEEP THIS MANUAL FOR FUTURE REFERENCE

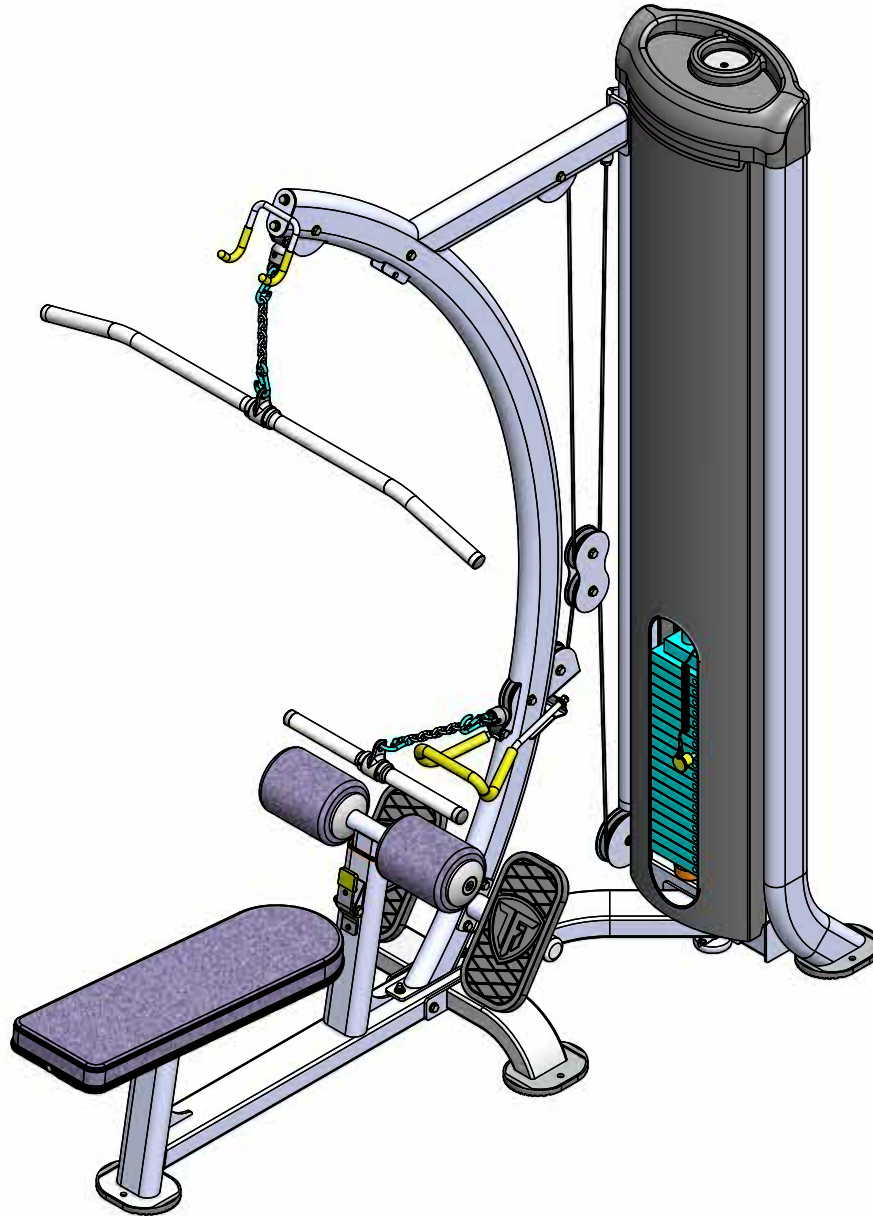

NOTICE

It is the Purchaser's/Owner's obligation:

1. To disclose and post all Rules & Regulations, Danger, Warning and Caution labels affixed on the machine to their customers/users.
2. Equipment to be installed by TFI Authorized Dealer or a service company approved by TFI.
3. Provide trained personnel, supervision and correct usage of the equipment.
4. Provide scheduled inspection, maintenance & repairs and must be performed by TFI Authorized Dealer or a service company approved by TFI.
5. Must use only genuine TFI replacement parts.
6. **▲ WARNING** Machine must be anchored to a solid and level surface.

CG-9504

Lat/Mid Row

Table of Contents



Overhead Specifications.....	Page 3
Danger, Warning, & Caution Labels Information	Page 4-7
Anchoring Unit.....	Page 8
Important Safety Instructions.....	Page 9
Registration, Service & Assembly	Page 10
Inspection/Maintenance	Page 11
Cable Inspection.....	Page 12
Step 1	Page 13
Step 2.....	Page 14
Step 3.....	Page 15
Step 4.....	Page 16-17
Step 5 Cable Routing	Page 18-19
Step 6 Cable Routing	Page 20-21
Step 7	Page 22
Step 8.....	Page 23
Parts List.....	Page 24
Pre-Assembled Components	Page 25-26
Notes.....	Page 27
Warranty	Page 28

TuffStuff Fitness International Inc. continually engages in research related to product improvements. Please take the time to carefully read through this owner's manual thoroughly. Instructions contained in this owner's manual are not intended to cover all details or variations possible with equipment, or to cover every contingency that may be met in conjunction with assembly, installation, operation, maintenance or troubleshooting of the equipment. Even though we have prepared this owner's manual with extreme care, neither the manufacturer nor the author can accept responsibility for any errors in, or omission from, the information given. Should additional information be required, or should situations arise that are not covered by this owner's manual, the matter should be directed to Customer Service at TuffStuff Fitness International Inc. in Chino, California.

Overhead Specifications

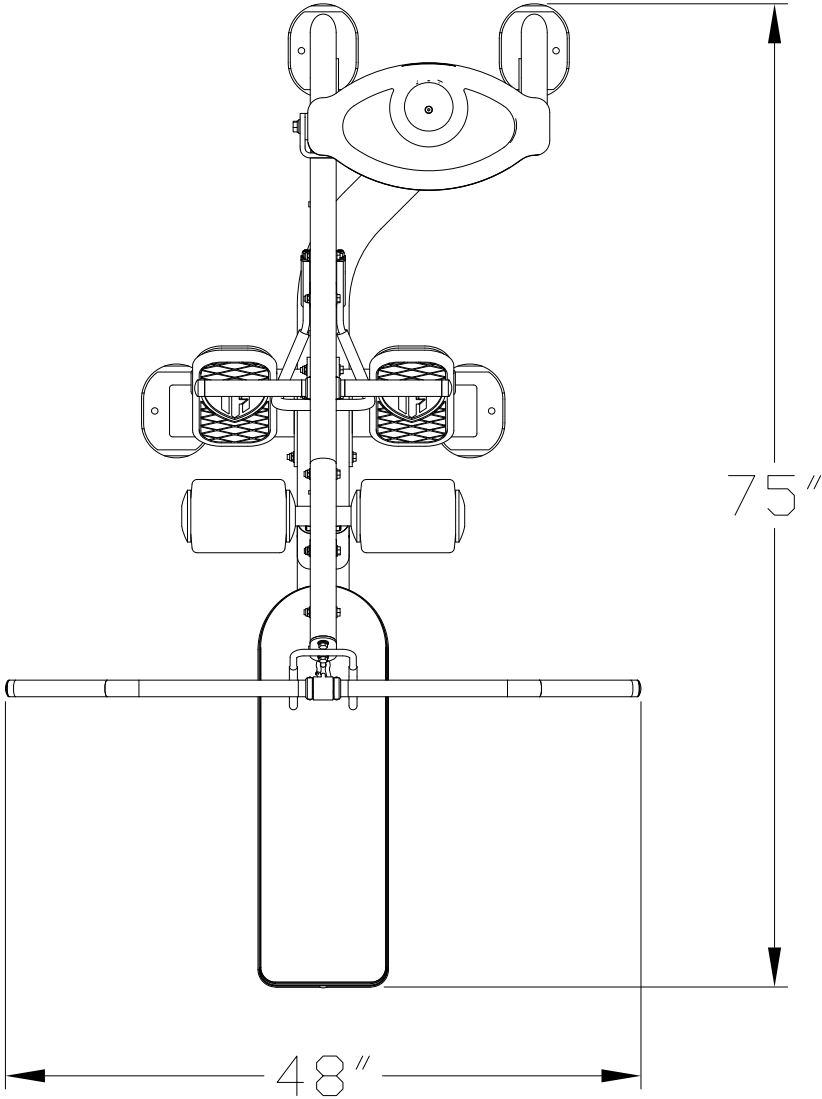

L 75" X W 48" X H 88"
MAX-LOAD WEIGHT LIMIT -200 lbs

Carefully read ALL Danger, Warning & Caution labels posted on the machine

88
WARNING
DO NOT Use for Chinning
(Lat bar holder only)

74
DANGER
Use this equipment ONLY for its intended purpose.
If you are unfamiliar with the equipment or procedure, seek assistance from floor personnel.
Failure to comply could result in serious injury or death.

87
DANGER
DO NOT lean against or pull on the framework, weight stack or any component at all times.
Inappropriate or improper use can cause the machine to tip over, and could result in serious injury or death.

82
WARNING
Keep body, hands and fingers clear of all moving parts.

76
IMPORTANT
ADJUST Cable Tension Here

89
WARNING
Keep body, hands and fingers clear of all moving parts.

90
CAUTION
CHECK Pull-pin is fully engaged in the hole before use.

92
IMPORTANT
For smooth performance, lubricate all gliding surfaces with silicone spray lubricant.

72
CAUTION
Adjust lever to 1/16" above the floor surface.

81
WARNING
Anchor bolt here to fasten the machine to the floor.

20 lbs	9.1 kg
30 lbs	13.6 kg
40 lbs	18.1 kg
50 lbs	22.7 kg
60 lbs	27.2 kg
70 lbs	31.8 kg
80 lbs	36.3 kg
90 lbs	40.8 kg
100 lbs	45.4 kg
110 lbs	49.9 kg
120 lbs	54.4 kg
130 lbs	59.0 kg
140 lbs	63.5 kg
150 lbs	68.0 kg
160 lbs	72.6 kg
170 lbs	77.1 kg
180 lbs	81.6 kg
190 lbs	86.2 kg
200 lbs	90.7 kg

77
IMPORTANT
For smooth performance, clean guide rods with Super Lube® spray lubricant and lubricate with Super Lube® (PTFE) grease.

81
WARNING
Anchor bolt here to fasten the machine to the floor.

INSPECTIONS	Frequency			
	DAILY	WEEKLY	MONTHLY	YEARLY
Recommended Inspection Inspect all parts at first signs of wear or damage.				
INSPECT: Links, pull-pins, strap holes, sleeves, connectors, selector pin, and welded-ports.	X			
CLEAN: Upholstery with lanolin-base cleaner. Do not use Windex.	X			
INSPECT: Cables, bolts and tension (adjust if needed).	X			
INSPECT: All bolts	X			
INSPECT: All nuts and bolts (tighten if needed).	X			
INSPECT: Accessory bars, handles, rubber grips.	X			
INSPECT: All anti-tilt surfaces.	X			
CLEAN & LUBRICATE: Clean guide rods with Super Lube® spray lubricant and lubricate with Super Lube® (PTFE) grease.		X		
LUBRICATE: Self-lubing, pull-pin sliding mechanism, bushings and linear bearings.			X	
CLEAN & WAX: All superficial finishes.				X
REPLACE: Cables & connecting parts.				X

Use only genuine TuffStuff replacement parts. Failure to do so will void warranty and could result in serious injury or death.
TuffStuff Fitness International
China, GA 91710, USA
www.tuffstufffitness.com 8885137

78

84

WARRANTY

COMMERCIAL*

- TEN (10) YEARS:**
 - Frames, welds, cams and weight plates
- FIVE (5) YEARS:**
 - Pivot bearings, rollers, bushings, gas shocks and guide rods
- ONE (1) YEAR:**
 - Bells, linear bearings and pull-pin components

ALL OTHER PARTS not mentioned, one year from the date of delivery to the original purchaser.

SIX (6) MONTHS:

- Upholstery, cables, finish and rubber grips

* Not recommended for membership based or dues paying facilities.

The warranty set forth herein are conditioned upon proper storage, installation, use and maintenance.

All warranty periods begin to run from the date of delivery to the original purchaser. The obligation of TuffStuff under the warranty is limited to repairing or replacing warranted defective parts, as TuffStuff may elect, at TuffStuff's facility in China, California, without charge to the Purchaser for other parts or labor. Purchaser is responsible for installation of repaired or replaced parts, and all transportation and insurance costs to and from TuffStuff's facility in China. For a detailed copy of the warranty, please contact:
TuffStuff Fitness International
China, GA 91710, USA
www.tuffstufffitness.com 8885137

75

Lat/Mid-Row

Lat/Mid-Row is a compound exercise that targets the latissimus dorsi muscle, the largest muscle in the body. It is a multi-joint exercise that involves the shoulder, elbow and wrist joints. The latissimus dorsi muscle is located in the back and runs from the lower back to the upper arm. It is responsible for pulling the arm down and across the body. The latissimus dorsi muscle is also responsible for pulling the arm up and across the body. The latissimus dorsi muscle is a powerful muscle that is used in many sports and activities. It is a key muscle for powerlifters, bodybuilders and athletes. The latissimus dorsi muscle is also a key muscle for posture and balance. The latissimus dorsi muscle is a key muscle for the back and shoulder. The latissimus dorsi muscle is a key muscle for the arm and hand. The latissimus dorsi muscle is a key muscle for the chest and abdomen. The latissimus dorsi muscle is a key muscle for the hip and leg. The latissimus dorsi muscle is a key muscle for the foot and ankle. The latissimus dorsi muscle is a key muscle for the entire body.

TUFFSTUFF FITNESS INTERNATIONAL

80

TUFFSTUFF FITNESS INTERNATIONAL, INC.

1-888-884-8275
www.tuffstufffitness.com

MODEL _____
SERIAL # _____

Carefully read ALL Danger, Warning & Caution labels posted on the machine

83

WARNING

Serious injury or death can occur if these rules and precautions are not observed:

1. Read and Understand Owner's Manual and all DANGER, WARNING and CAUTION labels before using this equipment. If you still need help, seek assistance from floor personnel.
2. Obtain a medical exam before beginning any exercise program.
3. Stop exercising if you feel faint or dizzy. Consult a physician if you are experiencing pain.
4. Inspect equipment prior to use for wear and tear, loose fittings, worn or frayed cables/belts and frame welds. Do not use if it appears damaged or inoperable.
5. Do not attempt to fix or free any jammed parts by yourself. Seek assistance from floor personnel.
6. Use this equipment only for the intended use and for exercise(s) shown in the exercise label.
7. Keep body, clothing and hair clear from all moving parts.
8. Children must not be allowed near this machine. Teenager must be supervised.
9. Make sure the selector pin is completely inserted. Use only the selector pin provided by the manufacturer. If difficulty inserting the pin, seek assistance from floor personnel.
10. Never pin the weights in an elevated position. Do not use the machine if found in this condition. Inform floor personnel immediately.
11. Do not modify selectorized weight stack with any add-on incremental weights or dumbbells, except those with standard factory install.
12. Do not remove labels affixed to the machine. Replace if damaged.

TuffStuff Fitness International
China, CA 91710, USA
BH01134

85

87

DANGER
DO NOT lean against or pull on the framework, weight stack or any component at all times. Improper or improper use can cause the machine to tip over and could result in serious injury or death.
BH01134

95

IMPORTANT
CHECK CABLES
Be sure cables run between the pulleys and working properly.
BH01134

91

SCHEDULE		REPLACEMENT PARTS
	QUANTITY	REPLACEMENT PARTS
Recommended TuffStuff Parts (Replace or as needed)		
Lubricator	X	
Foam Rollers	X	
Cables	X	
Rubber Grips	X	
Nylon Handles	X	
Pull-Pins	X	
Plastic Guides	X	
Weight Selector Pin	X	
Release Strap	X	
Ass. Release Handle	X	
Black Castor Wheels	X	
Buckle Seat Belt	X	
Labels (as needed)		
<small>Use only TuffStuff replacement parts when servicing. Failure to do so will void warranty on product and could result in personal injury.</small>		
TuffStuff Fitness International 13871 Norton Avenue China, CA 91710 BH01134		

81

WARNING
Anchor bolt here to fasten the machine to the floor.
BH01089

86

DANGER
Do Not REMOVE This Safety Bolt.
BH02900

Carefully read ALL Danger, Warning & Caution labels posted on the machine

84

WARRANTY

COMMERCIAL*

TEN (10) YEARS:

- Frames, welds, cams and weight plates

FIVE (5) YEARS:

- Pivot bearings, pulleys, bushings, gas shocks and guide rods

ONE (1) YEAR:

- Belts, linear bearings and pull-pin components

ALL OTHER PARTS not mentioned, one year from the date of delivery to the original purchaser.

SIX (6) MONTHS:

- Upholstery, cables, finish and rubber grips

* Not recommended for membership based or dues paying facilities.

The warranty set forth herein are conditioned upon proper storage, installation, use and maintenance.

All warranty periods begin to run from the date of delivery to the original purchaser. The obligation of TuffStuff under this warranty is limited to repairing or replacing warranted defective parts, as TuffStuff may elect, at TuffStuff's facility in Chino, California, without charge to the Purchaser for either parts or labor. Purchaser is responsible for installation of repaired or replaced parts, and all transportation and insurance costs to and from TuffStuff's facility in Chino. For a detailed copy of the warranty, please contact:

TuffStuff Fitness International
Chino, CA 91710, USA
www.tuffstufffitness.com

BNH3181

91

SCHEDULE

Replacement Parts

Recommended TuffStuff Parts (replace or as needed)	9-MONTH	12-MONTH	15-MONTH	18-MONTH
Upholstery	X			
Foam Rolls	X			
Cables		X		
Rubber Grips		X		
Nylon Handles			X	
Pull-Pins			X	
Plastic Guides			X	
Weight Selector Pin			X	
Abdominal Strap			X	
Adj. Release Handle				X
Black Caster Wheels				X
Buckle Seat/Belt				X
Labels (as needed)				

Use only TuffStuff replacement parts when servicing. Failure to do so will void warranty on product and could result in personal injury.

TuffStuff Fitness International
13971 Norton Avenue
Chino, CA 91710

BNH3135

78

INSPECTIONS

Recommended Inspection	DAILY	WEEKLY	MONTHLY	6-MONTH	YEARLY
Replace all parts at first signs of wear or damage.					
INSPECT: Links, pull-pins, snap locks, swivels, connectors, selector pin, and welded-joints.	X				
CLEAN: Upholstery with Janolin-base cleaner. Do not use Windex.	X				
INSPECT: Cables, Belts and tension (adjust if needed).	X				
INSPECT: All labels		X			
INSPECT: All nuts and bolts (tighten if needed).		X			
INSPECT: Accessory bars, handles, rubber grips.		X			
INSPECT: All anti-skid surfaces.		X			
CLEAN & LUBRICATE: Clean guide rods with Super Lube® spray lubricant and lubricate with Super Lube® (PTFE) grease.			X		
LUBRICATE: Seat sleeves, pull-pin sliding mechanism, bushings and linear bearings.			X		
CLEAN & WAX: All powder-coat finishes.				X	
REPLACE: Cables & connecting parts.					X

Use only genuine TuffStuff replacement parts. Failure to do so will void warranty and could result in serious injury or death.

TuffStuff Fitness International
Chino, CA 91710, USA
www.tuffstufffitness.com

BNH3137

83

WARNING

Serious injury or death can occur if these rules and precautions are not observed:

1. **Read and Understand** Owner's Manual and all DANGER, WARNING and CAUTION labels before using this equipment. If you still need help, seek assistance from floor personnel.
2. Obtain a **medical exam** before beginning any exercise program.
3. **Stop exercising** if you feel faint or dizzy. Consult a physician if you are experiencing pain.
4. **Inspect equipment** prior to use for wear and tear, loose fittings, worn or frayed cables/belts and frame welds. Do not use if it appears damaged or inoperable.
5. **Do not attempt to fix** or free any jammed parts by yourself. Seek assistance from floor personnel.
6. **Use this equipment only for the intended use** and for exercise(s) shown in the exercise label.
7. Keep body, clothing and hair **clear from all moving parts**.
8. **Children must not be allowed** near this machine. Teenager must be supervised.
9. **Make sure the selector pin** is completely inserted. Use only the selector pin provided by the manufacturer. If difficulty inserting the pin, seek assistance from floor personnel.
10. **Never pin the weights in an elevated position.** Do not use the machine if found in this condition. Inform floor personnel immediately.
11. **Do not modify selectorized weight stack** with any add-on incremental weights or dumbbells, except those with standard factory installed.
12. **Do not remove labels** affixed to the machine. Replace if damaged.

TuffStuff Fitness International
Chino, CA 91710, USA

BNH3134

76

IMPORTANT

ADJUST

Cable Tension Here

BNH2924

74

DANGER

Use this equipment ONLY for its intended purpose.

If you are unfamiliar with the equipment or procedure, seek assistance from floor personnel.

Failure to comply could result in serious injury or death.

BNH3088

87

DANGER

DO NOT lean against or pull on the framework, weight stack or any component at all times.

Inappropriate or improper use can cause the machine to tip over, and could result in serious injury or death.

BNH3145

95

IMPORTANT

CHECK CABLES

Be sure cables run between the pulleys and working properly.

BNH3113

92

IMPORTANT

For smooth performance, lubricate all gliding surfaces with silicone spray lubricant.

BNH2916

90

CAUTION

CHECK

Pull-pin is fully engaged in the hole before use.

BNH2912

86

DANGER

Do Not REMOVE This Safety Bolt.

BNH2906

77

IMPORTANT

For smooth performance, clean guide rods with Super Lube® spray lubricant and lubricate with Super Lube® (PTFE) grease.

BNH2925

80

TUFFSTUFF FITNESS INTERNATIONAL, INC.

1-888-884-8275

www.tuffstufffitness.com

MODEL _____

SERIAL # _____

BNH3147

72

CAUTION

Adjust leveler to 1/16" above the floor surface.

LEVELER – adjust here

BNH2967

Carefully read ALL Danger, Warning & Caution labels posted on the machine

73



82



88



81

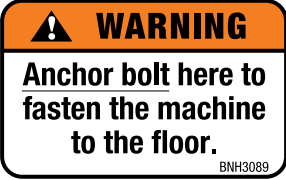

75

Lat/Mid-Row

- Select appropriate weight resistance for your present fitness level.
- Adjust the thigh hold-down pad. Grasp the lat bar and sit down placing your thighs under the pads.
- Lean back slightly, slowly pull lat bar down to the top your chest.
- Return weight under control to starting position and repeat as desired.

LAT PULLDOWN:

- Place feet on the foot support, grasp bar and bring to start position with cable taut.
- Slowly pull bar to the mid section keeping your elbows as far back as possible.

MID-ROW:

- Place feet on the foot support, grasp bar and bring to start position with cable taut.
- Slowly pull bar to the mid section keeping your elbows as far back as possible.

Safety Tips

- Read all caution and warning labels posted on the machine. Seek assistance from staff familiar with the machine or its use.
- It is important to know your own physical condition before beginning any type of exercise program.
- Always choose a light resistance when using a machine the first time.
- Lean at a controlled rate or speed.
- Never hold your breath—inhaling during least resistant and exhaling at maximum resistance.
- Warm-up with light cardio exercises, stretching or calisthenics.

WARNING
If the machine appears to be damaged or inoperable, DO NOT use. Inform floor personnel immediately.

www.tuffstufffitness.com

TUFFSTUFF FITNESS INTERNATIONAL

79

TOP PLATE 10 lbs.	TOP PLATE 4.5 kgs.
20 lbs.	9.1 kgs.
30 lbs.	13.6 kgs.
40 lbs.	18.1 kgs.
50 lbs.	22.7 kgs.
60 lbs.	27.2 kgs.
70 lbs.	31.8 kgs.
80 lbs.	36.3 kgs.
90 lbs.	40.8 kgs.
100 lbs.	45.4 kgs.
110 lbs.	49.9 kgs.
120 lbs.	54.4 kgs.
130 lbs.	59.0 kgs.
140 lbs.	63.5 kgs.
150 lbs.	68.0 kgs.
160 lbs.	72.6 kgs.
170 lbs.	77.1 kgs.
180 lbs.	81.6 kgs.
190 lbs.	86.2 kgs.
200 lbs.	90.7 kgs.

89



85



71

BE ALERT!

THE FITNESS EQUIPMENT IN THIS FACILITY PRESENTS HAZARDS WHICH, IF NOT AVOIDED, COULD CAUSE SERIOUS INJURY OR DEATH.

Prior to using the equipment, READ the warning labels and instruction placards affixed to each machine.

If you are unsure on how to use a machine, seek the assistance of our floor personnel. We will be happy to instruct you on how to use the equipment properly.

Immediately report any piece of equipment that is not functioning properly to our floor personnel so that it may be evaluated and service promptly.

DO NOT ATTEMPT to use or fix any piece of equipment that is not functioning properly.

ASTM F1749-96 TUFFSTUFF FITNESS INTERNATIONAL, CHINO, CA 91710
BNH3138

It is extremely important that the **Facility Sign** shown to the left be installed in plain view of the unit.

You should have received it along with this Owner's Manual. If you did not receive this Facility Sign with your order, you can obtain one at no cost to you from TuffStuff Fitness by contacting our service department at:

1 (888) 884-8275
service@tuffstuff.net
service1@tuffstuff.net

Anchoring Unit

Holes on frame are provided for anchoring the unit to the floor. See anchoring hole location below.

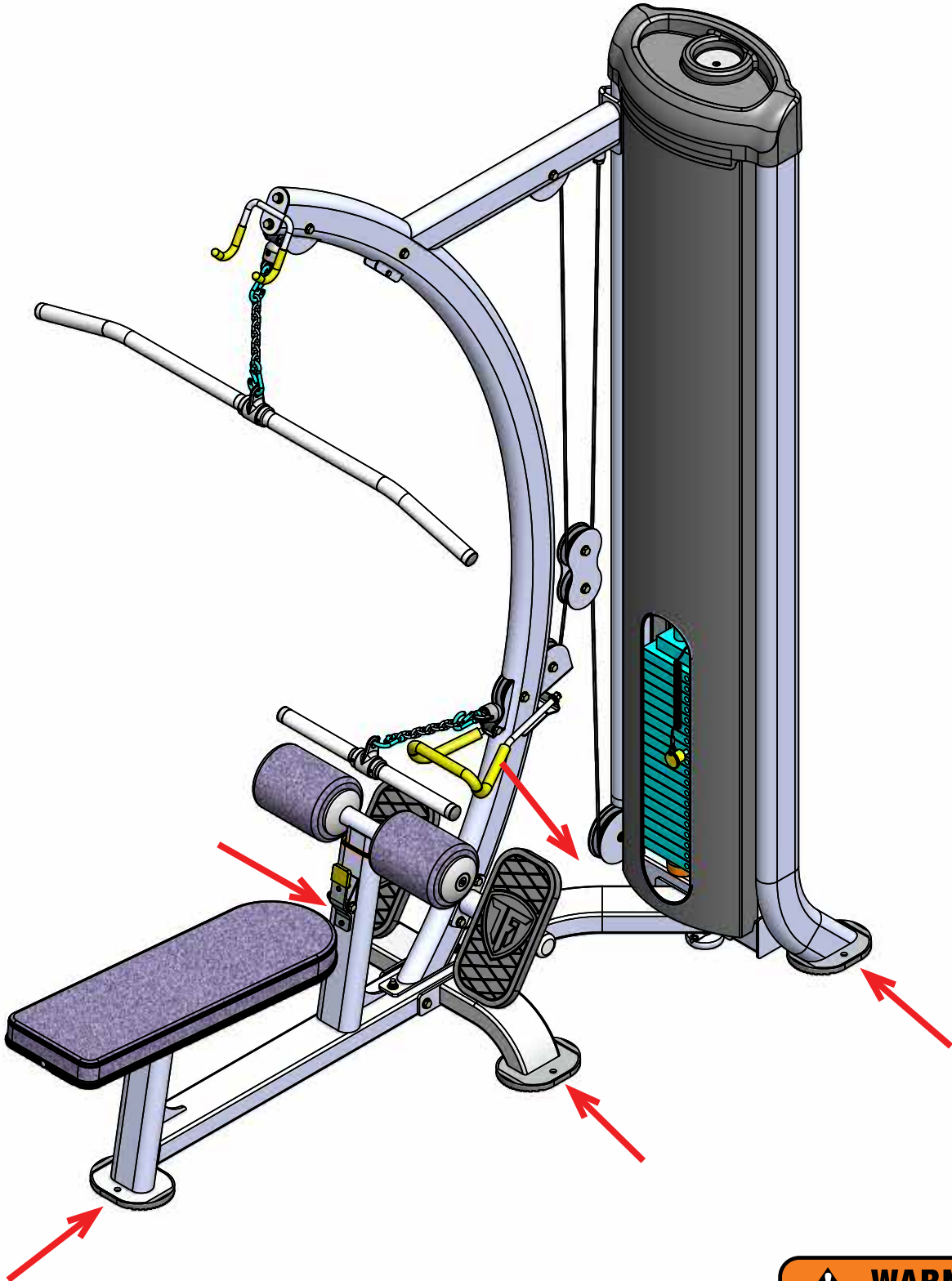

⚠ WARNING
Anchor bolt here to fasten the machine to the floor.

BNH3089

Important Safety Instructions



It is the responsibility of the facility owner and/or owner of the equipment to review the Owner's Manual with their facility personnel and understand all Danger, Warning and Caution labels affixed on the machine. It is the responsibility of the floor personnel to instruct users on proper operation of the equipment and review all danger, warning and caution labels.

⚠ WARNING SERIOUS INJURY OR DEATH CAN OCCUR IF THESE SAFETY PRECAUTIONS ARE NOT OBSERVED:

1. Obtain a medical exam before beginning any exercise program.
2. Read and understand Owner's Manual and all **Danger, Warning and Caution** labels before using this equipment. If you still need help, seek assistance from floor personnel.
3. **Inspect the equipment** before each use for wear and tear, loose fittings, worn or frayed cables and frame welds. **DO NOT USE** if it appears to be inoperable or damaged.
4. Stop exercising if you feel faint or dizzy. Consult a physician if you are experiencing pain.
5. **Use this equipment only for the intended use.**
6. Keep body, clothing and hair clear from all moving parts. Do not attempt to free any jammed parts by yourself.
7. Always warm-up before and cool-down after weight training. Warm-up for 10-15 minutes with stretching and cardiovascular exercises. Cool-down should include light stretching exercises for 5-15 minutes.
8. Never hold your breath – will limit the flow of oxygen to your brain and may cause dizziness. The most often used breathing pattern is inhaling during least resistance and exhaling during maximum resistance.
9. Do not use accessories or accessory attachments that are not recommended by TFI.
10. Make sure selector pin is completely inserted. Use only the selector pin provided by the manufacturer.
11. Never pin the weights in an elevated position. Do not use the machine if found in this condition.
5. Provide an adequate safety perimeter between the machine, walls and other equipment to ensure that the facility has proper clearance for usage and training.
6. Post and disclose all safety, rules and regulations on a bulletin board easily accessible to users.
7. Perform regular maintenance (see Inspection Label). Pay special attention to areas most susceptible to wear and tear, including but not limited to cables, pulleys and rubber grips.
8. **Do not** lean against or pull on the framework, weight stack or any component at all times.
9. **Children must not** be allowed near the equipment. Teenager must be supervised.
10. Replace immediately all parts at first sign of wear or damage. If unable to replace worn or damaged components/parts, remove machine from service until the repair is made.
11. Use only genuine TuffStuff replacement parts. Failure to do so will void warranty and could result in serious injury or death to the users.
12. **Do not remove** any decals affixed to the machine. Replace if damaged.
13. **Do not alter or modify** the original manufacturer's weight stack with any add-on incremental weights, weight plates or dumbbells except those with standard factory installed option.
14. Maintain a service contract with a TFI Authorized Dealer or a Professional Service Company approved by TFI. Keep a service log of all maintenance and repair activities. **NOTICE:** It is the sole responsibility of the owner or facility operator to ensure that regular maintenance is performed.

Facility Safety Guidelines and Practices

1. Read and understand the Owner's Manual before assembling, servicing or using the equipment.
2. Equipment to be installed by TFI Authorized Dealer or Professional Service Company approved by TFI.
3. Make sure each machine is set up and operated on a solid level surface. Do not install equipment on an uneven surface.
4. **Anchoring of equipment must be completed** at time of installation and inspected prior to use. Failure to anchor the machine to the floor could cause the machine to tip or fall over due to incorrect usage and misuse, and could result in serious injury or death.



DANGER: indicates an imminently hazardous situation which, if not avoided, will result in death or serious injury.



WARNING: indicates a potentially hazardous situation which, if not avoided, will result in death or serious injury.



CAUTION: indicates a hazardous situation which, if not avoided, could result in minor or moderate injury.

Registration, Service & Assembly



Thank you for purchasing the CG-9504 Lat/Mid Row. This machine is part of the TuffStuff line of quality strength training equipment. To maximize your use of the equipment, please study the Owner's Manual thoroughly.

Registration

To avoid unnecessary delays on warranty parts and to insure that a permanent record of your purchase is on file with our company, be sure to register online at <http://www.tuffstufffitness.com> or mail to address shown below within 10 days of purchase.

Obtaining Service

Please use this Owner's Manual as your guide to all parts included in your shipment. When ordering parts, you must specify the part number and description from this owner's manual. **Use only genuine TuffStuff replacement parts when servicing the equipment.** Failure to do so will void warranty and could result in serious injury or death.

For information about product operation or service:

Phone: 909-629-1600 Toll Free 888-884-8275
Fax: 909-629-4967
E-mail: service@tuffstuff.net or service1@tuffstuff.net
Hours: M-F 8:00 – 4:30 PST
Or write to: TuffStuff Fitness International, Inc.
Customer Service
13971 Norton Avenue, Chino, CA 91710

Retain this Owner's Manual for future reference when ordering service or parts. To assist you better, please be prepared to provide the following information:

1. Model Number
2. Place of Purchase
3. Serial Number
4. Part # and Description

Required Tools

The basic tools that you will need to assemble the CG-9504 but are not limited to:

- 3/4", 9/16", 7/16" combination wrenches
- Adjustable wrench
- Ratchet wrench with 3/4", 9/16", 7/16" sockets
- Rubber mallet, measuring tape & utility knife
- Super Lube® spray lubricant and grease
- Windex or household glass cleaner

Assembly Requirements

Follow these installation requirements when assembling the CG-9504. Use the overhead view on the Content Page to layout your floor plan before assembling.

Set up the CG-9504 on a clean, solid, flat surface. A smooth, flat surface under the machine helps keep it level.

Allow ample space around the machine for safe unrestricted use and easier access.

Insert all bolts in the same direction. For aesthetic appearance, insert all bolts in the same direction unless specified (in text or illustration) to do otherwise.

Leave room for adjustments. Do not fully tighten fasteners until instructed in the assembly steps to do so (to prevent any difficulty with alignment of parts during the assembly process). When not instructed, tighten fasteners such as bolts, nuts and screws so the unit is stable, but leave room for adjustments.

Assembly Tips

Read all "Notes" on each page before beginning each step.

While you may be able to assemble the CG-9504 using the illustrations only, IMPORTANT safety notes and other tips are included in the text.

Some pieces may have extra holes that you will not use. Use only those holes indicated in the instructions and illustration.

NOTE: With so many assembled parts, proper alignment and adjustment is critical. While tightening the nuts and bolts, be sure to leave room for final adjustments.

CAUTION: Obtain assistance from TFI if you have difficulty assembling the CG-9504. Please do not attempt to complete the assembly as this could result in equipment failure and serious injuries to the users.

Symbols & Description

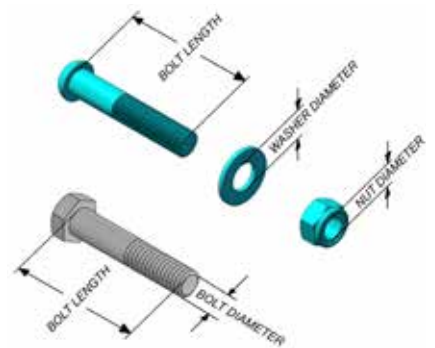

Loosely Tighten

70%

Fully Tighten

100%

Loosely Tighten

Loosely tighten all hardware in this step. DO NOT Fully Tighten. Some component(s) may need pre-assembly and or alignment during the assembly process.

Fully Tighten

Wrench tighten all hardware in this step.

Inspection/Maintenance



Perform regular maintenance (see Inspection Label). Pay special attention to areas most susceptible to wear and tear, including but not limited to cables, pulleys and rubber grip. TFI recommends you maintain a service contract with a TFI Authorized Dealer or a Professional Service Company approved by TFI. Keep a service log of all maintenance and repair activities. Extra copies can be downloaded from our website www.tuffstufffitness.com

INSPECTIONS					
Recommended Inspection Replace all parts at first signs of wear or damage.	DAILY	WEEKLY	MONTHLY	6-MONTH	YEARLY
INSPECT: Links, pull-pins, snap locks, swivels, connectors, selector pin, and welded-joints.	X				
CLEAN: Upholstery with lanolin-base cleaner. Do not use Windex.	X				
INSPECT: Cables, Belts and tension (adjust if needed).	X				
INSPECT: All labels		X			
INSPECT: All nuts and bolts (tighten if needed).		X			
INSPECT: Accessory bars, handles, rubber grips.		X			
INSPECT: All anti-skid surfaces.		X			
CLEAN & LUBRICATE: Clean guide rods with Super Lube® spray lubricant and lubricate with Super Lube® (PTFE) grease.			X		
LUBRICATE: Seat sleeves, pull-pin sliding mechanism, bushings and linear bearings.			X		
CLEAN & WAX: All powder-coat finishes.				X	
REPLACE: Cables & connecting parts.					X

Use only genuine TuffStuff replacement parts. Failure to do so will void warranty and could result in serious injury or death.

TuffStuff Fitness International
Chino, CA 91710, USA
www.tuffstufffitness.com BNH3137

INSPECTION / MAINTENANCE RECORDS			
DATE	REPLACEMENT	REPAIRS	INSPECTED BY
WARRANTY REPAIRS			
DATE	REPLACEMENT	REPAIRS	INSPECTED BY



WARNING:

THE FOLLOWING CONDITIONS MAY INDICATE A WORN CABLE. REPLACE IMMEDIATELY.



"NECKING", STRETCHED CABLE COVERING



A CRACK IN THE CABLE COVER



A TEAR IN THE CABLE COVER



A BREAK ON THE CABLE



CABLE END SLIPPING OUT

IMPORTANT NOTE:

DAMAGED OR WORN CABLE (AS SHOWN ABOVE) MAY DAMAGE THE PULLEY(S). YOU MUST INSPECT THE PULLEYS AT THIS TIME FOR WEAR AND TEAR. REPLACE IF NEEDED.

Step 1



Step 1 Assembly List

Item #	Description	Qty.
*12	MAIN FRAME	1
*18	WEIGHT STACK FRAME	1
33	FLAT WASHER SAE Z/P 3/8"	4
39	HEX HEAD CAP SCREW GR-5 Z/P 3/8-16 X 3	2
45	NYLON INSERT THIN PATTERN LOCK NUT Z/P 3/8-16	2

NOTE:

1. It is strongly recommended that 2 people participate in the assembly of this unit.
2. Be sure to hold the weight stack frame perpendicular to floor before tightening the screws.

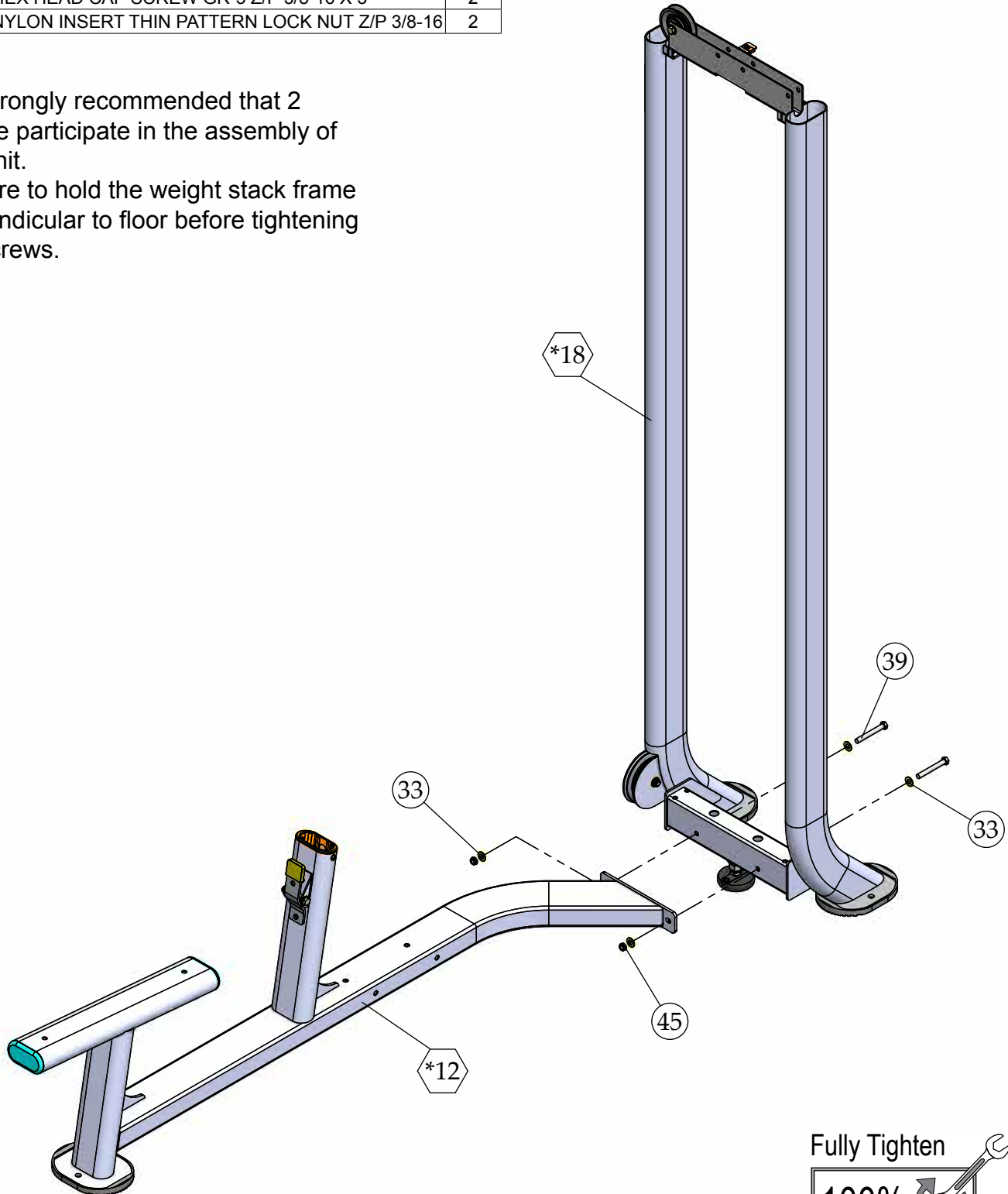

Fully Tighten

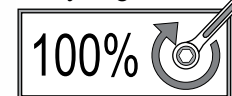

Fully Tighten

Wrench tighten all hardware in this step.

Step 2



Step 2 Assembly List		
Item #	Description	Qty.
*6	FRONT UPRIGHT	1
*8	LAT BAR HOLDER	1
33	FLAT WASHER SAE Z/P 3/8"	4
35	HEX HEAD CAP SCREW GR-5 Z/P 3/8-16 X 1	2
39	HEX HEAD CAP SCREW GR-5 Z/P 3/8-16 X 3	2
45	NYLON INSERT THIN PATTERN LOCK NUT Z/P 3/8-16	2
59	SPLIT LOCK WASHER Z/P 3/8"	2
60	SPLIT LOCK WASHER Z/P 1/2"	2
65	FLAT WASHER SAE Z/P 1/2"	2
66	HEX HEAD CAP SCREW GR-5 Z/P 1/2-13 X 1 1/4	2
67	FLAT WASHER 3/8 ID X 1 1/2 OD X 3/16 THICK	2

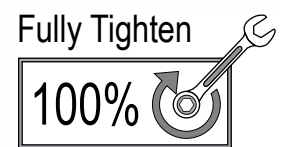
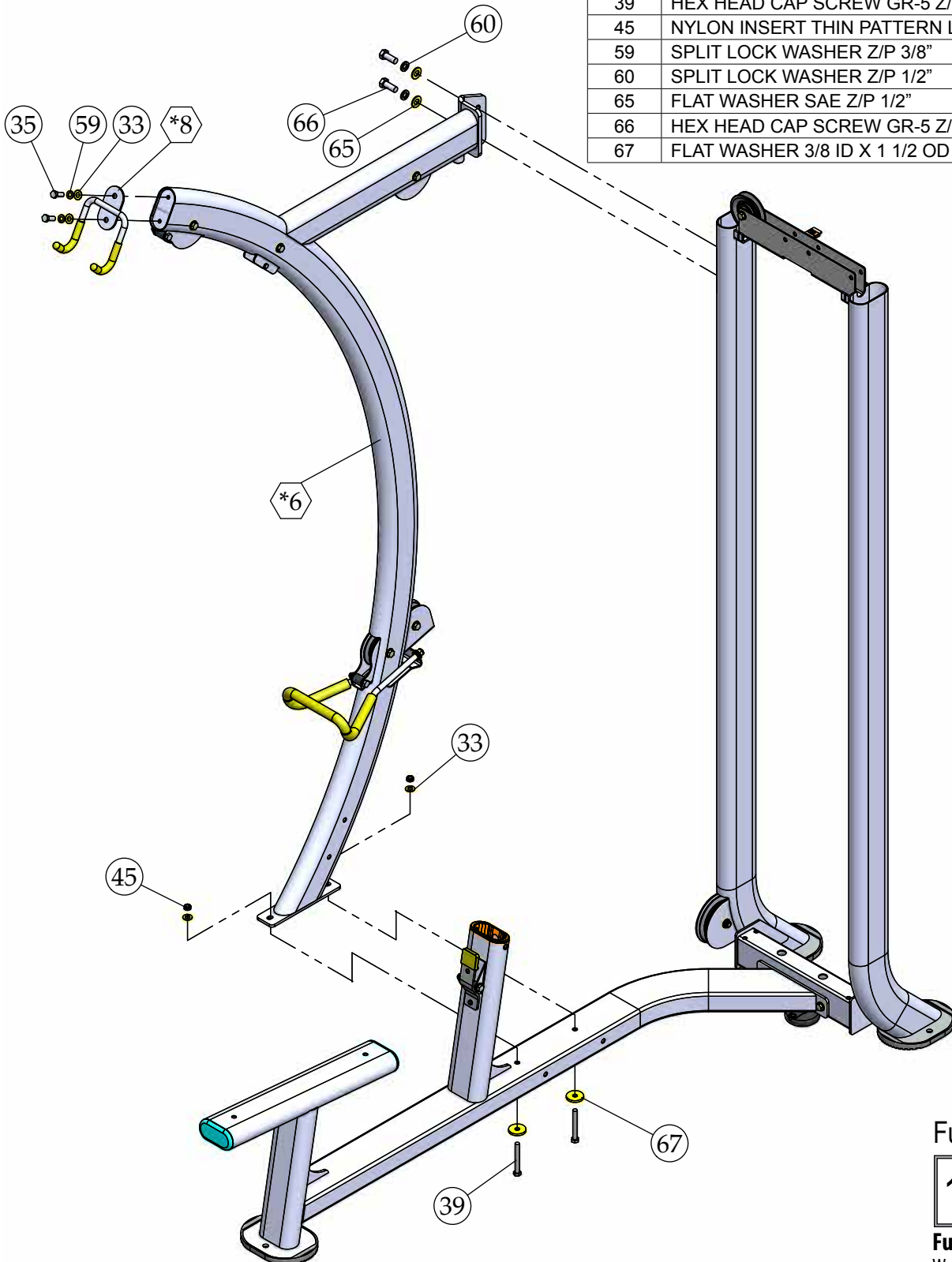

Fully Tighten
Wrench tighten all hardware in this step.

Step 3



Step 3 Assembly List

Item #	Description	Qty.
*5	FOOT PLATE	1
*15	STABILIZER	2
33	FLAT WASHER SAE Z/P 3/8"	8
39	HEX HEAD CAP SCREW GR-5 Z/P 3/8-16 X 3	2
40	HEX HEAD CAP SCREW GR-5 Z/P 3/8-16 X 5	2
45	NYLON INSERT THIN PATTERN LOCK NUT Z/P 3/8-16	4
86	LABEL DANGER DO NOT REMOVE... 7/8 X 1-1/2	1
*100	FOOT PLATE	1

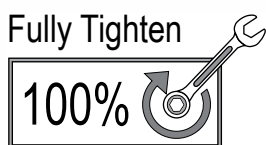
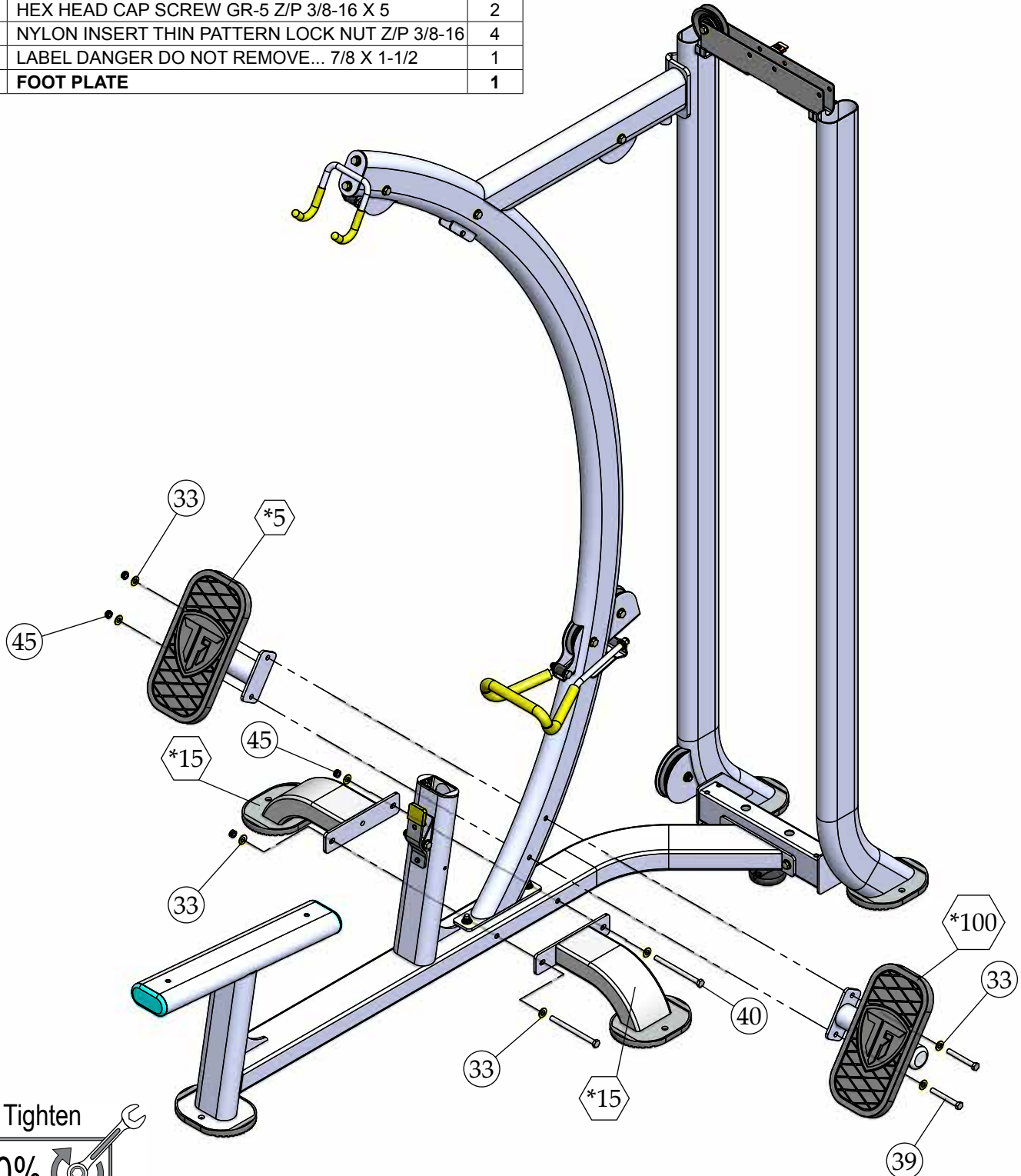

Fully Tighten
Wrench tighten all hardware in this step.

Step 4



Step 4 Assembly List

Item #	Description	Qty.
7	GUIDE ROD 3/4 RD X 76 1/4 (CG-9500 SERIES)	2
14	SELECTOR PIN W/COIL 3/8 X4 GOLD KNOB	1
26	BLACK NYLON PULLEY 3/8 X 1 X 3 1/2 (P-35375-H)	1
33	FLAT WASHER SAE Z/P 3/8"	4
36	HEX HEAD CAP SCREW GR-5 Z/P 3/8-16 X 1 1/4	2
37	HEX HEAD CAP SCREW GR-5 Z/P 3/8-16 X 1 3/4	1
45	NYLON INSERT THIN PATTERN LOCK NUT Z/P 3/8-16	1
52	RUBBER DONUT 3/4 X 2 1/2	4
59	SPLIT LOCK WASHER Z/P 3/8"	2
68	10 LB STEEL WEIGHT PLATE BLACK 4 X 10	19
69	10 LB TOP PLATE W/ADJ SLTR BAR 19 BLK WTS ASM	1

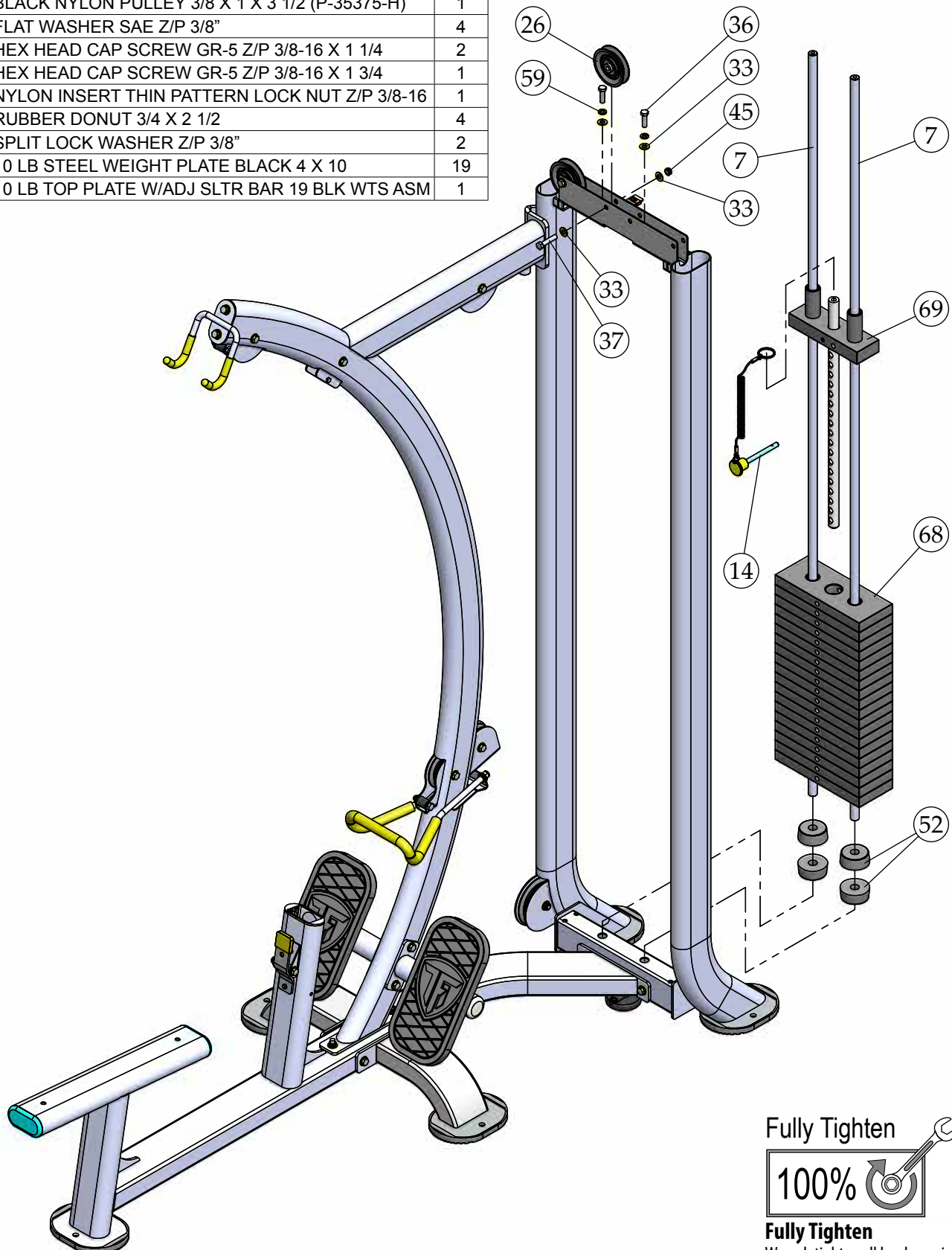

Fully Tighten



Fully Tighten

Wrench tighten all hardware in this step.



NOTE:

1. TOP PLATE LABEL GOES ON HOLE OFF CENTER AS SHOWN. LABEL WILL COVER HOLE ON CENTER.

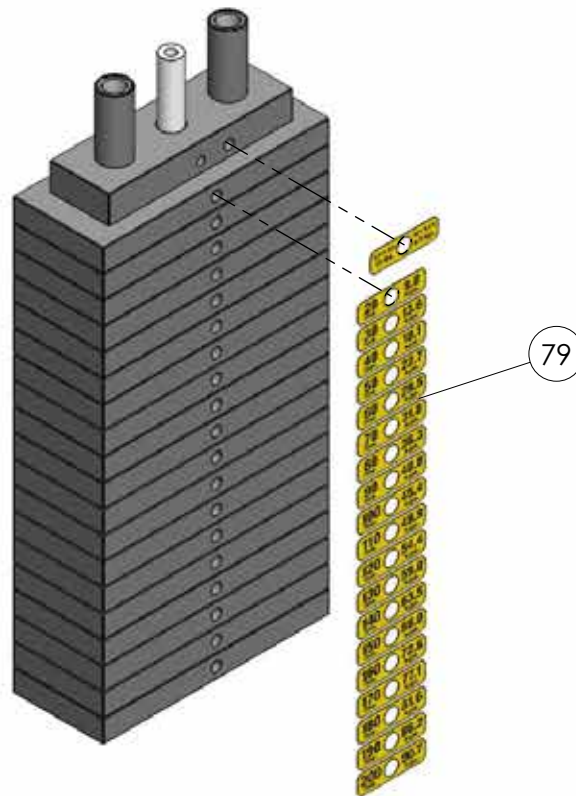

Weight stack label and lubrication instructions

1. Wipe front surface of weight stack with rubbing alcohol and wipe dry.
2. Peel off back sheet (adhesive side) from label (#79) and make sure that the label remains attached to the application tape.
3. Line up left edge of label sheet with outside edge of weight holes.
4. Line up the first label to hole on top plate.
5. Make sure label is straight and slowly press into place.
6. Gently remove application tape and rub each label firmly against the weight stack.
7. Allow labels to stand for 2 days to allow adhesive to cure fully.
8. Open the lube package provided and apply a thin film of lubricant around the first 3 inches of the guide rods above the top plate.
9. After the cables are installed, do a set of reps to spread the lubricant thoroughly.

Step 5 Cable Routing

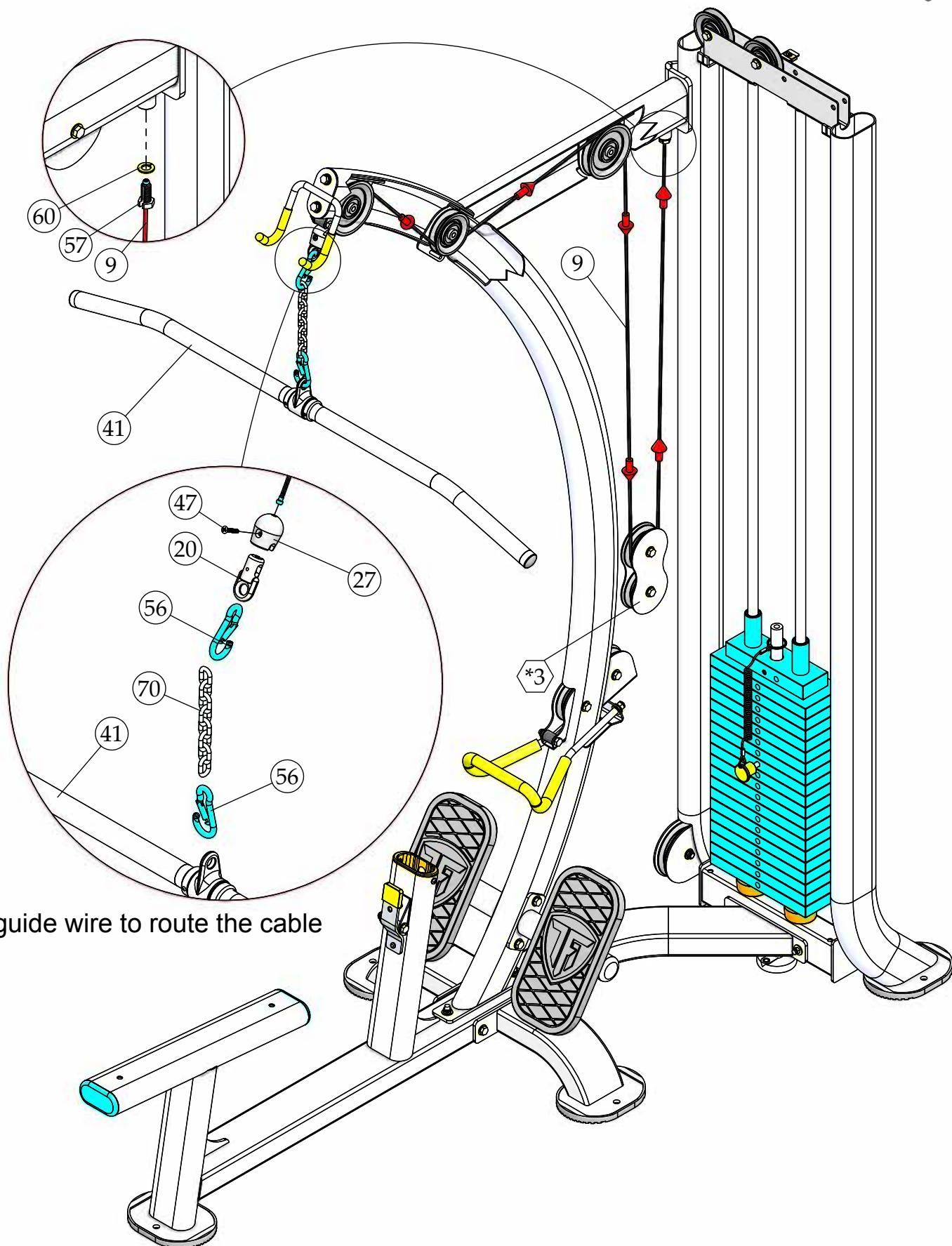

Use guide wire to route the cable

Step 5 Assembly List

Item #	Description	Qty.
*3	DOUBLE PULLEY PLATE	1
9	LAT CABLE	1
20	7/8 RD X 2 15/32 LINK 3/16 CABLE	1
27	CABLE STOPPER SHELL SØ1.5 X 1.75	1
41	LAT BAR 1 1/4 ALUMINUM	1
47	OVAL HEAD SCREW Z/P #10-24 X 1 1/8	1
56	SNAP LINK Z/P 8MM X 80MM	2
57	SPLIT BOLT GR-5 Z/P 1/2-13 X 1 1/4 (RND CUT)	1
60	SPLIT LOCK WASHER Z/P 1/2"	1
70	COIL CHAIN Z/P 3/16 X 8	1

Fully Tighten

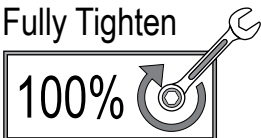

Fully Tighten

Wrench tighten all hardware in this step.

Step 6 Cable Routing

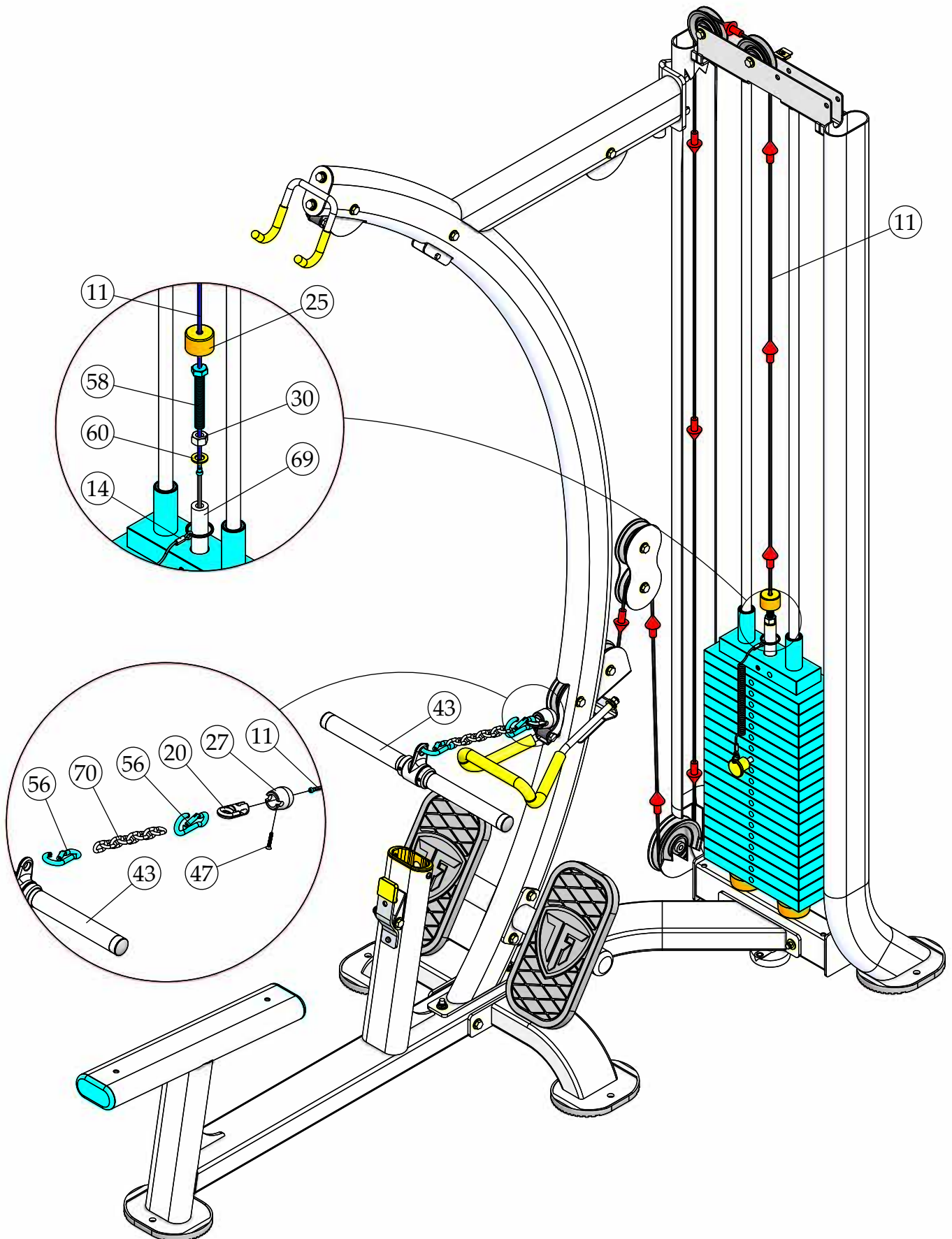



Step 6 Assembly List

Item #	Description	Qty.
11	LOW ROW CABLE	1
14	SELECTOR PIN W/COIL 3/8 X4 GOLD KNOB	1
20	7/8 RD X 2 15/32 LINK 3/16 CABLE	1
25	BLACK NYLON BUMPER	1
27	CABLE STOPPER SHELL SØ1.5 X 1.75	1
30	FINISHED HEX NUT B-Z/P 1/2-13	1
43	LOW ROW BAR 1 1/4 ALUMINUM	1
47	OVAL HEAD SCREW Z/P #10-24 X 1 1/8	1
56	SNAP LINK Z/P 8MM X 80MM	2
58	SPLIT BOLT GR-8 Z/P 1/2-13 X 3 1/2 (RND CUT)	1
60	SPLIT LOCK WASHER Z/P 1/2"	1
70	COIL CHAIN Z/P 3/16 X 8	1

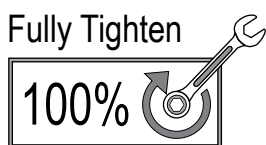

Fully Tighten

Wrench tighten all hardware in this step.

Step 7



Step 7 Assembly List

Item #	Description	Qty.
*16	WEIGHT SHIELD FRONT 75 3/8"	1
17	WEIGHT SHIELD REAR 75 3/8"	1
32	FLAT HEAD SOCKET CAP SCREW Z/P M6-1.0 X 50	1
*49	PLASTIC SHROUD LID	1

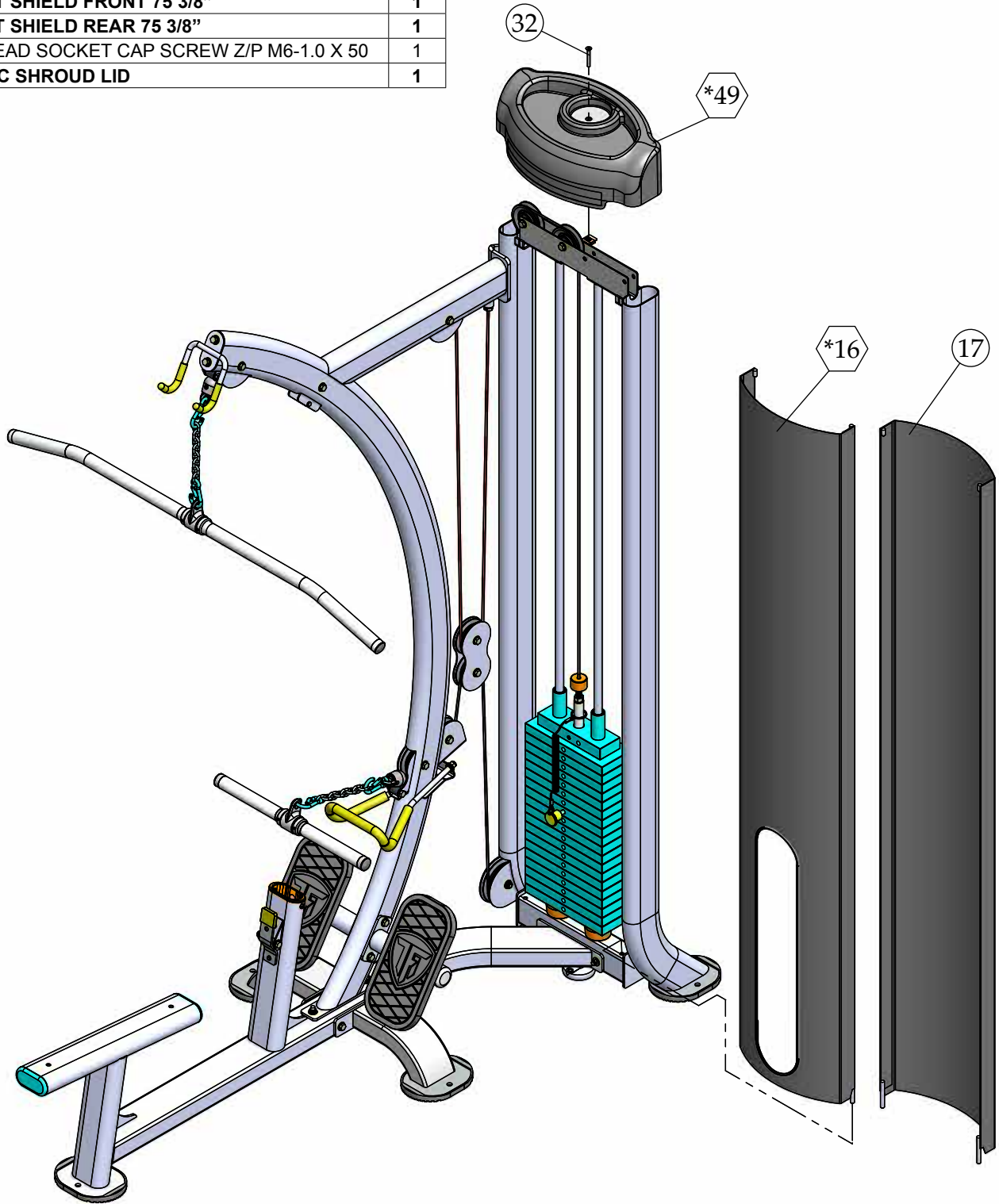

Fully Tighten

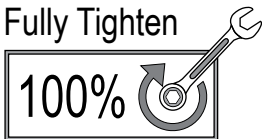

Fully Tighten

Wrench tighten all hardware in this step.

Step 8



Step 8 Assembly List

Item #	Description	Qty.
2	ADJUSTABLE TUBE	1
4	FOAM ROLL 1 X 5 1/2 X 7 1/4	2
13	SEAT PAD	1
19	HEX HEAD CAP SCREW GR-5 Z/P 3/8-16 X 3/4	1
21	ALUMINUM CAP WASHER 1 1/2	2
22	ALUMINUM FOOT ROLL CAP 1" ID	4
31	FLAT HEAD SOCKET CAP SCREW Z/P 3/8-16 X 1	2
33	FLAT WASHER SAE Z/P 3/8"	2
39	HEX HEAD CAP SCREW GR-5 Z/P 3/8-16 X 3	2

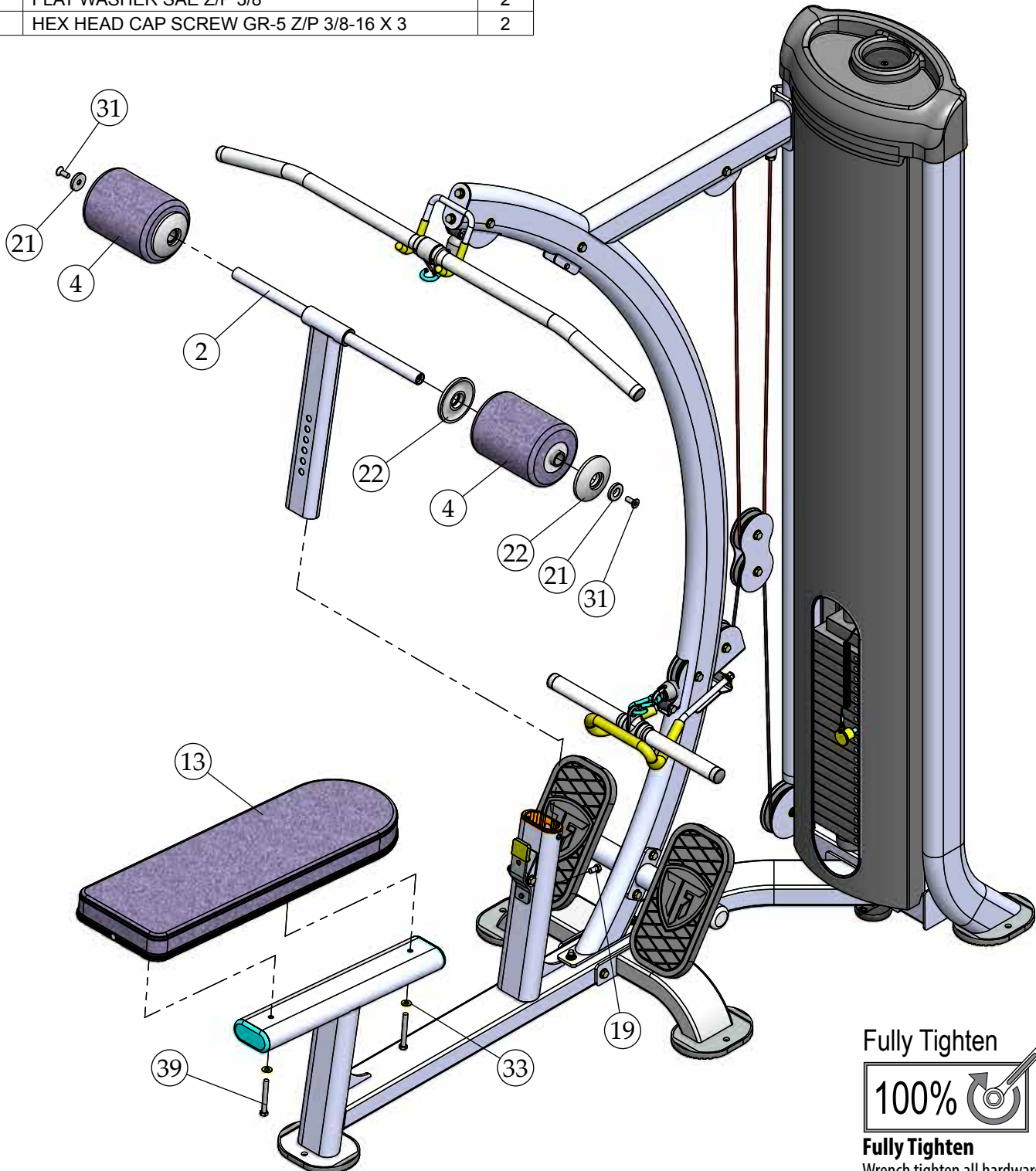

Fully Tighten

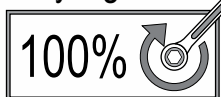

Fully Tighten

Wrench tighten all hardware in this step.

Parts List



COLOR CHART
 GRAY= SUB-ASSEMBLY PARTS
 BLACK= HARDWARE

CG-9504 Parts List

Item No.	Description	Rev.	Part No.	Qty.	Item No.	Description	Rev.	Part No.	Qty.
1	ADJUSTABLE RELEASE HANDLE	0	UP8457	1	50	PULL PIN STIFF SPRING 17/32 X 1 1/2 K-105SS		BNH0519	1
2	ADJUSTABLE TUBE	0	UP8506	1	51	RELEASE LEVER PROTECTIVE COVER		BNH1940	1
3	DOUBLE PULLEY PLATE	0	UP8507	2	52	RUBBER DONUT 3/4 X 2 1/2		BNH0068	4
4	FOAM ROLL 1 X 5 1/2 X 7 1/4	0	UP8508	2	53	RUBBER FOOT PLATE 12 X 6 COVER TFI		BNH4328	2
5	FOOT PLATE	0	UP8509	2	54	SHROUD LID RUBBER MAT LG		BNH3394	1
6	FRONT UPRIGHT	0	UP8510	1	55	SHROUD LID RUBBER MAT SMALL		BNH3395	1
7	GUIDE ROD 3/4 RD X 76 1/4	0	UP8511	2	56	SNAP LINK Z/P 8MM X 80MM		BNH0065	4
8	LAT BAR HOLDER	0	UP8512	1	57	SPLIT HEX TAP BOLT GR-8 Z/P 1/2-13 X 1 1/4		BNH2184	1
9	LAT CABLE	0	UP8513	1	58	SPLIT HEX TAP BOLT GR-8 Z/P 1/2 -13 X 3 1/2 (RND CUT)		BNH2977	1
10	LOW ROW BAR HOLDER	0	UP8514	1	59	SPLIT LOCK WASHER Z/P 3/8"		BNH2520	4
11	LOW ROW CABLE	0	UP8515	1	60	SPLIT LOCK WASHER Z/P 1/2"		BNH0572	4
12	MAIN FRAME	0	UP8516	1	61	SUPER LUBE TEFLON LUBRICANT 82340		BNH0704	2
13	SEAT PAD	0	UP8517	1	62	UHMW STOPPER		BNH3397	2
14	SELECTOR PIN W/COIL 3/8 X4 GOLD KNOB	0	UP3035	1	63	U-STYLE TAPPED HOLE NUT M6		BNH3351	1
15	STABILIZER	0	UP8505	2	64	YELLOW GRIP .485 DI X 4.75 DBL DIP. PUNCHED		BNH1514	2
16	WEIGHT SHIELD FRONT 75 3/8"	0	UP8518	1	65	FLAT WASHER SAE Z/P 1/2"		BNH2031	2
17	WEIGHT SHIELD REAR 75 3/8"	0	UP8519	1	66	HEX HEAD CAP SCREW GR-5 Z/P 1/2-13 X 1 1/4		BNH2167	2
18	WEIGHT STACK FRAME	0	UP8520	1	67	FLAT WASHER 3/8 ID X 1 1/2 OD X 3/16 THICK		BNH1717	2
19	HEX HEAD CAP SCREW GR-5 Z/P 3/8-16 X 3/4		BNH2036	1	68	10 LB STEEL WEIGHT PLATE BLACK 4 X 10		BNH4345	19
20	7/8 RD X 2 15/32 LINK 3/16 CABLE		BNH4331	2	69	10 LB TOP PLATE W/ADJ SLTR BAR 19 BLK WTS ASM		BNH1982	1
21	ALUMINUM CAP WASHER 1 1/2		BNH3080	2	70	COIL CHAIN Z/P 3/16 X 8		BNH1214	2
22	ALUMINUM FOOT ROLL CAP 1" ID		BNH3079	4	71	FACILITY SIGN BE ALERT! THE FITNESS EQUIPMENT		BNH3138	1
23	ALUMINUM INSERT CAP 2 RD WITH O-RINGS		BNH2695	2	72	LABEL- CAUTION ADJUST LEVELER		BNH2967	1
24	ALUMINUM INSERT CAP ELLIPTICAL 100MM X 50MM		BNH2398	2	73	LABEL-CG-9500 SERIES PANTONE ON CHROME BASE 1.375 X 12.75		BNH3172	1
25	BLACK NYLON BUMPER		BNH3308	1	74	LABEL-DANGER USE THIS EQUIP. ONLY (COMM. LINE) 1.5 X 2.375		BNH3088	1
26	BLACK NYLON PULLEY 3/8 X 1 X 3 1/2 (P-35375-H)		BNH0553	7	75	LABEL-EXERCISE CHART		BNH3191	1
27	CABLE STOPPER SHELL SØ1.5 X 1.75		BNH4230	2	76	LABEL-IMPORTANT ADJUST CABLE TENSION HERE		BNH2924	1
28	EDGE PROTECTOR CHROME 11 GA		BNH1724	1	77	LABEL-IMPORTANT FOR SMOOTH PERFORMANCE...		BNH2925	1
29	ELLIPTICAL RUBBER SHOE		BNH3323	5	78	LABEL-INSPECTIONS RECOMMENDED INSPECTION...		BNH3137	1
30	FINISHED HEX NUT Z/P 1/2-13		BNH0206	1	79	LABEL-NUMBERS 10-200 LBS/KGS 7/8 X 3 YELLOW & BLACK		BNH4069	1
31	FLAT HEAD SOCKET CAP SCREW Z/P 3/8-16 X 1		BNH2764	2	80	LABEL-TFI SERIAL NO. 2.5 X 1.5		BNH3147	2
32	FLAT HEAD SOCKET CAP SCREW Z/P M6-1.0 X 50		BNH3705	1	81	LABEL-WARNING ANCHOR BOLT, 2 X 1 1/4"		BNH3089	5
33	FLAT WASHER SAE Z/P 3/8"		BNH2030	46	82	LABEL-WARNING KEEP BODY, HANDS...		BNH2926	1
34	RUBBER GRIP (LOW ROW BAR HOLDER)		BNH3387	1	83	LABEL-WARNING_SERIOUS INJURY OR DEATH		BNH3134	1
35	HEX HEAD CAP SCREW GR-5 Z/P 3/8-16 X 1		BNH2037	2	84	LABEL-COMMERCIAL WARRANTY		BNH3181	1
36	HEX HEAD CAP SCREW GR-5 Z/P 3/8-16 X 1 1/4		BNH2038	2	85	LABEL-TFI 4 HIGH X 4.23 WIDE BLUE AND CHROME		BNH3699	1
37	HEX HEAD CAP SCREW GR-5 Z/P 3/8-16 X 1 3/4		BNH2040	8	86	LABEL DANGER DO NOT REMOVE... 7/8 X 1-1/2		BNH2906	1
38	HEX HEAD CAP SCREW GR-5 Z/P 3/8-16 X 2 1/2		BNH2044	5	87	LABEL-DANGER DO NOT LEAN AGAINST, 1.75X2.375		BNH3145	2
39	HEX HEAD CAP SCREW GR-5 Z/P 3/8-16 X 3		BNH2046	8	88	LABEL-WARNING DO NOT USE FOR CHINNING...		BNH2923	1
40	HEX HEAD CAP SCREW GR-5 Z/P 3/8-16 X 5		BNH2051	2	89	LABEL-WARNING KEEP BODY, HANDS, 1 1/2 X 2 1/4		BNH2908	1
41	LAT BAR 1 1/4 ALUMINUM		BNH1770	1	90	LABEL-CAUTION CHECK PULL-PIN IS FULLY... 1 1/2 X 1 3/8		BNH2912	1
42	LEVELER		BNH3662	1	91	LABEL-SCHEDULE REPLACEMENT PARTS...		BNH3135	1
43	LOW ROW BAR 1 1/4 ALUMINUM		BNH1771	1	92	LABEL-IMPORTANT FOR SMOOTH PERFORMANCE...		BNH2916	1
44	NYLON INSERT LOCK NUT Z/P 3/8-16		BNH2028	2	93	BUTTON HEAD PHILLIPS SCREW M6 X 8		BNH2650	2
45	NYLON INSERT THIN PATTERN LOCK NUT Z/P 3/8-16		BNH2026	21	94	HEX KEY ALLOY 4 MM		BNH3708	1
46	NYLON PULLEY 3/8 X 1 X 4 1/2 BLACK		BNH0506	3	95	LABEL-IMPORTANT CHECK CABLES		BNH3113	1
47	OVAL HEAD SCREW Z/P #10-24 X 1 1/8		BNH4329	2	96	HEX HEAD CAP SCREW GR-5 Z/P 1/4-20 X 1 3/4		BNH3691	1
48	OVAL TUBE PLASTIC GLIDE INSERT		BNH3345	1	97	NYLON-INSERT JAM LOCK NUT GR-5 Z/P 1/4-20		BNH3306	1
49	PLASTIC SHROUD LID		BNH3393	1	98	HEX KEY ALLOY 7/32"		BNH0575	1

PRE ASSEMBLED COMPONENTS

Item No.	Description	Rev.	Part No.	Qty.	Item No.	Description	Rev.	Part No.	Qty.
*3	DOUBLE PULLEY PLATE	0	UP8507X1	2	*15	STABILIZER	0	UP8505X1	2
*5	FOOT PLATE	0	UP8509X1	1	*16	WEIGHT SHIELD FRONT 75 3/8"	0	UP8518X1	1
*6	FRONT UPRIGHT	0	UP8510X1	1	*18	WEIGHT STACK FRAME	0	UP8520X1	1
*8	LAT BAR HOLDER	0	UP8512X1	1	*49	PLASTIC SHROUD LID		BNH3393X1	1
*12	MAIN FRAME	0	UP8516X1	1	*100	FOOT PLATE	0	UP8509X2	1

Pre-Assembled Components

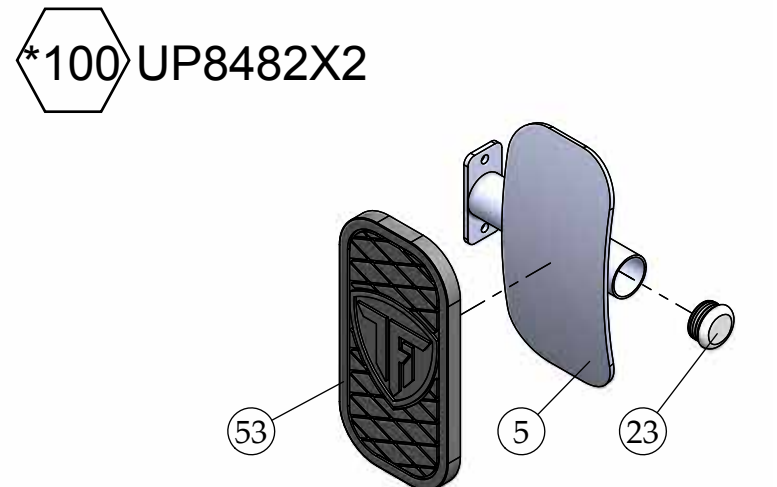
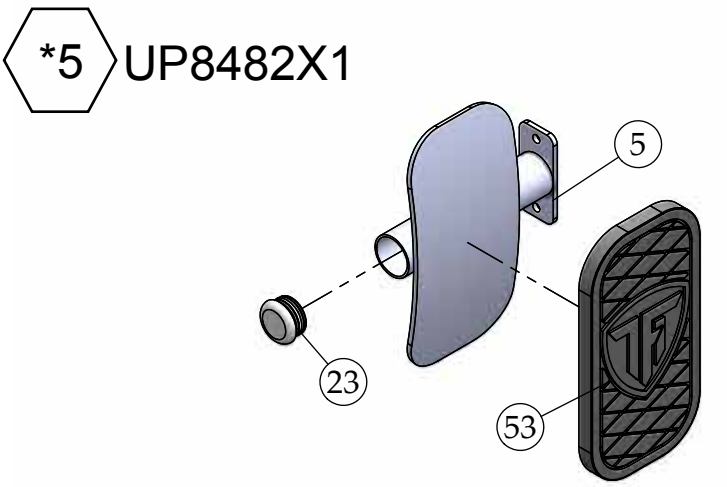
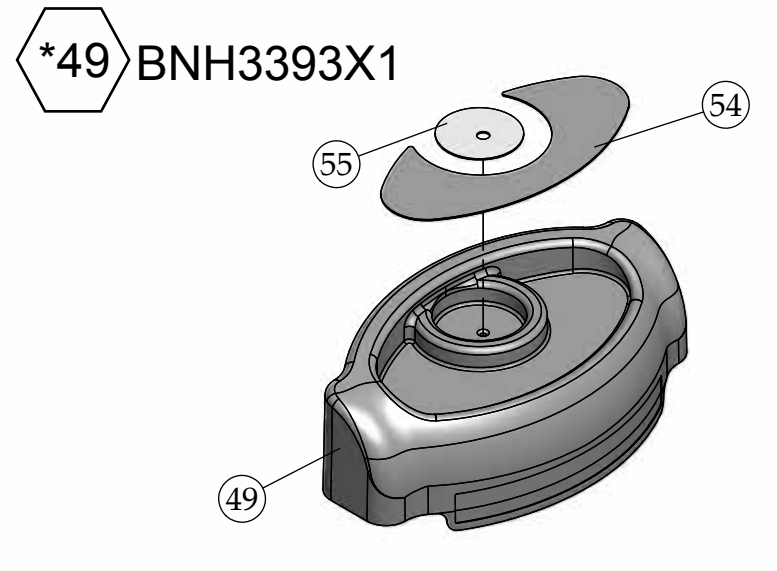
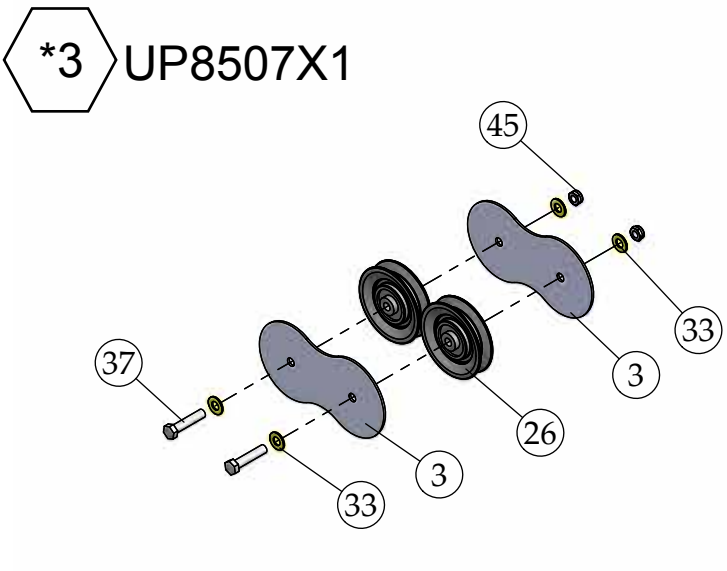
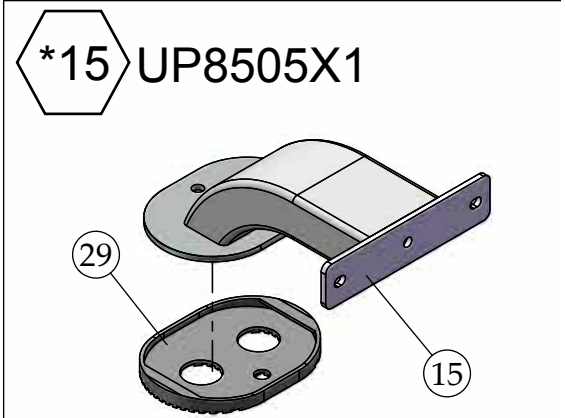
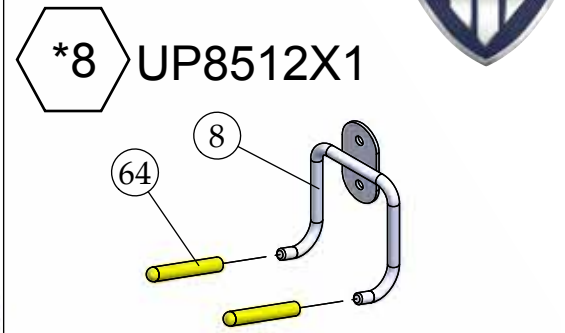
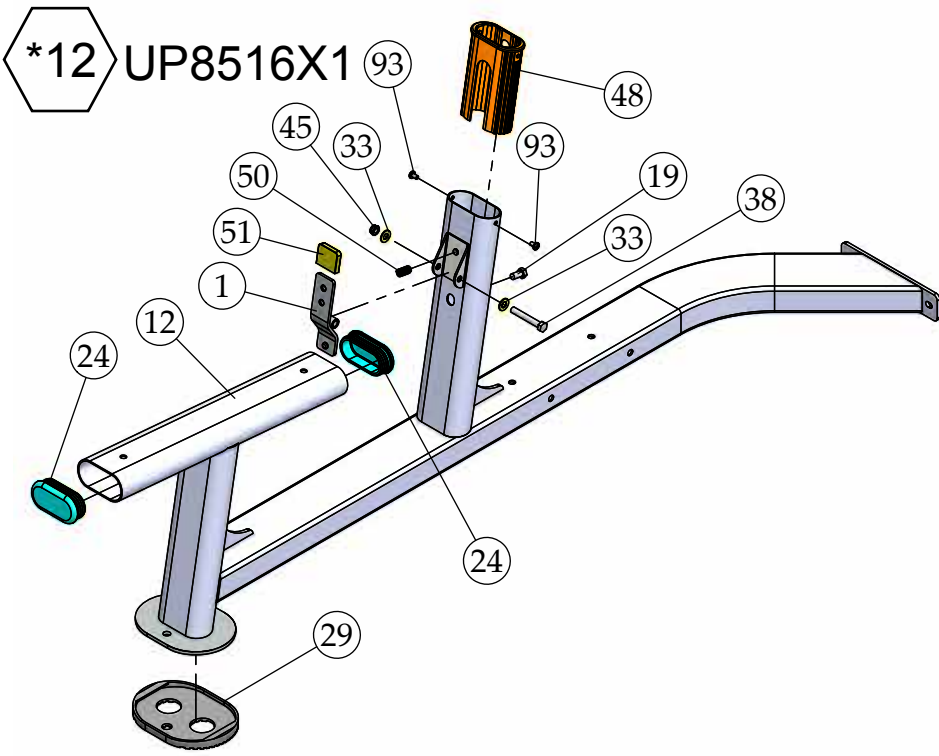

Pre-Assembled Components



*6 UP8510X1

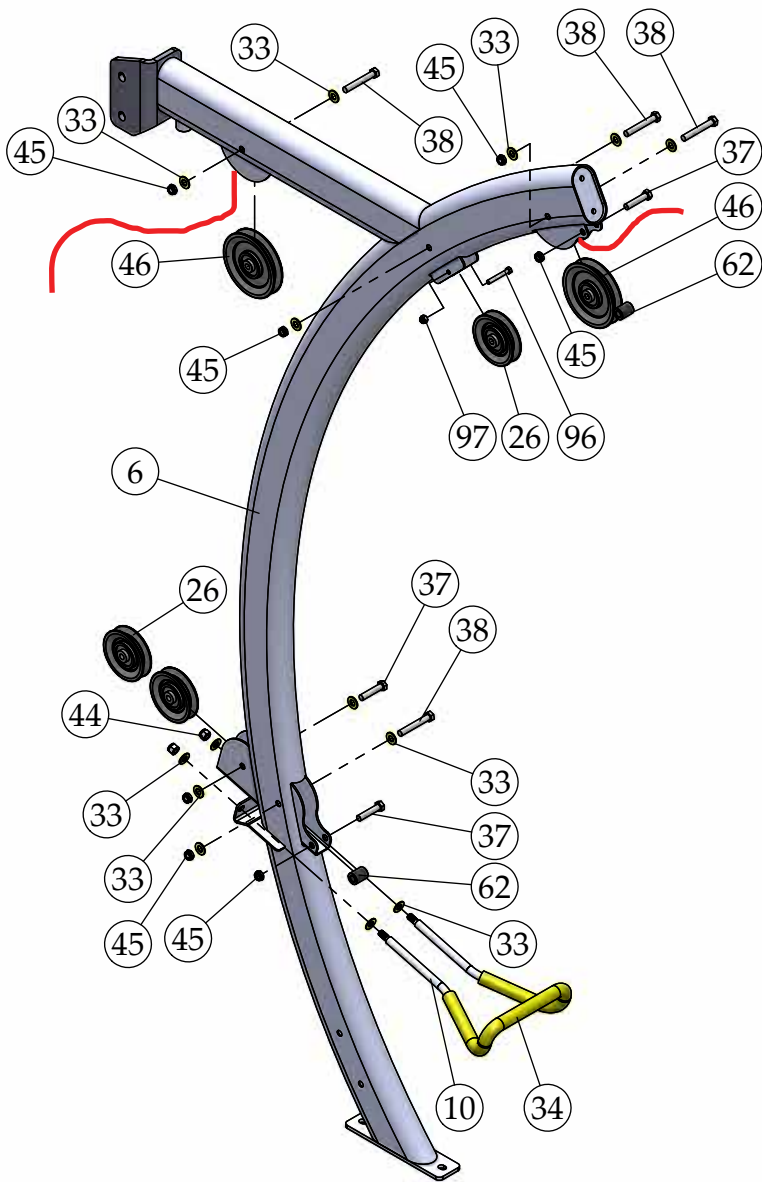

*18 UP8520X1

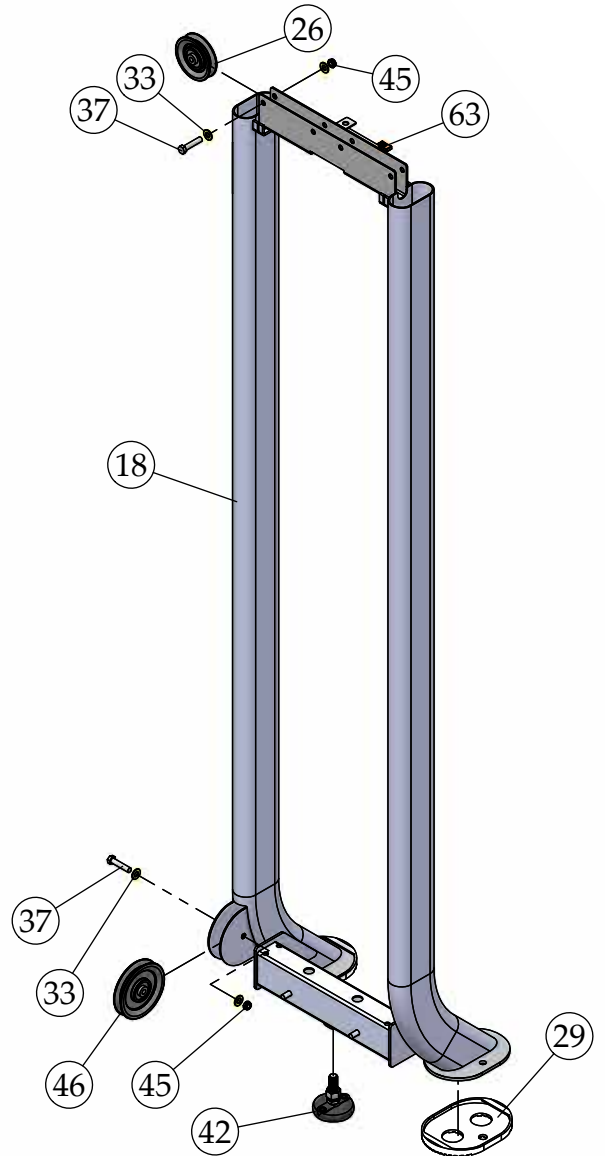

*16 UP8518X1

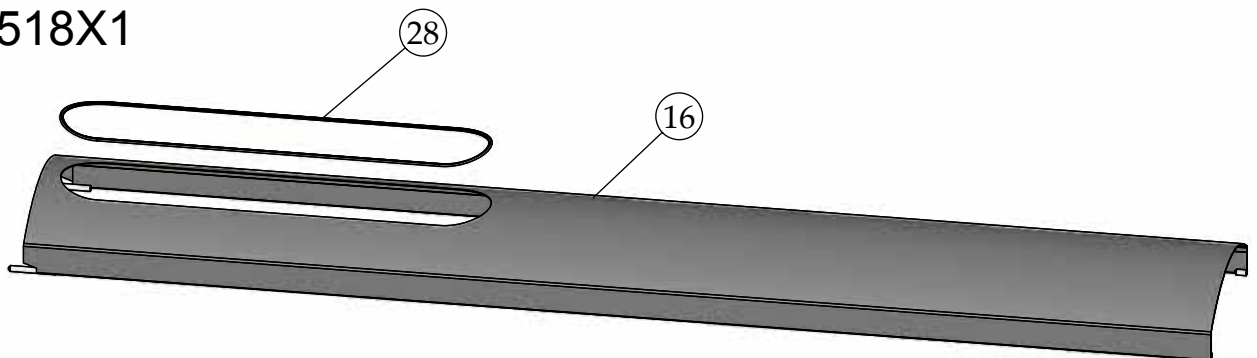



COMMERCIAL WARRANTY*

This warranty applies only in the United States to the products manufactured or distributed by TuffStuff Fitness International Inc. (TFI) under the CALGYM brand name. TFI warrants to the original purchaser that CALGYM equipment will be free from defects in material and workmanship. All warranty periods begin to run from the date of purchase to the original purchaser. The warranty and remedies set forth herein are conditioned upon proper storage, installation, use and maintenance and conformance with any recommendations of TFI. This warranty does not cover products not manufactured by TFI or products which are altered without the express written consent of TFI.

COMMERCIAL WARRANTY*:

TEN (10) YEARS: Frames, welds, cams and weight plates.

FIVE (5) YEARS: Pivot bearings, pulleys, bushings, gas shocks and guide rods.

ONE (1) YEAR: Belts, linear bearings and pull-pin components.

All other parts not mentioned, one (1) year from the date of purchase to the original purchaser.

SIX (6) MONTHS: Upholstery, cables, finish and rubber grips.

***Not recommended for membership based or dues paying facilities.**

The obligation of TFI under this warranty is limited to repairing or replacing warranted defective parts as TFI may elect, at TFI's facility in Chino, California, without charge to the purchaser. Purchaser is responsible for installation of repaired or replaced parts, and all transportation and insurance costs on returned or replaced equipment to and from TFI's facility in Chino.

THE FOREGOING SHALL CONSTITUTE THE SOLE REMEDY OF THE PURCHASER AND THE SOLE LIABILITY OF TFI WITH REGARD TO WARRANTY, WHETHER EXPRESS OR IMPLIED BY OPERATION OF LAW OR OTHERWISE, INCLUDING BUT NOT LIMITED TO ANY IMPLIED WARRANTIES OF MERCHANTABILITY OR FITNESS. TFI SHALL IN NO EVENT BE LIABLE FOR INCIDENTAL OR CONSEQUENTIAL LOSSES, DAMAGES, OR EXPENSES IN CONNECTIONS WITH EXERCISE PRODUCTS. TFI'S LIABILITY HEREUNDER IS EXPRESSLY LIMITED TO THE REPAIRS OR REPLACEMENTS OF WARRANTED DEFECTIVE PARTS.

This written warranty is the final, complete and exclusive agreement of the parties with respect to the quality or performance of the equipment and no action for breach of this written warranty or any implied warranty shall be commenced more than one (1) year after the accrual of the cause of action. No modification of this warranty or waiver of its terms shall be binding on either party unless approved in writing by an authorized representative of the party. Contact TuffStuff Fitness International, Inc. at 13971 Norton Avenue, Chino, CA 91710, before returning any defective equipment.

This warranty gives you specific legal rights and you may also have other rights, which may vary from state to state.

SERIAL #

Write your Serial number here for future reference

_____ Purchase Date



TuffStuff Fitness International, Inc.

13971 Norton Avenue, Chino, CA 91710, USA. Ph 909-629-1600 Fx 909-629-4967
www.tuffstufffitness.com service@tuffstuff.net or service1@tuffstuff.net