

TUFFSTUFF FITNESS INTERNATIONAL





*Let the Functional Training Revolution Begin!*

## **The TuffStuff CT Fitness Training System ignites a revolution in functional training!**

Made in the USA from materials only seen in the highest quality commercial strength equipment, the CT Fitness Training System offers modular options, design elements and customization for people of all ages and fitness levels.

The creative modular design gives personal trainers, studio owners and full service fitness facilities the ability to build custom exercise stations that best suit their individual and group fitness needs. With the CT Fitness Training System fitness professionals can develop an avalanche of training protocols for large groups, boot camps, individual programs and cross conditioning circuits that emphasize every aspect of functional strength, flexibility and endurance.

The CT is the perfect training system for clubs and studios looking to save cost and floor space, while maximizing their training options for revolutionary gains in revenue and profitability.







**PLEASE NOTE:** CT8 Fitness Training System as shown is a custom configuration and color. Accessories not included.



# CT Fitness Training System (CT-8100E as shown)

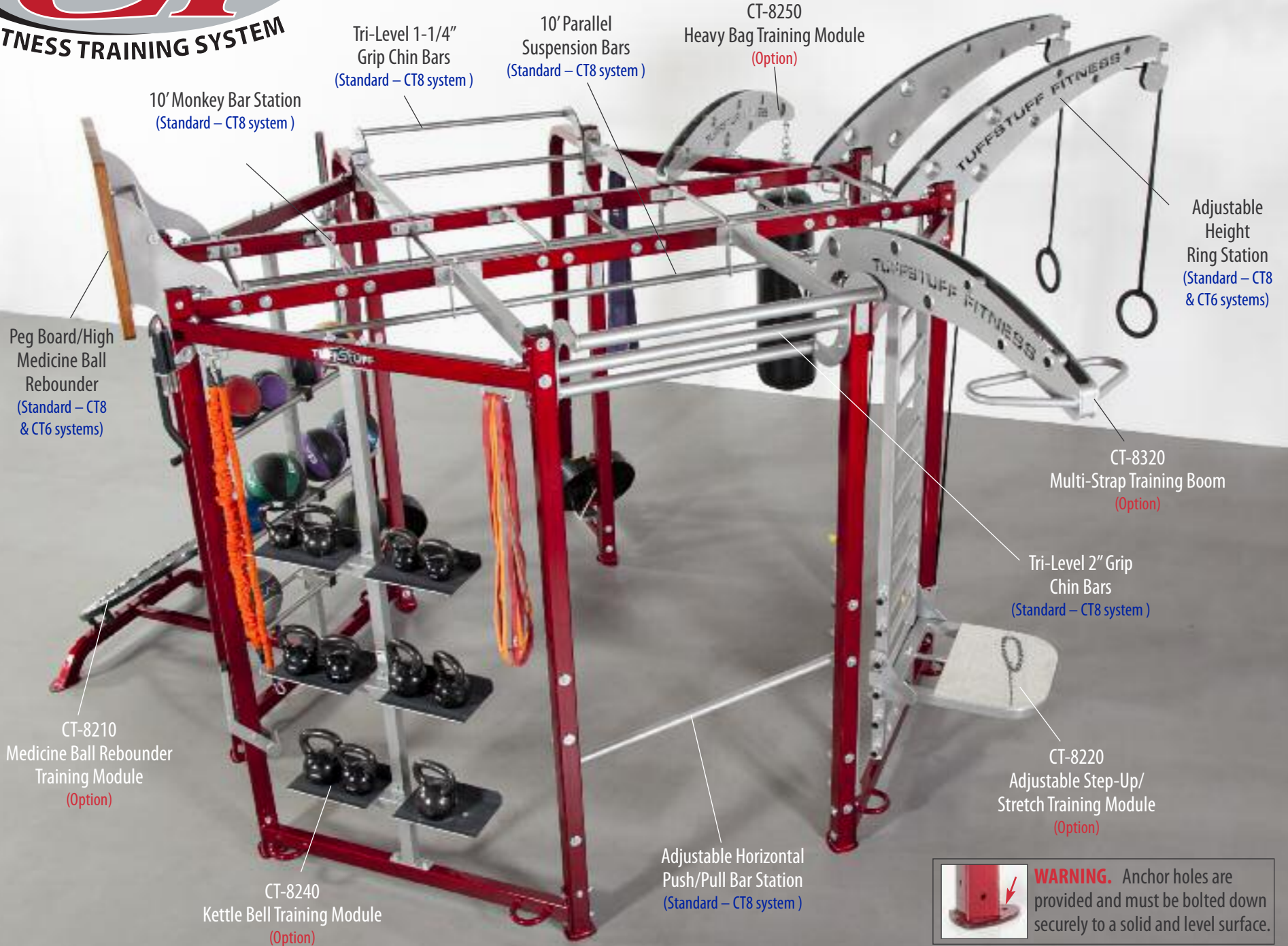

**WARNING.** Anchor holes are provided and must be bolted down securely to a solid and level surface.



## Training Modules

## Optional Stations & Accessories



**CT-8210**  
Medicine Ball Rebounder  
Training Module



**CT-8220**  
Adjustable Step-Up/Stretch  
Training Module



Step Deck Storage Rack  
included with CT-8220  
Training Module



**CT-8310**  
Squat/Press  
Racking Station



**CT-8230**  
Battle Rope Training Module



**CT-8240**  
Kettle Bell Training Module



**CT-8250**  
Heavy Bag Training Module



**CT-8320** Multi-Strap Training Boom



**CT-8330\***  
Olympic Bar  
Landmine



**CT-8340\***  
Dip Handle

\* CT-8330 & CT-8340 cannot occupy same position.



# CT-8100E Elite Fitness Trainer



Shown with CT-8210 & CT-8220 Training Modules.  
Accessories not included.

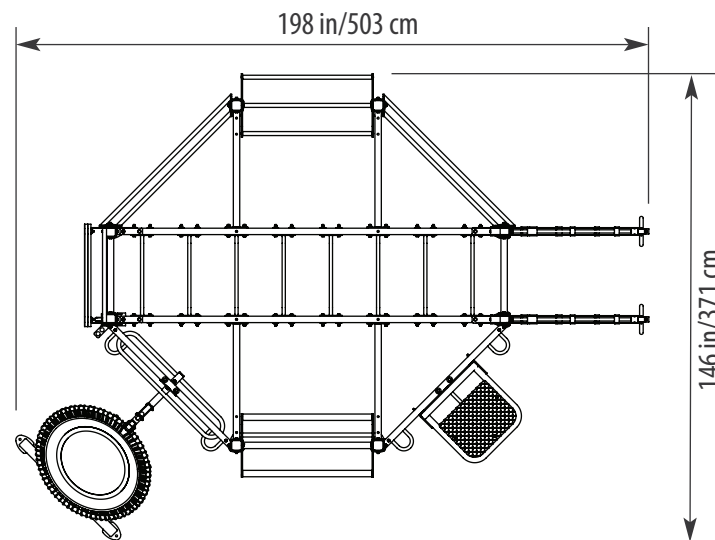

Height: 117 in/297 cm    Weight: 950 lb/431 kg

### Standard Features:

- Peg Board/High Medicine Ball Rebounder
- 10' Parallel Suspension Bars
- Adjustable Horizontal Push/Pull Bar Station
- (2) Dual Bar Training Modules
- 10' Monkey Bar Station
- Tri-Level 1-1/4" & 2" Grip Chin Bars
- Adjustable Height Ring Station
- Two (2) Training Modules (additional cost)

**Customization with your choice of training modules, options and accessories is available for additional costs. Please inquire with your sales representative.**

## Most popular CT-8100E configurations:



Shown with CT-8210, CT-8220 and CT-8230 training modules



Shown with CT-8210, CT-8220, CT-8230 and CT-8250 training modules



Shown with CT-8210, CT-8220 and CT-8240 training modules





# CT-8000B Base Fitness Trainer



Shown with CT-8210 & CT-8220 Training Modules.  
Accessories not included.

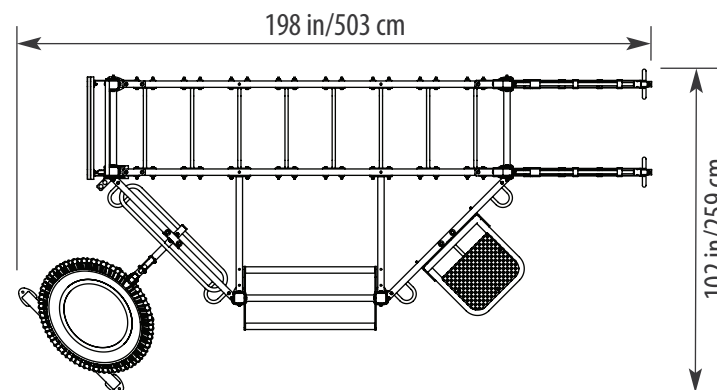

Height: 117 in/297 cm Weight: 760 lb/345 kg

### Standard Features:

- Peg Board/High Medicine Ball Rebounder
- 10' Parallel Suspension Bars
- Adjustable Horizontal Push/Pull Bar Station
- Two (2) Training Modules (additional cost)
- 10' Monkey Bar Station
- Tri-Level 1-1/4" or 2" Grip Chin Bars
- Adjustable Height Ring Station

**Customization with your choice of training modules, options and accessories is available for additional costs. Please inquire with your sales representative.**

## Most popular CT-8000B configurations:



Shown with CT-8210, CT-8220 training modules and CT-8310 Squat/Press Racking System



Shown with CT-8220 and CT-8230 training modules



Shown with CT-8210 and CT-8250 training modules

# CT-6000 Fitness Trainer

**Standard unit configuration.**

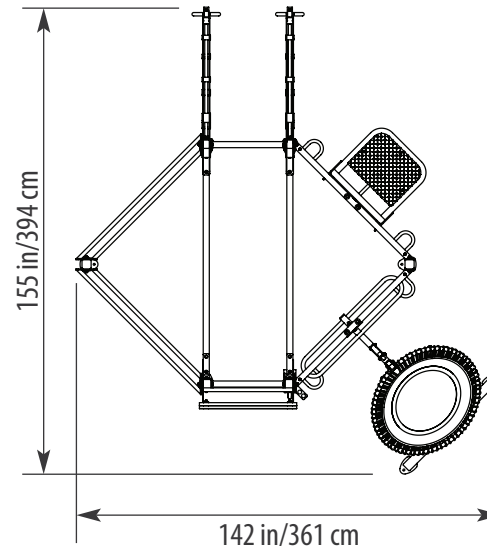

Height: 117 in/297 cm

Dimensions vary with each custom configuration and training modules, options or accessories.

**Standard Features:**

- (2) Dual Bar Training Modules
- Peg Board/High Medicine Ball Rebounder
- Adjustable Height Ring Station
- Two (2) Training Modules (additional cost)

**Customization available:**

Dual Bar Training Modules can be replaced by any training modules of your choice for additional costs.

**Can be combined with CT-4000 unit in Daisy-chain fashion (refer to pg 10 for details).**

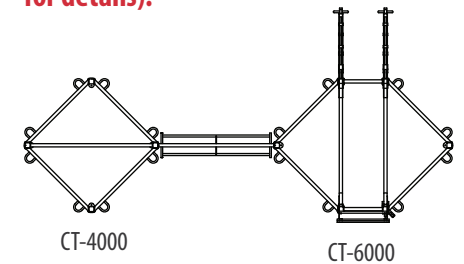

Shown with CT-8210 & CT-8220 Training Modules.

## Most popular CT-6000 configurations:



Shown with CT-8210, CT-8220, CT-8240 and Dual Bar training modules



Shown with CT-8210, CT-8220, CT-8230, CT-8250 training modules and CT-8340 Dip handle



Shown with CT-8210, CT-8220, CT-8250 and Dual Bar training modules



# CT-4000 Fitness Training System



Shown with CT-8210 and CT-8220 Training Modules.

**Standard unit configuration.**

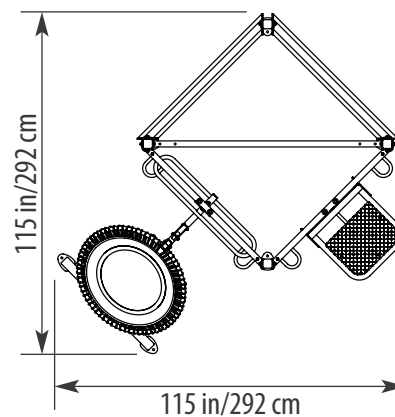

Height: 96 in/244 cm

Dimensions vary with each custom configuration and training modules, options or accessories.

## Standard Features:

- (2) Dual Bar Training Modules
- Two (2) Training Modules (additional cost)

Customization available – Dual Bar Training Modules can be replaced by any training modules of your choice for additional costs.

Can be combined with CT-6000 unit in Daisy-chain fashion (refer to pg 10 for details).

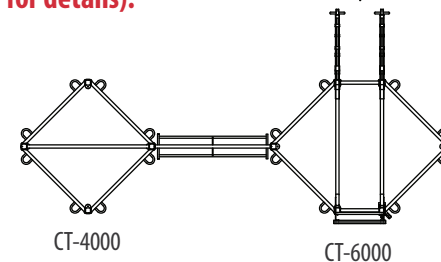

## Most popular CT-4000 configurations:



Shown with CT-8210, CT-8220, CT-8230 and and CT-8250 training modules.



Shown with CT-8210, CT-8220, CT-8240 and Dual Bar training modules.



Shown with CT-8210, CT-8220, CT-8250 and Dual Bar training modules.

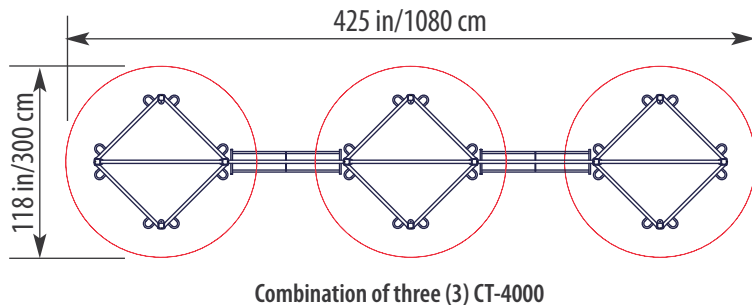
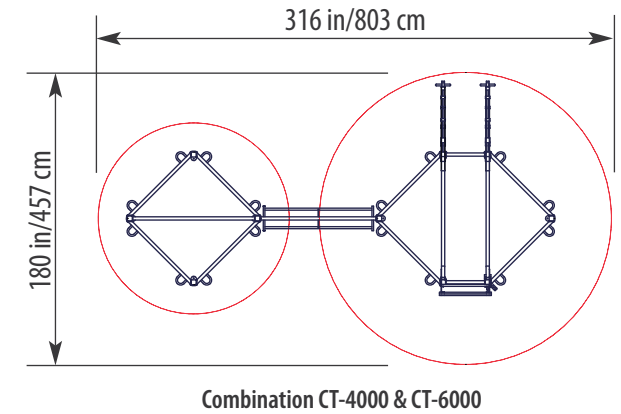
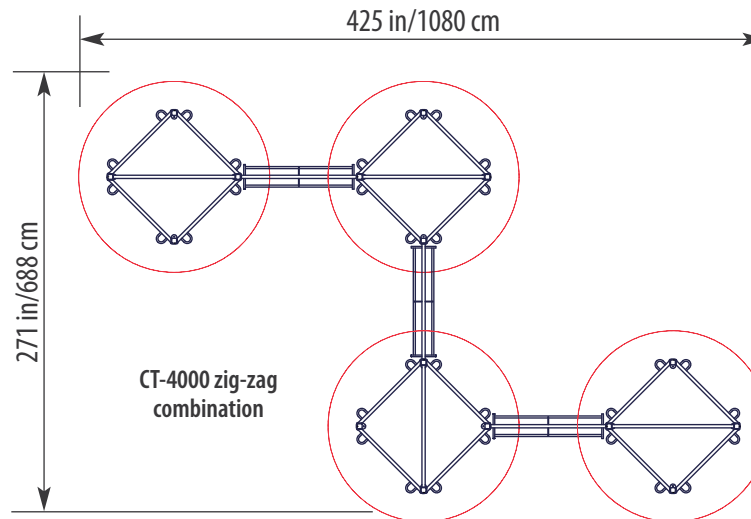
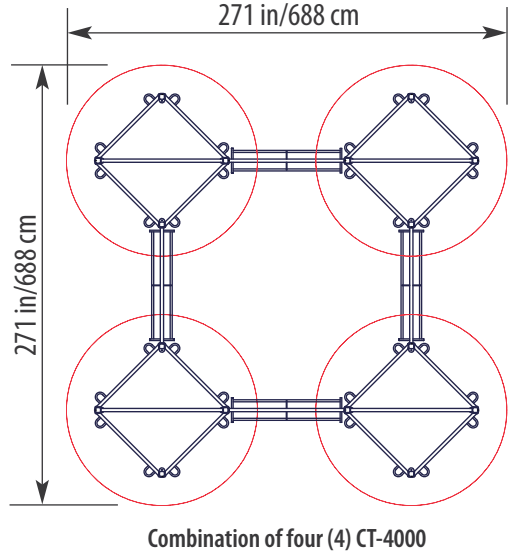
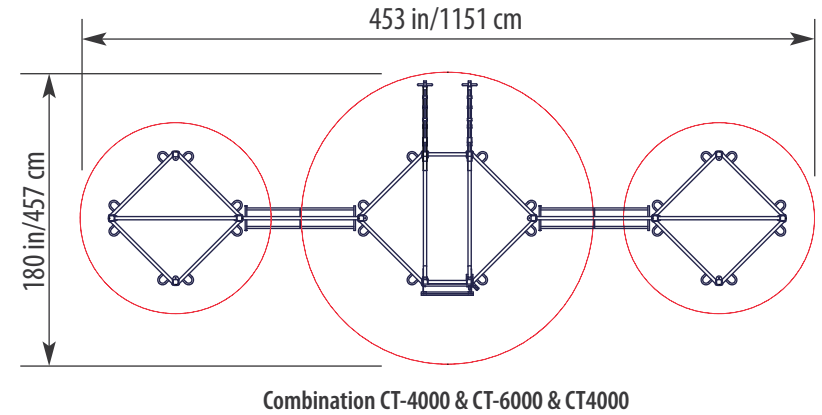
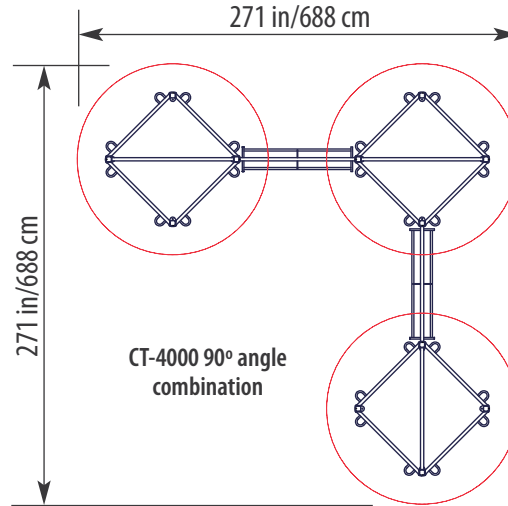
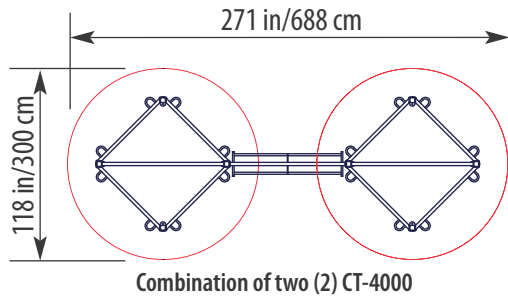

### CONNECTOR OPTIONS



CT-8350 Dual Bar Connector



CT-8360 Rock Climbing Connector

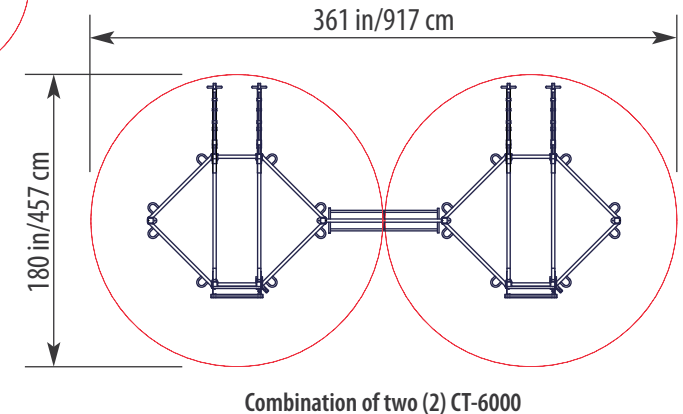





## CT Fitness Training System Design Features:



Peg Handle Holder



Peg Board Step



Olympic Bar Holder



Safety Handle



Dual Bar Modules



Bumper Plate Storage



Anchor Loops



Accessory Storage Hooks



(1) Charcoal Texture; (2) Platinum Sparkle; (3) Red Baron; (4) Sky White;  
(5) Twilight Blue; (6) Matte Black and (7) Wrinkle Black

## CUSTOMIZATION:

Call your sales representative for special custom outdoor protection of the equipment.

## Specifications

- 3"x3" and 2"x3" x .120 (11-gauge) tubular steel upright posts and top/bottom/cross supports utilized for all structural frame assembly to offer and maintain maximum structural integrity.
- 1", 1-1/4" and 2" .120 (11-gauge) HG round tubing for added structural support and various grip thickness.
- All mounting plate connectors are 3/8" (.360) thick 1018 cold rolled steel.
- Floor mount anchor plates made of 1/4" (.240) HRPO 1018 grade steel.
- TuffStuff's proprietary electrostatically applied powder coat finish and oven baked to insure durability.
- Grade 5 blue zinc frame bolts used for optimal strength and durability.
- 1/4" 3003 aluminum tread bright step platform for maximum strength and no-slip training.
- CT Fitness Training System must be bolted securely to a solid and level surface by a licensed contractor.

## Commercial Warranty

**10 YEARS:** Structural frames (coating excluded).

**1 YEAR:** Peg Board (excluding finish & logo) and Pulleys.

**6 MONTHS:** Coating, Plastic Glides, Nylon Rings & Straps and Hardware.

**Accessories not included or covered under warranty.**

Refer to the Owner's Manual/Assembly Instruction for details, assembly & maintenance requirements, review and understand all danger, warning and caution labels. For exercises and procedures, please refer to the Training Manual and DVD included.

**NOTICE:** TuffStuff continually engages in research related to product improvement. As a result, the product received by the customer may differ slightly from its published description. Improvements in materials, production techniques and design refinement may at any time be introduced into our products. TuffStuff reserves the right to make changes in its product without notice.



**TUFFSTUFF FITNESS INTERNATIONAL INC.**

13971 Norton Avenue, Chino, CA 91710, USA PH: 909-629-1600

FX: 909-629-4967 info@tuffstuff.net

[www.tuffstufffitness.com](http://www.tuffstufffitness.com)

