



OWNER'S MANUAL & TRAINING GUIDE

Thank you for purchasing the AB COASTER®.
Our customer service staff is ready to help
and to answer any questions.

Our phone number is: 908-879-2713
The Ab Coaster Company, 173 Route 206, P.O. Box 9
Chester, NJ 07930
Website: www.abcoasterclub.com
Email: info@abcoasterclub.com

Please call us if you have any questions.
Customer service staff can be reached
Monday to Friday from 9:00 AM to 5:00 PM Eastern Standard Time.
You can also send us an email, or visit our website
for additional customer service information.

Prior to calling or emailing,
please have the following information with you:

- Customer Name and Address
- Telephone Number
- Proof of Purchase
- Product Model Number

© 2010 The Ab Coaster Company. All Rights Reserved.
U.S. Pat. Nos. 7,611,445, 7,585,263, 7,485,079, and Other Patents Pending.
U.S. Trademark Registration Number 3407362.

AbC_CTL_MAN_V2_100519



• COMMERCIAL SERIES •

Maximum User
Weight is 450 lbs.



TABLE OF CONTENTS

Safety Instructions for Assembly and Usage	3
How to Use the Ab Coaster®	3
Exercise Instructions	4
Adjusting the Seat	5
Adjusting the Hand Grip	5
Resistance Training	6
Moving and Storing the Ab Coaster®	6
Parts List and View	7
Assembly Overview	8
Step-By-Step Assembly	9
Warnings	15
Warranty	15

SAFETY INSTRUCTIONS FOR ASSEMBLY AND USAGE

Safety comes first. Please read this instruction guide completely before assembling and using the Ab Coaster®. Please keep this guide in a safe place and accessible to all staff.

- Make sure all bolts and screws are tight prior to each day's use. Make sure machine is working properly every day. **WARNING:** The safety level of this equipment can be maintained only if it is examined regularly for damage and wear. Pay special attention to the moving parts, including the bearings under the carriage and the pull pin which secures the carriage, and to components which are susceptible to wear such as the rear bumpers, the arm rests and seat.
- Periodic maintenance is required on all exercise equipment in order for it to remain in good operating condition.
- Place and use the machine on a flat, level surface. Maintain at least 2 feet of free space around machine for safe operation.
- Place all warnings and safety labels as provided by manufacturer on the machine if not already applied.
- Train and educate members, clients or customers prior to using this machine.
- **IMPORTANT:** Keep all children and pets away from machine.
- **WEIGHT LIMIT:** Users must weigh no more than 450 lbs. (204 kg)

HOW TO USE THE AB COASTER® CTL

FEATURES AND TIPS: The Ab Coaster® CTL is designed to help you exercise your abdominal muscles via a leg lift motion. Unlike the popular ab crunch exercise, which works your ab muscles from the "top down", the Ab Coaster® moves in the opposite direction, working your abs from the "bottom up." The motion requires you to lift your knees and legs while contracting your abs.

The Ab Coaster® features a Seat attached to a swing arm to aid you in performing the abdominal lift motion. The starting position requires you to kneel on the Seat while resting your arms on the arm rests. The exercise requires you to lift the Seat using your abdominal muscles, not your upper body. The key to performing the exercise properly is to concentrate on contracting your ab muscles while lifting the Seat. Your upper body should be stable and not moving while you exercise.

Setting up the Ab Coaster®: Make sure the Ab Coaster® is placed on a flat, stable surface.



EXERCISE INSTRUCTIONS:

1. Approach the Ab Coaster® CTL from the rear of the unit.
2. Adjust Hand Grip and place forearms and elbows on arm pads. Grasp handles to maintain your balance.
3. While grasping handles, place knees on Seat so that your feet are hooked on the back edge of the seat. You are now ready to exercise.
4. Keeping your back straight, pull your knees forward until you fully contract your abs. DO NOT move your upper body while performing exercise. Make sure you use your abs to lift the Seat carriage, not your upper body.
5. Return slowly to starting position, and repeat.

Please visit www.AbCoasterClub.com and www.AbCoasterBlog.com to view video of proper exercise usage of the machine.



ADJUSTING THE SEAT

The Seat is free-moving so that you can turn your knees and work on your obliques. Turn knees to right to exercise left oblique; turn knees to left to exercise right oblique. Move knees side to side for free-style motion training.

ADJUSTING THE HAND GRIP

To adjust hand grip, pull up on pop-pin and move grip up or down. Then secure the grip by releasing pop-pin into the hole. Make sure hand grip is secure before using.



RESISTANCE TRAINING (Weights Not Included)

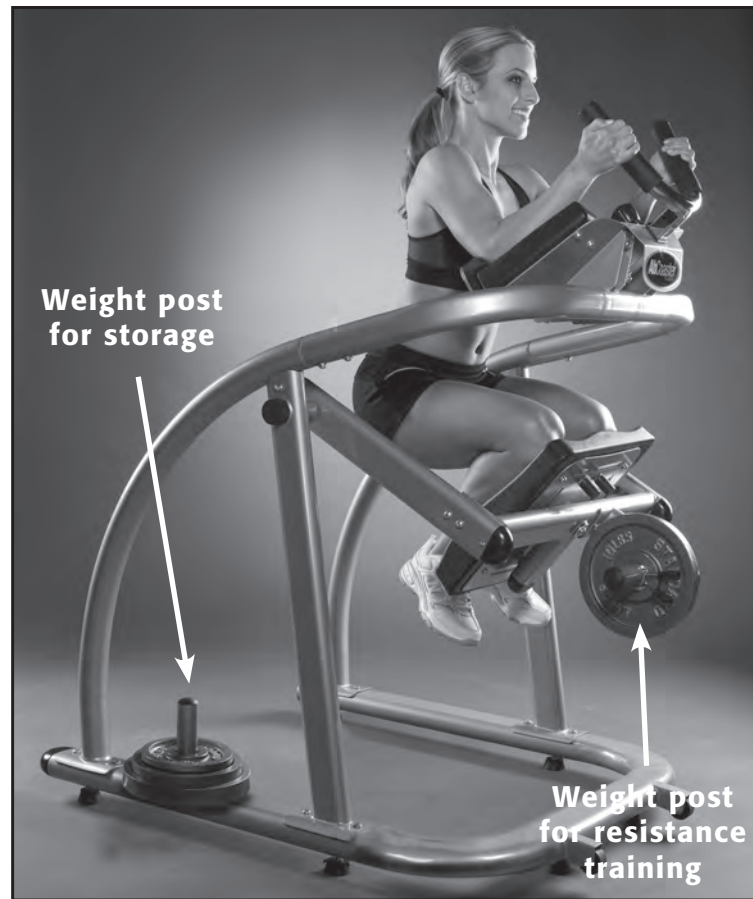

USING ADDED WEIGHT FOR RESISTANCE: There is a weight post underneath the Seat of the Ab Coaster® CTL for adding weights (not included) for extra resistance during exercise.

CAUTION:

Do not add more than 40 lbs. of weight in total to the post (4 plates of 10 lbs. each). Use safety clip when adding weights (clip not included). Before adding any weight, ensure that you are able to perform the exercise with proper form without any additional weight.

Please visit www.AbCoasterClub.com and www.AbCoasterBlog.com to view video of proper usage of the machine.

WARNING: As with any physical exercise routine, injuries may result from incorrect usage of equipment or excessive training.

MOVING AND STORING THE AB COASTER® CTL

There are 2 wheels attached to the front leg support of the Ab Coaster® in order to aid in the moving and storage of the unit.

Keep stored in a cool, dry place. If placed in long-term storage, you should cover the unit with a cloth or other material to protect the unit from excessive dust or dirt accumulation.

Maintenance:

Keep unit clean and free of debris. Wipe periodically with cloth to keep track clean.

PARTS LIST & VIEW

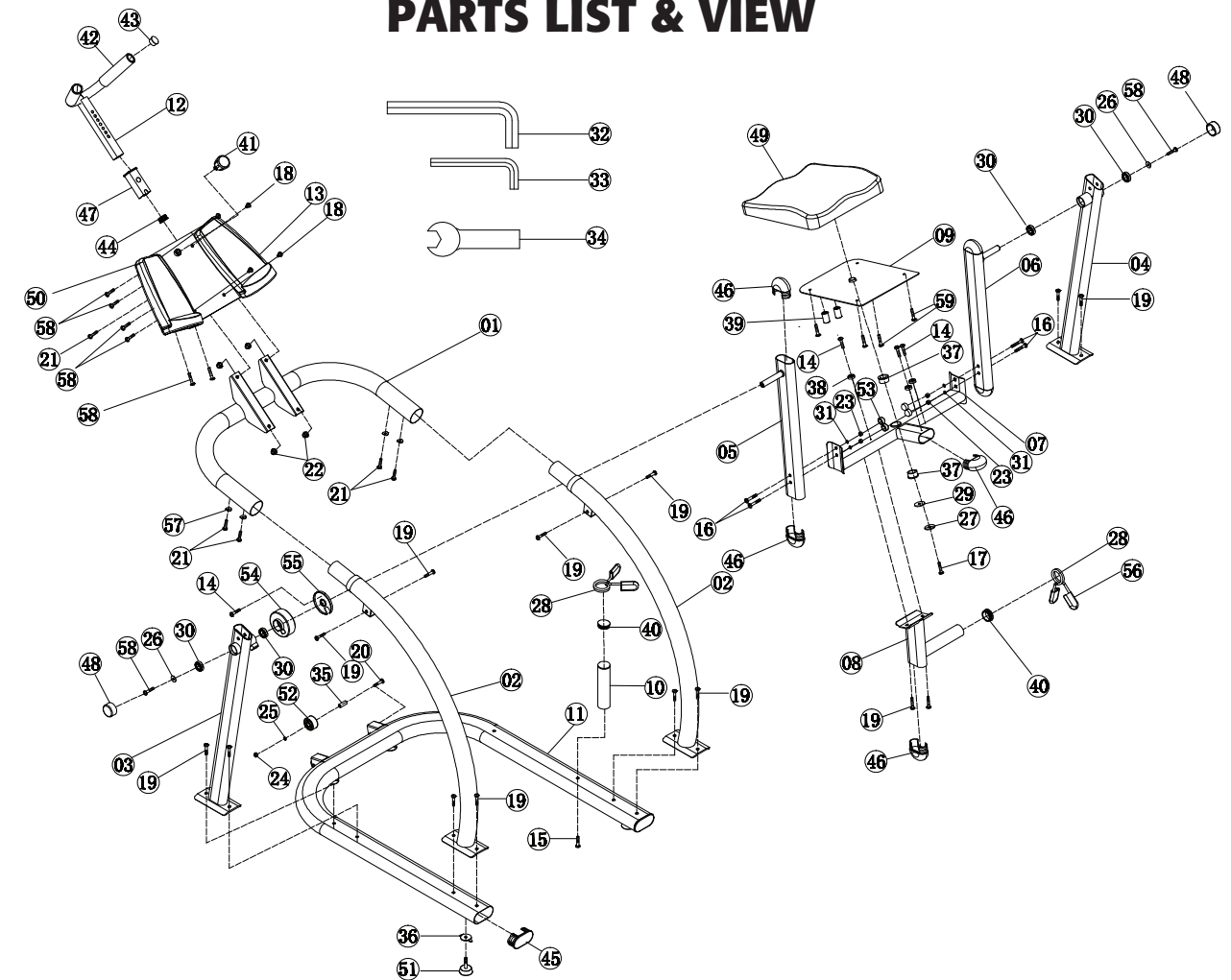

NO.	Part Name	Specification	QTY (PCS)	NO.	Part Name	Specification	QTY (PCS)	NO.	Part Name	Specification	QTY (PCS)
01	arm plate support frame		1	23	M10 nut white nylon	M10 white nylon	4	45	oval end cap	match oval100*50*2.0 tubing	2
02	side frame		2	24	M8 nut white nylon	M8 white nylon	2	46	oval tubing	match oval 80*40*2.0 tubing	6
03	left support frame		1	25	flat washer	OD16*ID8*1.5	2	47	square tubing	ø40*2.0ø32 tubing	1
04	right support frame		1	26	flat washer	OD30*ID11*2.5	2	48	round tubing	ø48*25,match ø42	2
05	left swing arm		1	27	spring washer	ø10	1	49	knee pad	410*380*80	1
06	right swing arm		1	28	clamp	match ø45*2.0 th=tubing	2	50	arm pad	L310*W150*H120	2
07	knee pad support frame		1	29		ø38*ø10.5*ø2	1	51	leveler	ø50*ø7,M10	6
08	knee pad weight post		1	30	bearing	model: 619042 OD37*ID20*T9	4	52	roller	ø47*27,34g	2
09	knee pad plate		1	31	flat washer	OD20*ID11*2.0	4	53	M10 nut cover	match M10 nut	4
10	frame weight post		1	32	S8 hex screw	S8	1	54	swing arm cover	ø100*37	1
11	base frame		1	33	S6 hex screw	S6	1	55	swing arm cover	ø92*8	1
12	adjustable U handle		1	34		S17 4mm thickness	1	56	clamp cover	25*10*44	4
13	arm plate assembly		1	35	roller bushing	ø12.5*ø8*33	2	57	arc washer	ø22*ø8.5*1.5T	4
14	phillips screw	ST4.8*15	4	36	leveler orientation	63*45*3	6	58	M10xL15 hex screw	M10*L15,full thread	14
15	M10xL70 hex screw	M10*L70, (15mm thread)	1	37	ø38 nylon bushing	OD38*ID25*H19	2	59	M8xL15 hex screw	M8*L15,full thread	4
16	M10xL55 hex screw	M10*L55, (15mm thread)	4	38	seat swivel bushing	ø25*T8	3				
17	M10xL25 hex screw	M10*L25, full thread	1	39		ø23*37	2				
18	M10xL25 hex screw	M10*L25, full thread	4	40	weight post end cap	match ø45*2.0 tubing	2				
19	M10xL15 hex screw	M10*L15, full thread	14	41	handle adjustment knob	M16*1.5P	1				
20	M8xL45 hex screw	M8*45 (15mm thread)	2	42	handlebar foam	ø38*3*150,match ø32*1.5 tubing	2				
21	M8xL15 hex screw	M8*L15, full thread	5	43	handlebar end cap	matchø32*2.0 tubing	2				
22	M10 nut	M10	4	44	square end cap	match 32*32*1.5 tubing	1				



ASSEMBLY OVERVIEW

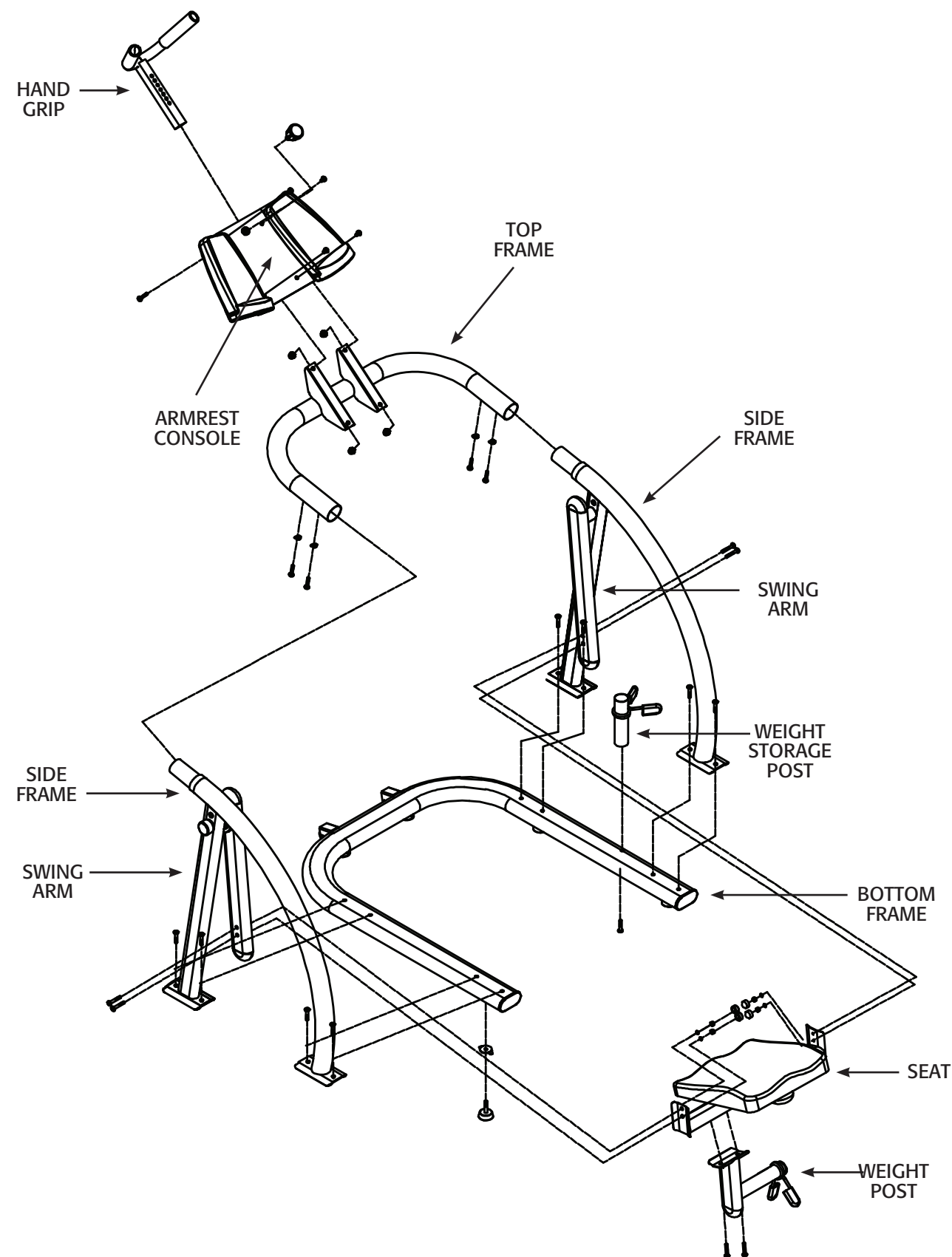

8

STEP-BY-STEP ASSEMBLY

IMPORTANT: Remove all parts from packing and inspect for damage.
Retain packing materials if possible.

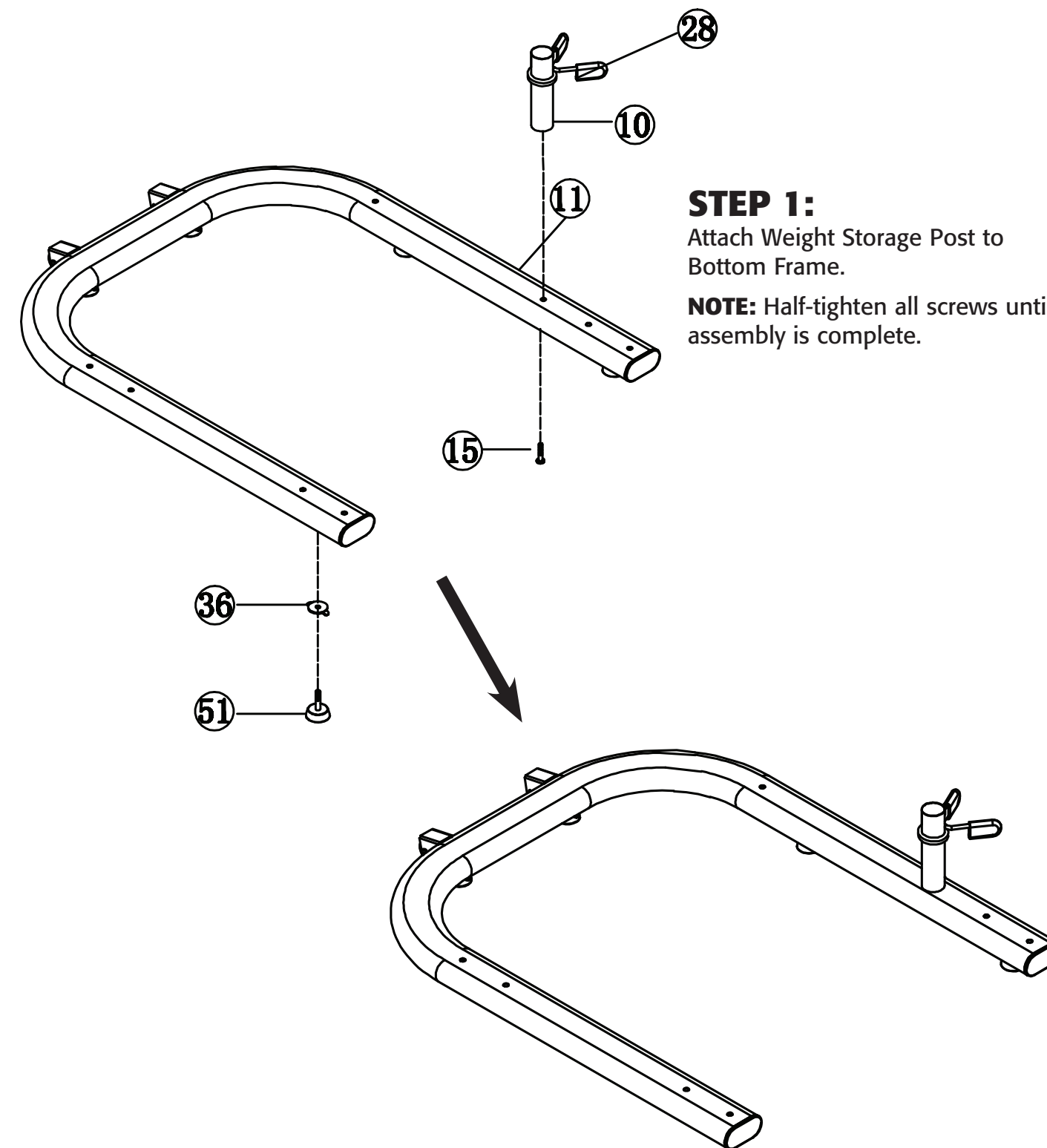

9





STEP 2:

Attach Side Frame and Swing Arm to both sides of Bottom Frame.

NOTE: Be sure to use correct size screws as indicated. Half-tighten all screws until assembly is complete.

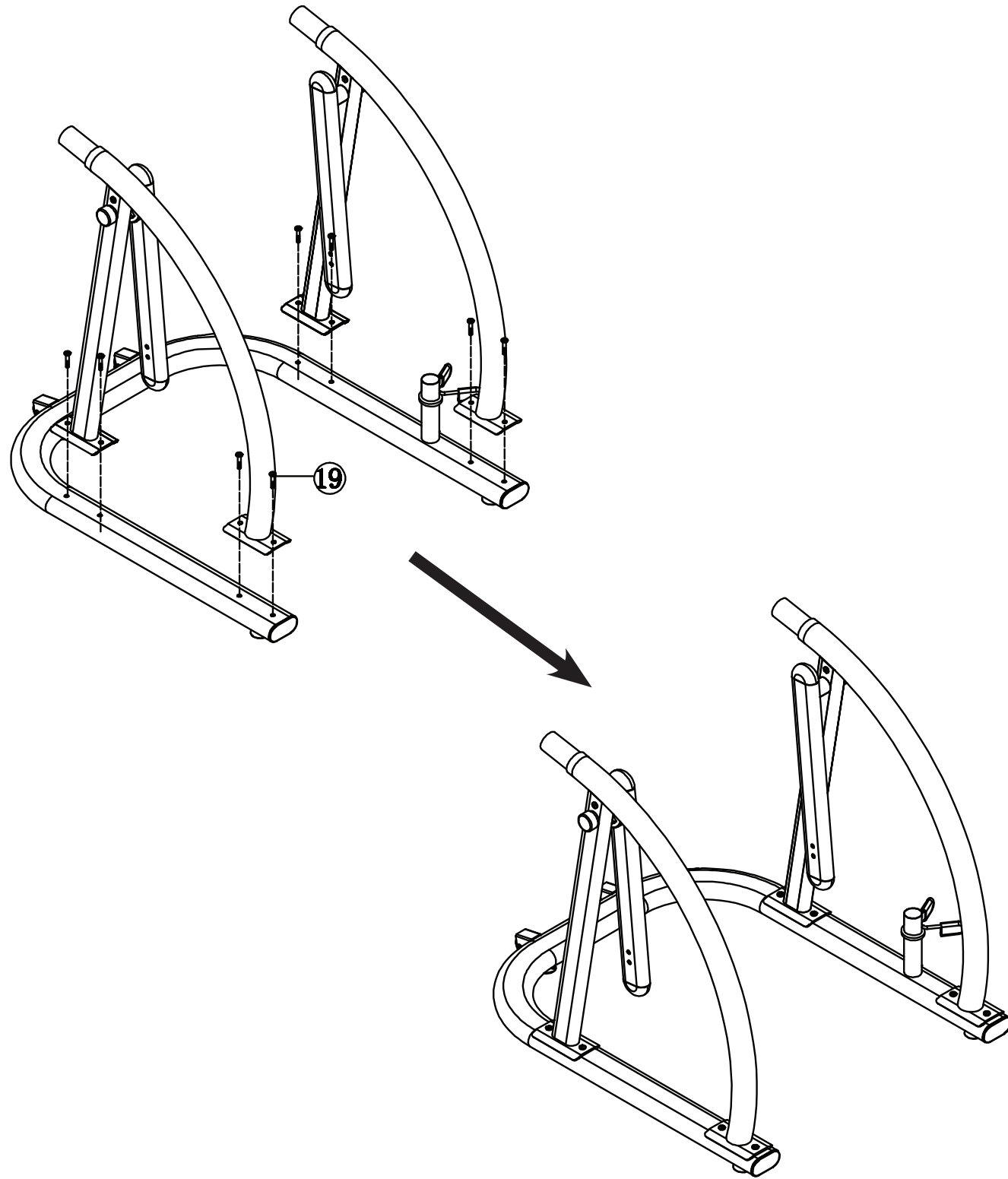

10

STEP 3:

Attach Top Frame to both Side Frames.

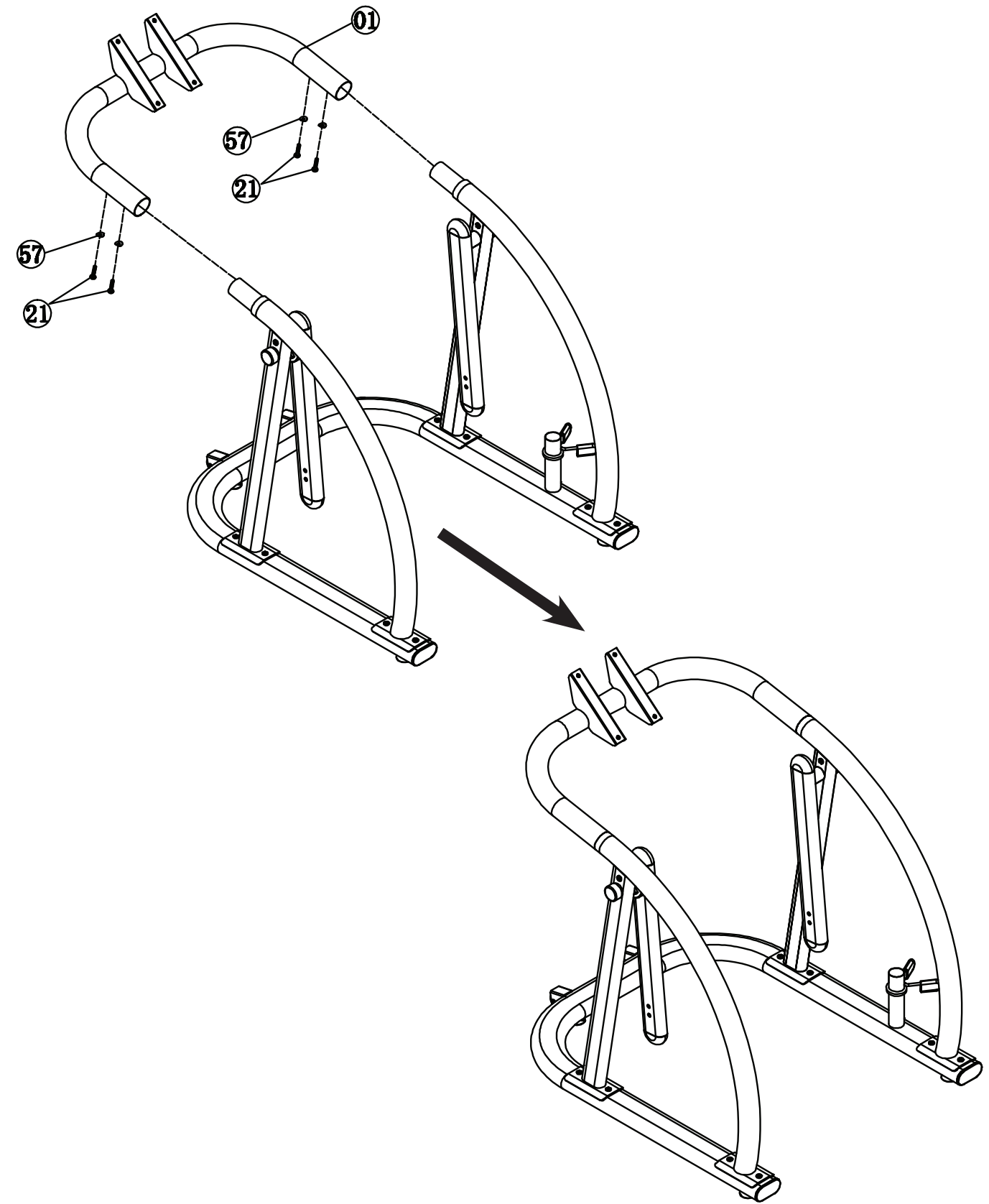

11





STEP 4:

Attach Weight Post to Seat and then attach Seat to both Swing Arms.

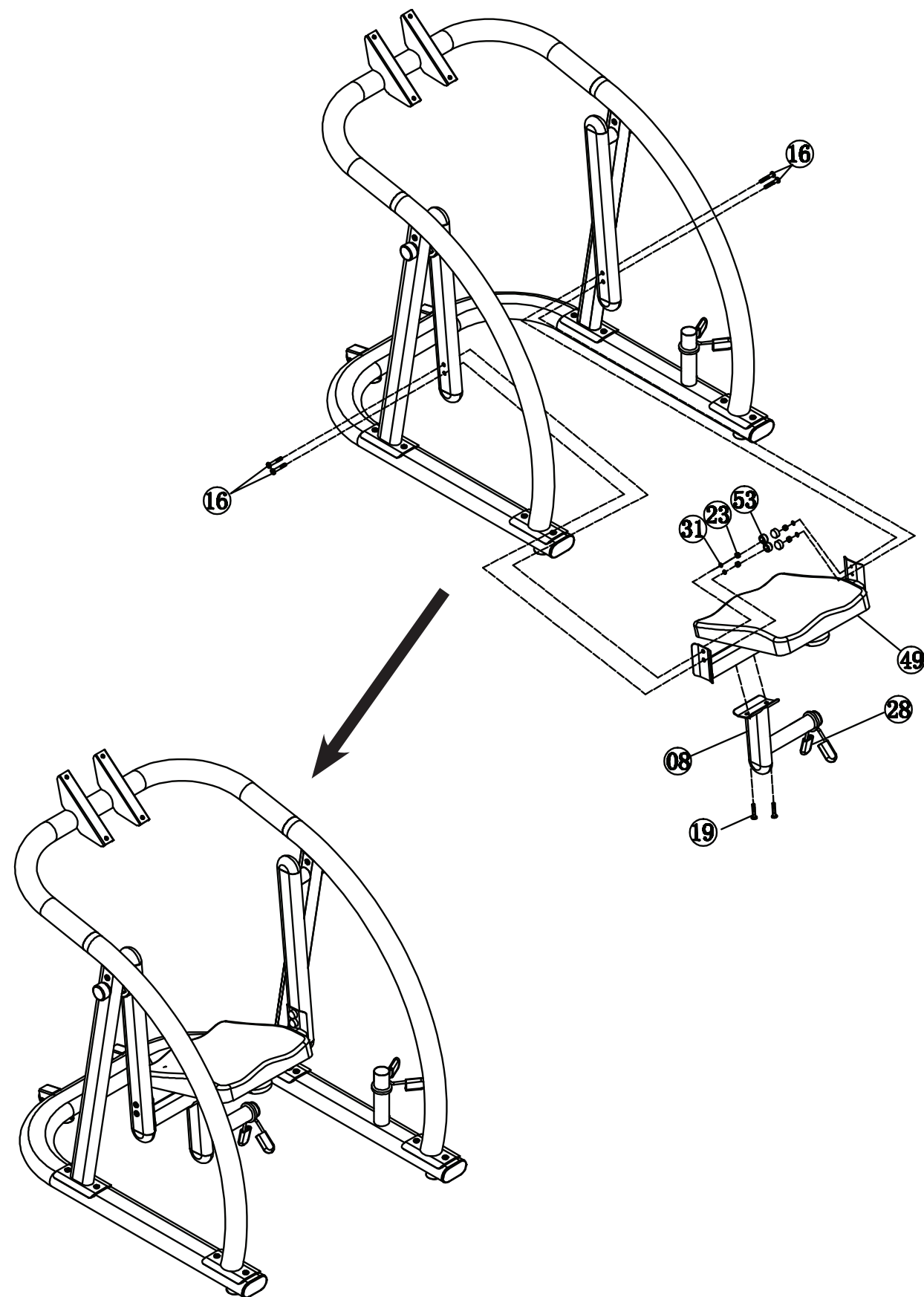

12

STEP 5:

Attach Arm Rest Console to Top Frame, and then attach Hand Grip to Arm Rest Console.

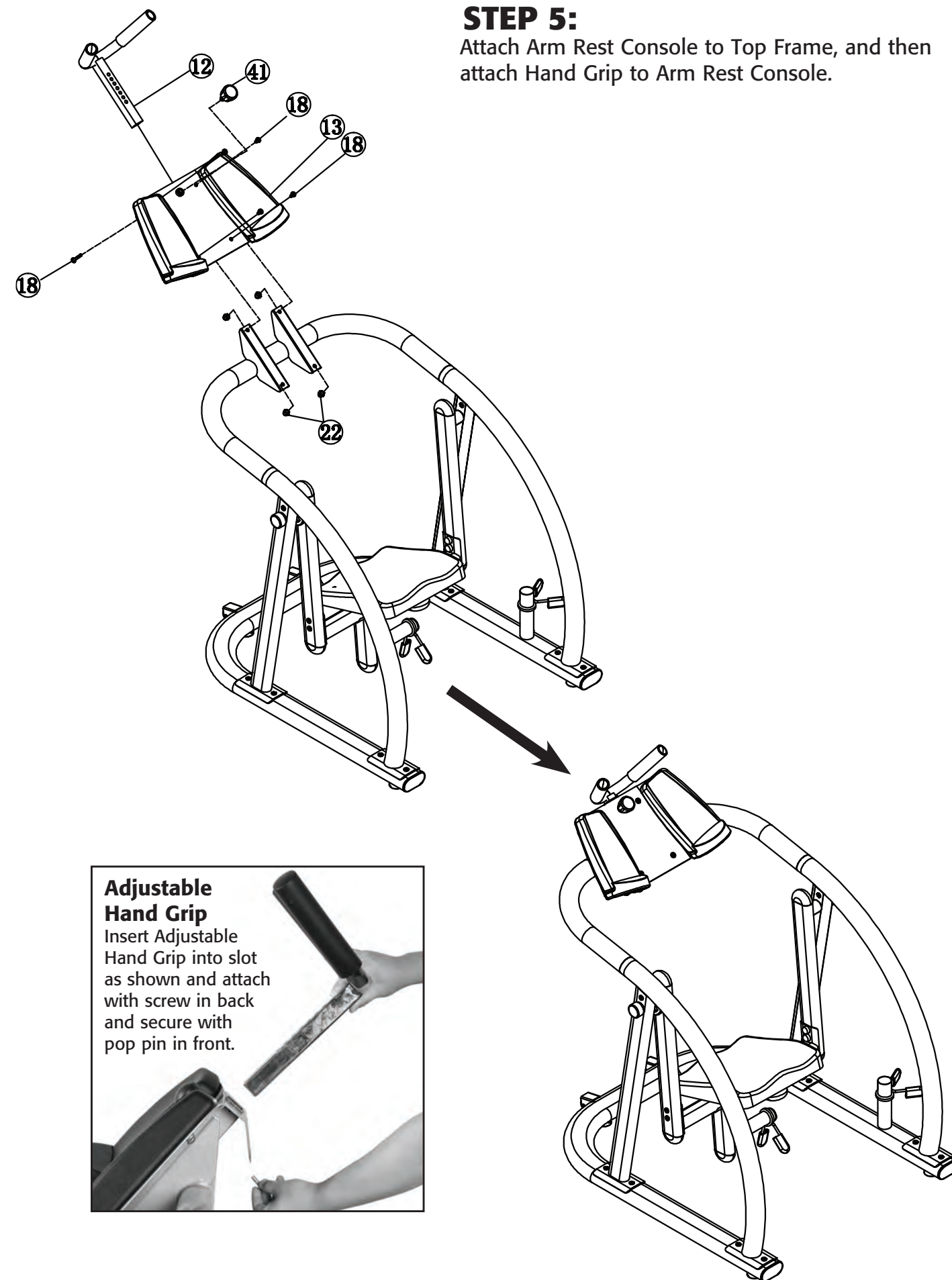

Adjustable Hand Grip

Insert Adjustable Hand Grip into slot as shown and attach with screw in back and secure with pop pin in front.



13



STEP 6:

Attach Plastic Covers.

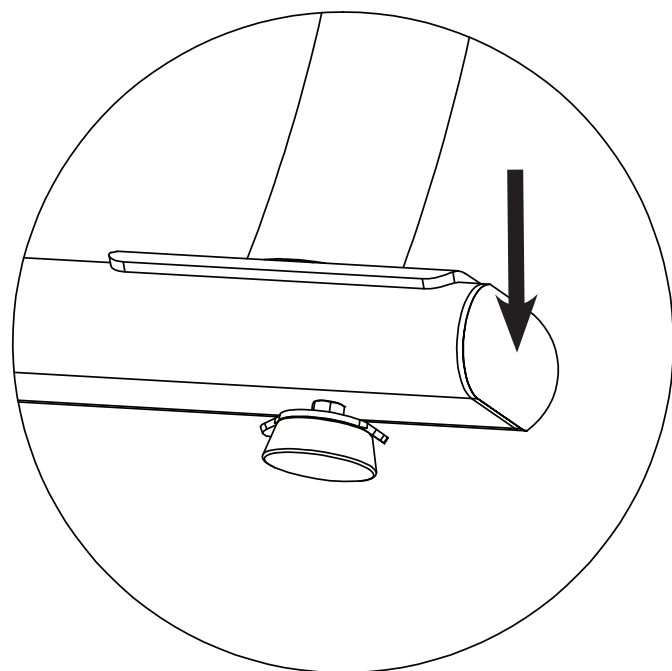

STEP 7:

Use hex key tool to firmly tighten all screws. **Be careful not to cross thread or overtighten screws.** The assembly process is now complete. Adjust LEVELERS located under front and rear feet as needed.

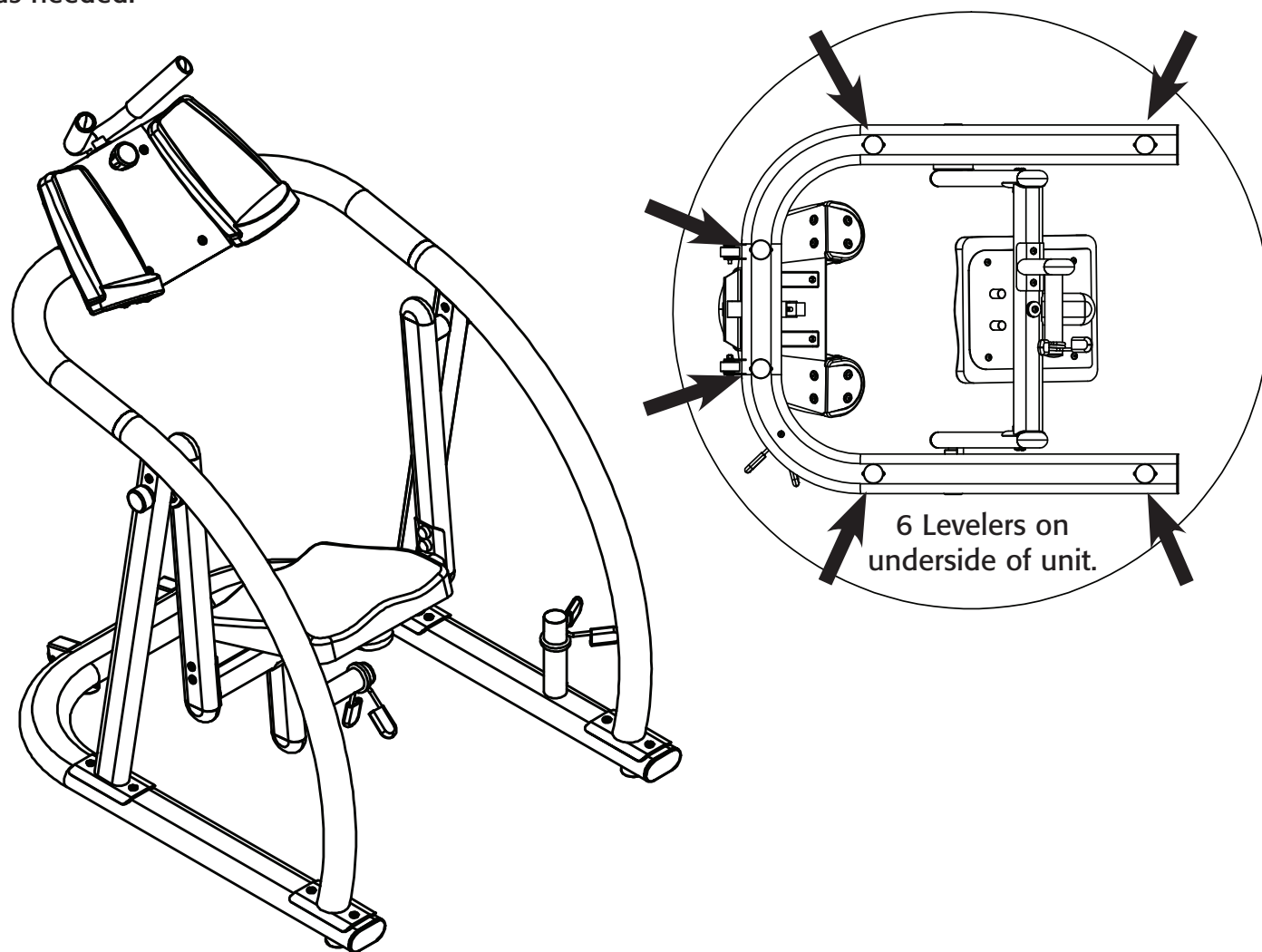

WARNING

SERIOUS INJURY COULD OCCUR IF THESE PRECAUTIONS ARE NOT OBSERVED.

- Read all warnings and obtain proper instruction on use of this machine prior to using.
- Obtain a medical exam prior to beginning an exercise program.
- Keep head, limbs, fingers and hair clear of all moving parts.
- Inspect machine prior to use. Do NOT use if it appears damaged or inoperable.
- Do NOT attempt to fix a broken or jammed machine. Notify floor staff.
- Use the machine only for intended use. Obtain instruction and DO NOT modify the machine.
- Children must not be allowed near this machine.
- Teenagers must be supervised in the use of this machine.
- DO NOT REMOVE THIS LABEL. REPLACE IF DAMAGED.

Manufacturer's Limited Warranty – AB COASTER® CTL

The manufacturer warrants that your Ab Coaster® is free of defects in materials and workmanship and will, at its option, repair or replace any defective Ab Coaster® that is returned to it. Except as described in the following sentence, all parts and components of the Ab Coaster are warranted for three (3) years from the original date of purchase. All pads are warranted for ninety (90) days from the date of original purchase.

This warranty is valid only in accordance with the conditions set forth below:

1. Normal wear and tear are not covered by this warranty.
2. The warranty extends only to the original purchaser and is not transferable. In addition, proof of purchase must be demonstrated.
3. This warranty is void if the product has been subject to accident, misuse, abuse, improper maintenance or repair, or unauthorized modification.
4. This limited warranty is the only written or express warranty given by the manufacturer. Any implied warranty of merchantability or fitness for a particular purpose on this product is limited in duration to the duration of this warranty.
5. Repair or replacement of the product (or, if repair or replacement is not feasible, a refund of the purchase price) is the exclusive remedy under this warranty. The manufacturer shall not be liable for any incidental or consequential damages for breach of this warranty or any implied warranty on this product.

MANUFACTURER MAKES NO WARRANTY OTHER THAN THE WARRANTY SET FORTH HEREIN. SUCH WARRANTY IS IN LIEU OF ALL OTHER WARRANTIES, EXPRESS OR IMPLIED, INCLUDING BUT NOT LIMITED TO ANY IMPLIED WARRANTY OF MERCHANTABILITY OR FITNESS FOR A PARTICULAR PURPOSE.