



DESIGNED TO INSPIRE A LIFE IN MOTION.

Every aspect of our fitness equipment is made to mirror human movement — fluid, natural, and familiar. Intuitive engineering and thoughtful design offer an invigorating workout that helps users keep moving. Arising from our heritage of providing quality fitness solutions that work, Precor fitness equipment keeps your users satisfied no matter what their goal. Precor inspires a life in motion.

Easy to use. Precor products are designed to be easy to use with adjustable weight increments and multiple pulley positions to help users target core muscle groups and reach their fitness goals.

Designed for Commercial Facilities. Precor has designed a Functional Training System to offer a variety of ergonomic strength exercises for users of all sizes. A compact footprint and low height make it a perfect fit for fitness rooms in hotels, apartment complexes, office buildings and more.

Committed to excellence. For 25 years Precor has been a leader in the fitness industry, delivering breakthrough innovations and premium quality products for leading clubs and better fitness facilities.

FTS GLIDE

FUNCTIONAL TRAINER

COMMERCIAL/

FTSGLIDE

COMMERCIAL FUNCTIONAL TRAINER

PRECOR®

1/ Simplified for ease of use

An instructional placard with illustrations guides users through effective exercise positions. Fully-shrouded weight stacks protect moving parts.

2/ User-friendly pulley adjustments refine exercise

Pulleys can be adjusted with one hand for quick transitions from one exercise to the next. Choose from 33 pulley positions to offer workout variety and ensure personal comfort for each core exercise.

3/ Dual weight stacks offer workout variety

Rather than working on just one or two planes of the body, dual weight stacks allow users to engage more than one muscle and often more than one joint for true isolateral resistance training with user-defined motion paths.

4/ Designed for durability

Contemporary design features a durable high-gloss, titanium powder coat finish that looks great in any workout room.

5/ Compact footprint maximizes space

Standing just 85 inches tall with stable, space-efficient design, the FTS Glide makes the most of any dedicated fitness area.



PRODUCT SPECIFICATIONS

Weight including weight stacks	472 lbs (214.1 kg)
Weight stacks (per stack)	200 lbs (90.7 kg)
Height	85 in (215.9 cm)
Width	53.1 in (134.9 cm)
Depth	48.3 in (122.7 cm)
Required area to place machine and perform most exercises	5 ft x 8 ft (1.52 x 3.01 m)

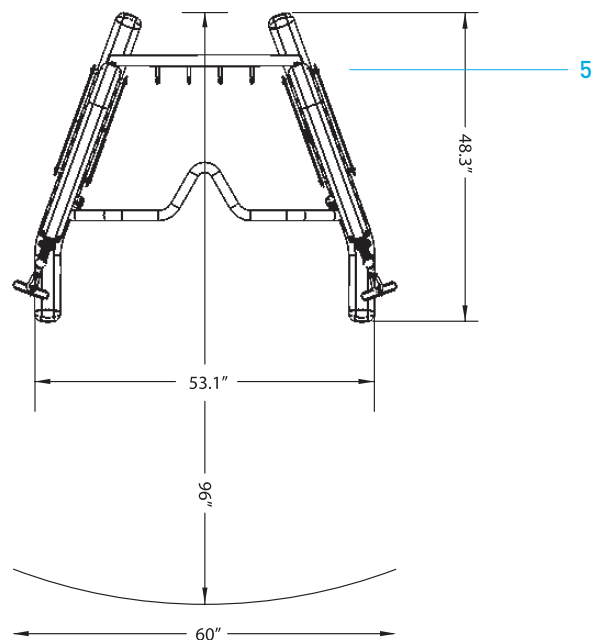

www.precor.com

BRFTS-101, 0408
©2008 Precor Incorporated