



SPIRIT FITNESS

A Heritage of Quality | The Spirit of Innovation



XT685 Treadmill OWNER'S MANUAL

Please carefully read this entire manual before operating your new treadmill

Product Registration	1
Important Safety Instructions	2
Important Electrical Instructions	3
Important Operation Instructions	4
XT685 Assembly Instructions	5
Transportation Instructions	11
Product Features	12
Operation of Your Console	14
Programmable Features	17
Using Heart Rate Transmitter	26
General Maintenance	28
Service Checklist - Diagnosis Guide	31
Manufacturer's Limited Warranty	33



Congratulations on your new treadmill and welcome to the Spirit Fitness family!

Thank you for your purchase of this quality group treadmill from Spirit Fitness. Your new treadmill was manufactured by one of the leading fitness manufacturers in the world and is backed by one of the most comprehensive warranties available. Through your dealer, Spirit Fitness will do all we can to make your ownership experience as pleasant as possible for many years to come. If not purchased direct from Spirit Fitness, the local dealership where you purchased this treadmill is your administrator for all Spirit Fitness warranty and service needs. Their responsibility is to provide you with the technical knowledge and service personnel to make your experience more informed and any difficulties easier to remedy.

Please take a moment at this time to record the name of the dealer, their telephone number, and the date of purchase below to make any future, needed contact easy. We appreciate your support and we will always remember that you are the reason that we are in business. Please complete and mail your registration card today and enjoy your new treadmill.

Yours in Health,
Spirit Fitness

Name of Dealer _____
Dealer Phone # _____
Purchase Date _____

Record Your Serial Number

Please record the serial number of this fitness product in the space provided below.

Serial Number _____



Register Your Purchase

The self-addressed product registration card must be completed in full and returned to Spirit Fitness. You can also go to <https://www.spiritfitness.com/residentialwarrantyregistration.html> to register online.

XT685_20130808

When using an electrical appliance, basic precautions should always be followed, including the following:

Read all instructions before using this appliance.

DANGER - To reduce the risk of electric shock:

1. Always unplug this appliance from the electrical outlet immediately after using and before cleaning.

WARNING - To reduce the risk of burns, fire electric shock, or injury to persons:

1. An appliance should never be left unattended when plugged in. Unplug from outlet when not in use, and before putting on or taking off parts.
2. Do not operate under blanket or pillow. Excessive heating can occur and cause fire, electric shock, or injury to persons.
3. Close supervision is necessary when this appliance is used by, on, or near children, invalids, or disabled persons.
4. Use this appliance only for its intended use as described in this manual. Do not use attachments not recommended by the manufacturer.
5. Never operate this appliance if it has a damaged cord or plug, if it is not working properly, if it has been dropped or damaged, or dropped into water. Return the appliance to a service center for examination and repair.
6. Do not carry this appliance by supply cord or use cord as a handle.
7. Keep the cord away from heated surfaces.
8. Never operate the appliance with the air openings blocked. Keep the air openings free of lint, hair, and the like.
9. Never drop or insert any object into any opening.
10. Do not use outdoors.
11. Do not operate where aerosol (spray) products are being used or where oxygen is being administered.
12. Connect this appliance to a properly grounded outlet only. See Grounding Instructions.
13. The appliance is intended for household use.

SAVE THESE INSTRUCTIONS - THINK SAFETY!

WARNING!

NEVER use a ground fault circuit interrupt (GFCI) wall outlet with this treadmill. As with any appliance with a large motor, the GFCI will trip often. Route the power cord away from any moving part of the treadmill including the elevation mechanism and transport wheels.

NEVER remove any cover without first disconnecting AC power. If voltage varies by ten percent (10%) or more, the performance of your treadmill may be affected. Such conditions are not covered under your warranty. If you suspect the voltage is low, contact your local power company or a licensed electrician for proper testing.

NEVER expose this treadmill to rain or moisture. This product is NOT designed for use outdoors, near a pool or spa, or in any other high humidity environment. The operating temperature specification is 40 to 120 degrees Fahrenheit, and humidity is 95% non-condensing (no water drops forming on surfaces).

Circuit Breakers: Some circuit breakers used in homes are not rated for high inrush currents that can occur when a treadmill is first turned on or even during use. If your treadmill is tripping the house circuit breaker (even though it is the proper current rating) but the circuit breaker on the treadmill itself does not trip, you will need to replace the home breaker with a high inrush type. This is not a warranty defect. This is a condition we as a manufacture have no ability to control. This part is available through most electrical supply stores. Examples: Grainger part # 1D237, or available online at www.squared.com part #QO120HM.

Grounding Instructions

This product must be grounded. If the treadmill should malfunction or breakdown, grounding provides a path of least resistance for electric current, reducing the risk of electric shock. This product is equipped with a cord having an equipment-grounding plug. The plug must be plugged into an appropriate outlet that is properly installed and grounded in accordance with all local codes and ordinances.

DANGER - Improper connection of the equipment-grounding conductor can result in a risk of electric shock. Check with a qualified electrician or serviceman if you are in doubt as to whether the product is properly grounded. Do not modify the plug provided with the product if it will not fit the outlet; have a proper outlet installed by a qualified electrician.

This product is for use on a nominal 110-volt circuit, and has a grounding plug that looks like the plug illustrated below. A temporary adapter that looks like the adapter illustrated below may be used to connect this plug to a 2-pole receptacle as shown below if a properly grounded outlet is not available. The temporary adapter should be used only until a properly grounded outlet, (shown below) can be installed by a qualified electrician. The green colored rigid ear-lug, or the like, extending from the adapter; must be connected to a permanent ground such as a properly grounded outlet box cover. Whenever the adapter is used, it must be held in place by a metal screw.

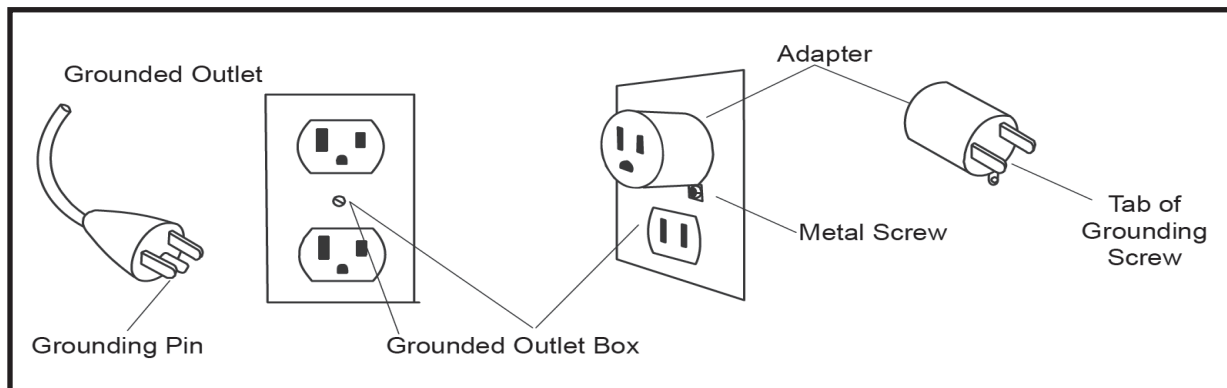

- **NEVER** operate this treadmill without reading and completely understanding the results of any operational change you request from the computer.
- Understand that changes in speed and incline do not occur immediately. Set your desired work level on the computer console and release the adjustment key. The computer will obey the command gradually.
- **NEVER** use your treadmill during an electrical storm. Surges may occur in your household power supply that could damage treadmill components. Unplug the treadmill during an electrical storm as a precaution.
- Use caution while participating in other activities while walking on your treadmill; such as watching television, reading, etc. These distractions may cause you to lose balance which may result in serious injury.
- Do not use excessive pressure on console control keys. They are precision set to function properly with little finger pressure.

Safety Tether Cord

- A safety tether cord is provided with this unit. It is a simple magnetic design that should be used at all times. It is for your safety should you fall or move too far back on the tread-belt. Pulling this safety tether cord will stop tread-belt movement. To Use:
 1. Place the magnet into position on the round metal portion of the console control head. Your treadmill will not start and operate without this. Removing the magnet also secures the treadmill from unauthorized use.
 2. Fasten the plastic clip onto your clothing securely to assure good holding power. Note: The magnet has strong enough power to minimize accidental, unexpected stopping. The clip should be attached securely to make certain it does not come off. Be familiar with its function and limitations. The treadmill will stop, depending on speed, with a one to two step coast anytime the magnet is pulled off the console. Use the Stop / Pause switch in normal operation.

Assembly Video

To assist you in assembling your new Spirit Fitness treadmill, we have posted an assembly video at the following link: <http://www.spiritfitness.com/customerservice/video/treadmillvideos.html>

Pre-Assembly

1. Cut the straps, then along the dotted line on the bottom of the box; lift the box over the unit and unpack.
2. Locate the hardware package. Remove the tools first. Remove the hardware for each step as needed to avoid confusion. The numbers in the instructions that are in parenthesis (**#**) are the item number from the assembly drawing for reference.

Assembly Tools

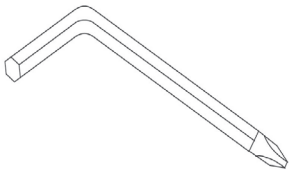

#106. Combination M5 Allen Wrench/
Phillips Head Screw Driver

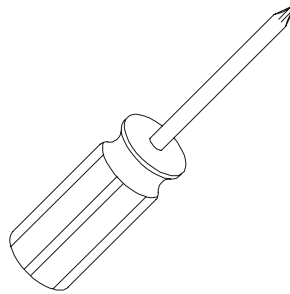

#109. Phillips Head Screw Driver

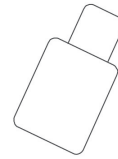

#18. Deck/Belt
Lubricant

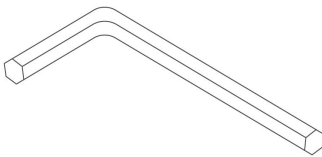

#107. M6 Allen
Wrench



#63. Safety Key

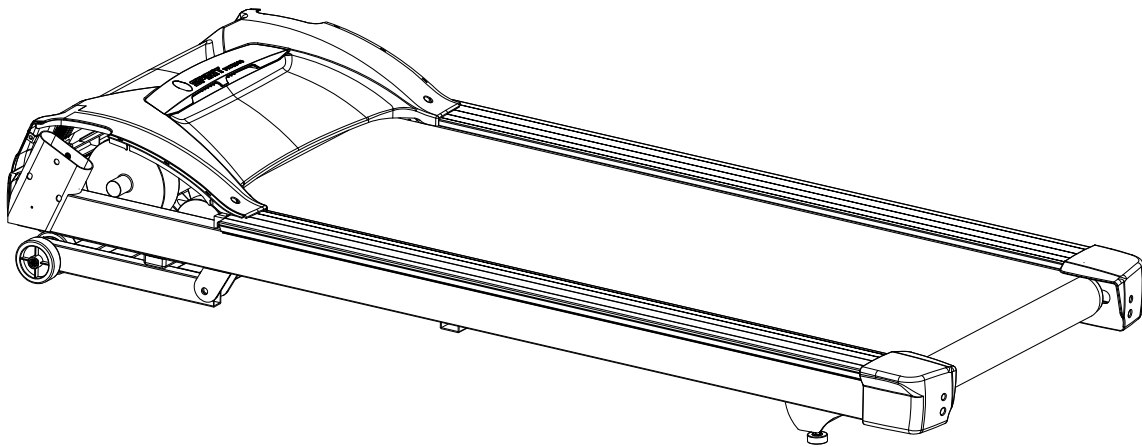

STEP 1: Console Mast Tubes

1. Slide the bottom console covers onto the console mast tubes (**52** onto **5** Left side & **53** onto **4** Right side). Make sure they are oriented as shown in the illustration.
2. Connect computer cables (**32** & **33**) on the right side.
3. Insert console mast tubes (**4** & **5**) into the frame. **Caution: Be careful not to pinch the cables you just connected. Doing so could affect the console function. Pull the end of the cable tight as you insert the right console mast tube.**
4. Insert three Button Head Socket Bolts (**102**) and one Button Head Socket Bolt (**103**) and Split Washer (**108**) on each side. Partially tighten these using the M6 Allen Wrench (**106**). Don't completely tighten these until the end of step 3.

HARDWARE

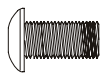

#102. 5/16" x 15mm
Button Head Socket
Bolt (6 pcs)

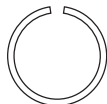

#108. 3/8" x 2T
Split Washer
(2 pcs)



#103. 3/8" x 2"
Button Head Socket Bolt
(2 pcs)

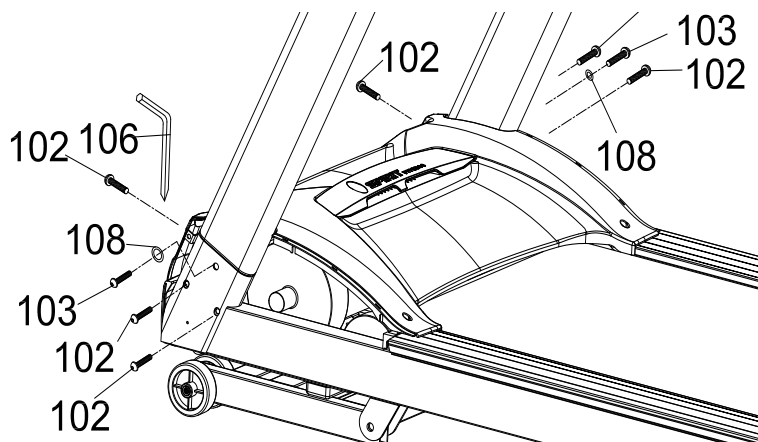
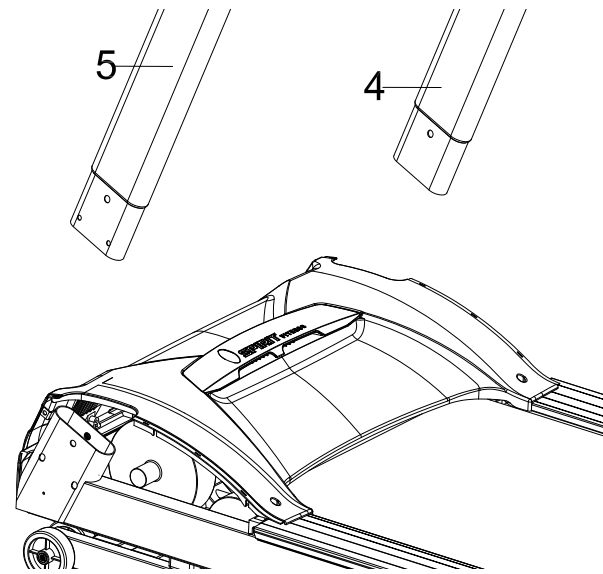
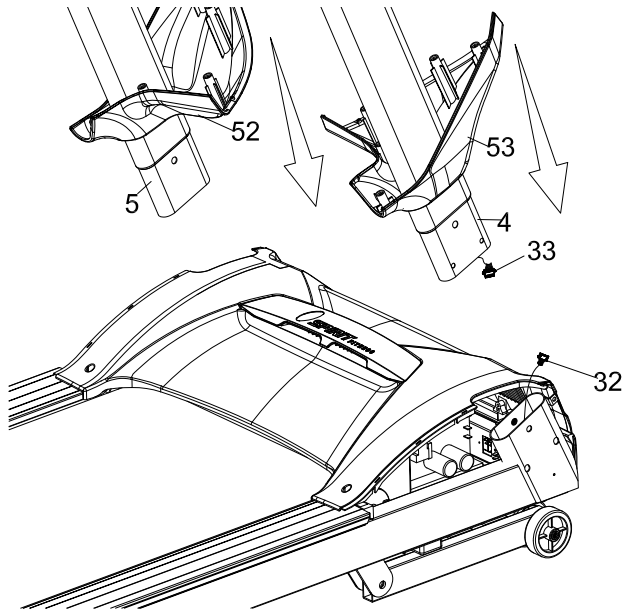

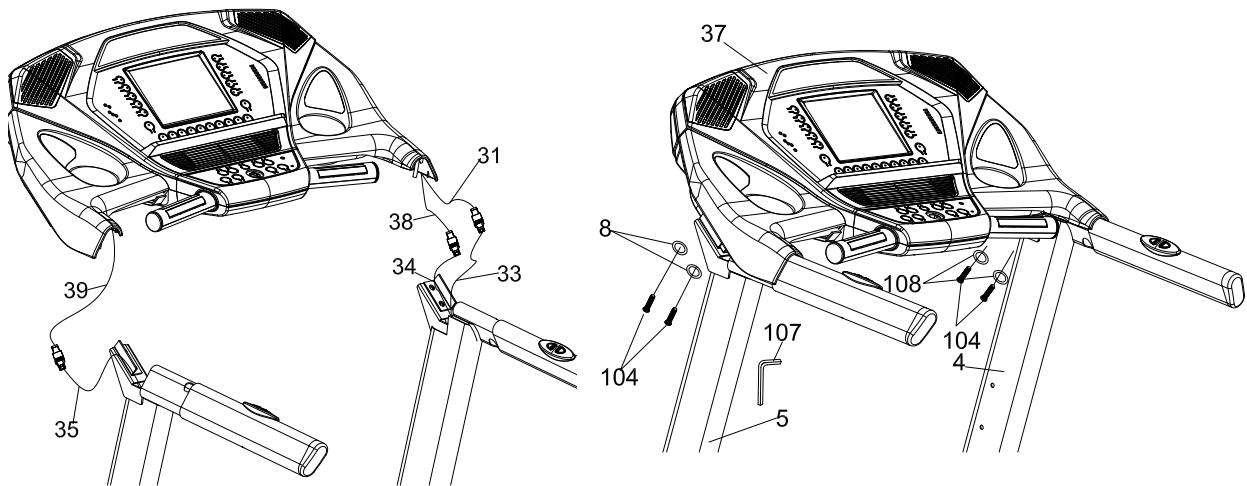

STEP 2: Console

1. Connect the following cables together: Incline cables (**35**) to (**39**), Speed cables (**34**) to (**38**), and Computer cables (**33**) to (**31**).
2. Place the console (**37**) onto the brackets at the top of the console mast tubes and attach with two Button Head Bolts (**104**) and two Split Washers (**108**) on each side. Caution: Be careful not to pinch any of the cables. Doing so may affect the console function. Firmly tighten with the Combination M5 Allen Wrench & Phillips Head Screw Driver (**107**).

HARDWARE

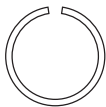

#108. 3/8" x 2.0T
Split Washer (4 pcs)



#104. 3/8" x 1-3/4"
Button Head Socket
Bolt (4 pcs)

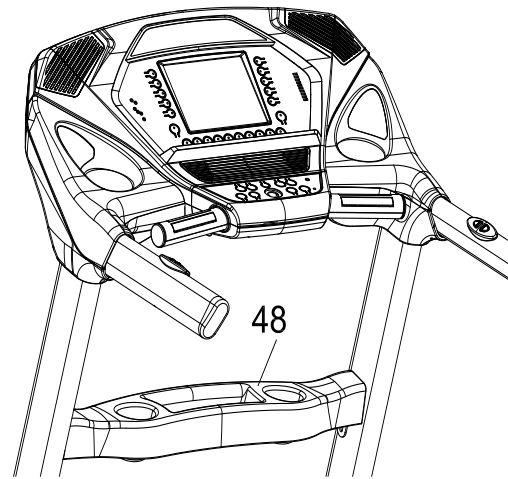
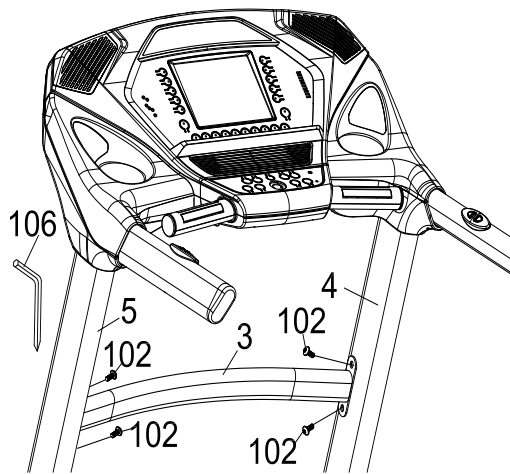
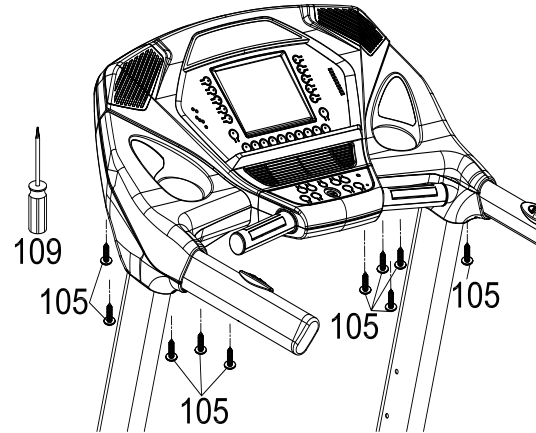
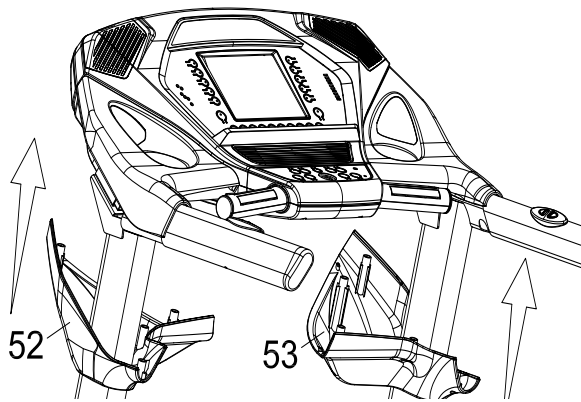

STEP 3: Console Covers & Cross Brace

1. Attach the bottom console covers (**52 & 53**) to the console with five Sheet Metal Screws (**105**) on each side. Tighten with the Phillips Head Screw Driver (**109**) or Combination M5 Allen Wrench & Phillips Head Screw Driver (**107**).
2. Attach the cross brace (**3**) to the console mast tubes (**4 & 5**) with two Button Head Socket Bolts (**102**) on each side. Tighten with the M6 Allen Wrench (**106**).
3. Firmly tighten the eight Button Head Socket Bolts inserted in Step 1 with the M6 Allen Wrench (**106**). Place the accessory holder tray (**48**) securely on top of the cross brace (**3**).

HARDWARE

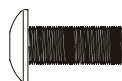

#102. 5/16" x 15mm
Button Head Socket
Bolt (4 pcs)



#105. 3.5 x 12mm
Sheet Metal Screw
(10 pcs)

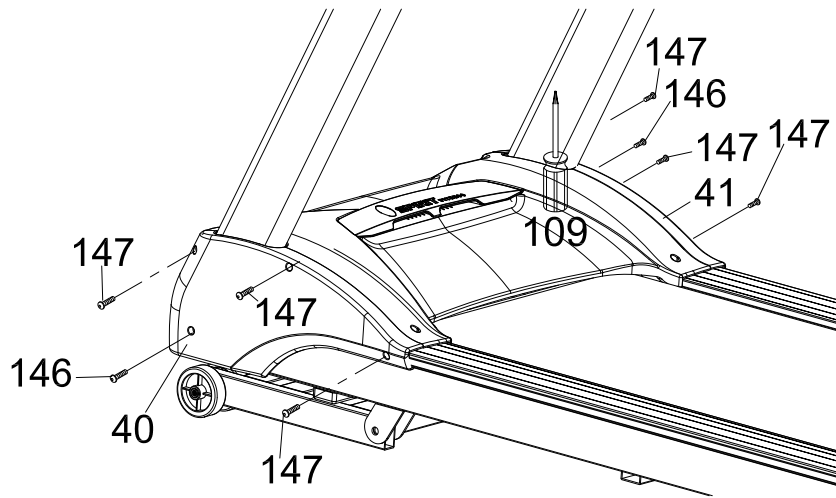
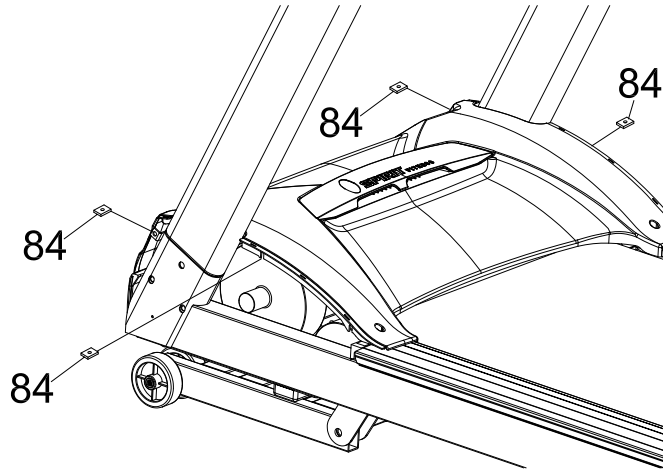

STEP 4: Side Covers

1. Place two M5 Speed Nut Clips (**84**) onto each side of the frame.
2. Attach the side covers (**40 & 41**) to the frame with one Self Tapping Screw (**146**) and three Sheet Metal Screws (**147**) on each side. Refer to the illustration for screw placement. Tighten with the Phillips Head Screw Driver (**109**).

HARDWARE

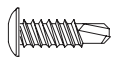

#146. 5 x 16mm
Self Tapping Screw
(2 pcs)



#84. Speed Nut
Clips (4 pcs)

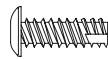

#147. 5 x 16mm
Sheet Metal Screw
(6 pcs)

Carefully lift the treadmill at the rear roller area, grasping the two end caps, and roll the treadmill away.

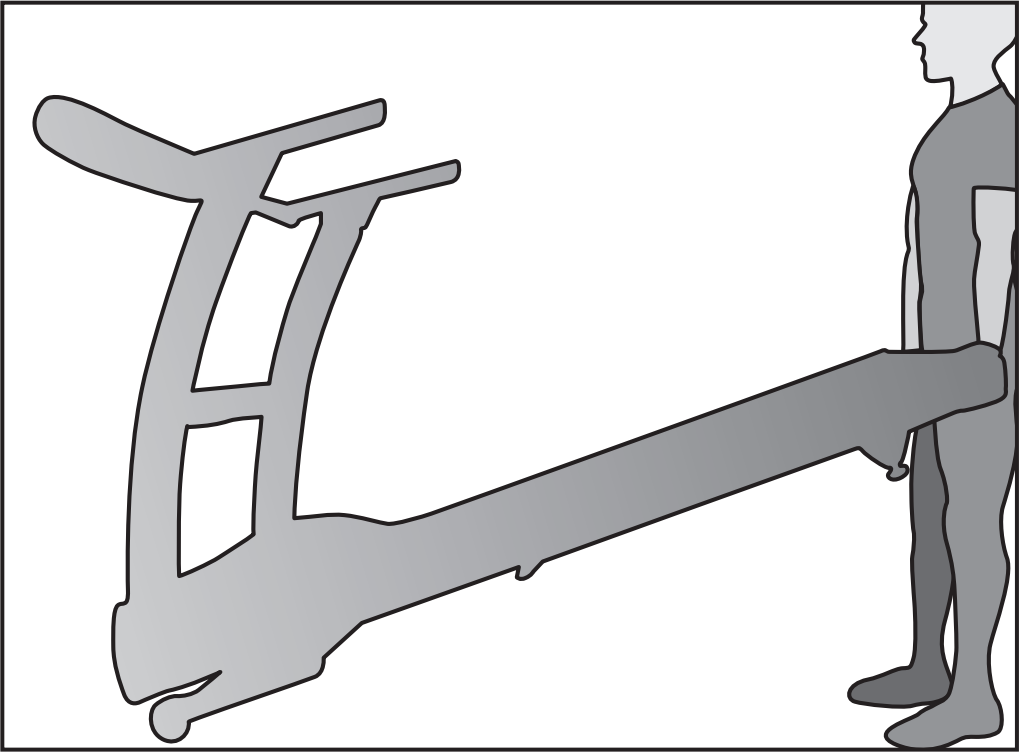

Handrail Adjustments

The **XT685** treadmill allows you to make speed and incline changes on the side handrails. You can also choose to turn these off if you frequently hold on to these rails. This is achieved by pressing the disable button on the right side of the lower portion of the console.

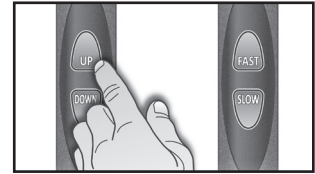

Quick Speed & Incline Buttons

You are able to set your speed and incline settings quickly by using the quick keys on the console. Just press either Speed or Incline, then select 2 digits, then press Enter and the treadmill will automatically adjust to that value. This saves time because you don't have to press and hold or hold a button down until reaching the desired value. The maximum value you may input for speed is 9.9 mph or kmph and incline level 9.5. Speed values can be entered in .1 mph increments and Incline in .5 level increments.



Examples:

Press the Quick Incline button, then 1, 0 = Incline Level 1.0

Press the Quick Incline button, then 3, 5 = Incline Level 3.5

Press the Quick Speed button, then 8, 0 = 8.0 mph or kmph

Press the Quick Speed button, then 0, 8 = 0.8 mph or kmph

Console

MUSCLE ACTIVATION FIGURE

There is an anatomical figure located at the top of the console. This figure will light all areas that are activated when using the treadmill. These will light up during any of the programs. You can control which muscles are activated by changing the incline and swinging your arms. The pre-set programs will determine which lower body muscles will be activated by automatically adjusting the incline. Generally the following guidelines hold true:

- The upper body LED's will light any time your hands aren't in contact with the pulse grip sensors
- The lower body lights will activate in three degrees of engagement: Green represents minimal muscle involvement, Amber represents medium involvement, and Red represents full or heavy activation.
 - 0-4.5% Elevation: even muscle distribution, all four muscle groups will be Amber
 - 5-15% Elevation: Quads are Amber and Glutes, Hamstrings, and Calves are Red



MESSAGE CENTER

The console will display Pace, Calories burned, Time (elapsed or countdown), Distance travelled, Pulse, Speed, Incline, Program Name, number of Laps completed, and Segment Time. There is also a Speed & Incline profile graph that lets you see how hard you have worked and how challenging the upcoming segments will be.

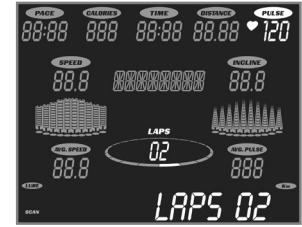

HEART RATE % PROFILE

The console LCD screen will display your current heart rate anytime a pulse is detected. The Bar Graph, located to the right of the LCD screen, will show your current heart rate % in relation to your projected maximum heart rate, which is determined by your age that you entered during the programming phase of any of the 10 programs. The significance of the bar graph colors are as follows:

- 50-60% of maximum is Amber
- 65-80% of maximum is Amber and Green
- 85-90% or more is Amber, Green, and Red

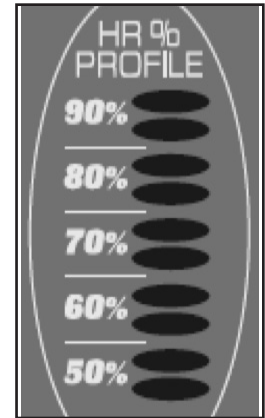

XT685 Console

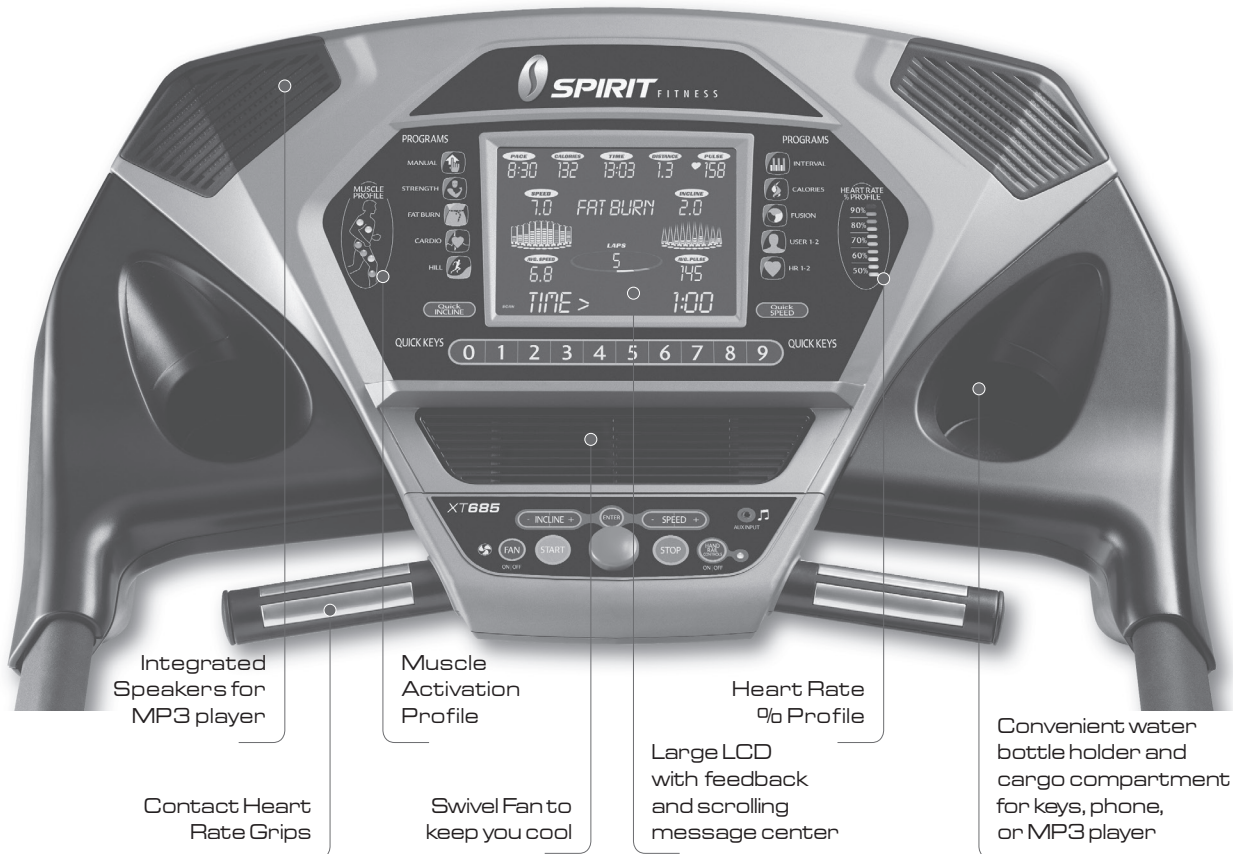

Getting Started

Power the treadmill on by plugging it into an appropriate wall outlet, then turn on the power switch located at the front of the treadmill below the motor cover. Ensure that the safety key is installed, as the treadmill will not power on without it.

When the power is turned on, all the lights on the display will light for a short time. Then the Time and Distance windows will display Odometer readings for a short time. The Time window will show how many hours the treadmill has been in use and the Distance window will show how many miles (or Kilometers if the treadmill is set to metric readings) the treadmill has gone. Then a message will scroll across the Message Center showing the current software version. The treadmill will then enter idle mode, which is the starting point for operation.

Quick Start/ Manual Operation

STEP 1: Press and release the **Start** key to wake display up (if not already on).

Note: Installing the tether key will also wake up the console.

STEP 2: Press and release the **Start** key to begin belt movement, at .5 mph, then adjust to the desired speed using the **Speed + / - or Fast/Slow** keys (console or hand rail). You may also use the quick speed key, then **0** through **9** to adjust the speed.

STEP 3: To slow the tread-belt press and hold the **Speed + / - or Fast/Slow** keys (console or hand rail) to the desired speed. You may also adjust to the desired speed by pressing **Quick Speed** and then **0** through **9**.

STEP 4: To adjust the Incline level, press and hold the **Incline + / - or Up / Down** keys; you may also adjust to the desired incline by pressing the **Quick Incline** key and then **0** through **9**.

STEP 5: To stop the tread-belt press and release the **Stop** key.

Pause/Stop/Preset

STEP 1: When the treadmill is running the pause feature may be utilized by pressing the red **Stop** key once. This will slowly decelerate the tread-belt to a stop. The incline will go to zero percent. The Time, Distance and Calorie readings will hold while the unit is in the pause mode. After 5 minutes the display will reset and return to the start up screen.

STEP 2: To resume your exercise, when in Pause mode, press the **Start** key. The speed and incline will return to their previous settings.

- Pause is executed when the **Stop** button is pressed once. If the **Stop** key is pressed a second time, the program will end and a workout summary will be displayed. If the Stop button is pressed a third time, the console will return to the idle mode (start up) screen. If the **Stop** button is held down for more than 3 seconds the console will reset.

Incline

- Incline may be adjusted anytime after belt movement.
- Press and hold the **Incline + / - or Up/Down** keys (console or hand rail) to achieve desired level of effort. You may also choose a more rapid increase / decrease by selecting the **Quick Incline** key, then **0** through **9**.
- The display will indicate incline percent in increments of .5 as adjustments are made.
- The incline will return to zero unless the main power switch or safety key are turned off while incline is at a higher setting.

Dot Matrix Center Display

Twenty columns of boxes (10 high) indicate each segment of a workout. The boxes only show an approximate level (speed/incline) of effort. They do not necessarily indicate a specific value - only an approximate percent to compare levels of intensity. In Manual Operation the Speed / Incline dot matrix window will build a profile "picture" as values are changed during a workout.

The speed and incline profiles will display half of the program at one time (10 columns). They will both scroll right to left. The Lap track will move in a counterclockwise direction.

1 / 4 Mile Track

The 1/4-mile track (one lap) will be displayed around the dot matrix window. The flashing segment indicates your progress. Once the 1/4-mile (Metric - 0.4k) is complete this feature will begin again. There is a lap counter in the message window for monitoring your distance.

Pulse Grip Feature

The Pulse (Heart Rate) console window will display your current heart rate in beats per minute during the workout. You must use both stainless steel sensors on the front cross bar or the heart rate transmitter chest strap to display your pulse. Pulse value displays anytime the upper display is receiving a Pulse signal. You may not use the Grip Pulse feature while in Heart Rate Programs.

Note: Refer to Important Safety Instructions (page 2) concerning Pulse Grip operation.

Calorie Display

Displays the cumulative calories burned at any given time during your workout.

Note: This is only a rough guide used for comparison of different exercise sessions, which cannot be used for medical purposes.

Speakers

The console has built-in Speakers. You may plug an Audio Source (CD player, MP3, Computer, etc.) into the Jack on the right side of console. There is no volume control on the console. The volume must be controlled on the Audio Source.

Handrail Buttons Disable Switch

To the right of the Stop button there is a Handrail control switch and an indicator light next to it. When the indicator light is lit, the handrail switches are disabled. This allows you to use the full length of the handrails without fear of activating the speed or elevation controls.

To Turn Treadmill Off

1. Display will automatically turn off (go to sleep) after 30 minutes (no key operations). The treadmill will draw very little current in sleep mode (about as much as your television when it is turned off).
2. Remove the Safety Key tether cord.
3. Turn off the main switch on the front of the treadmill, below the motor cover.

ATTENTION

Your new console comes configured in an in-store 'Display Mode' of operation, where the console will remain powered on unless the main power switch is turned off. To exit the display mode, for normal operation, press and hold the **Stop**, **Enter** and **Handrail Control Key** for 5 seconds; the display will show: "Display mode - On". Use any of the **Program**, **Incline** or **Speed +** keys to change the setting to Off then press **Enter**.

The **XT685** offers nine factory preset-programs, two user defined programs and one Manual program. Each preset program has a maximum speed level that is displayed when a desired workout is chosen. The maximum speed that the particular program will achieve will be displayed in the Speed window. Also included are two user programs (**User 1** and **User 2**) for custom workouts.

To Select and Start A Preset Program

STEP 1: Press the desired program (**Hill, Fat Burn, Cardio, Strength,** or Interval) key. Press **Enter** to select the program. The display will prompt you through the programming or you can just press **Start** to begin the program with default values.

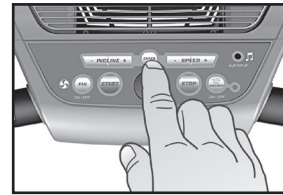

STEP 2: If **Enter** was pressed, the Message Center will now be blinking a value, indicating your Age (default is 35). Entering your correct age affects the heart rate Bar Graph Display and the Heart Rate programs. Use the **+ / -** keys to adjust, then press **Enter**. Your age determines your recommended maximum heart rate. Since the Bar Graph Display and the Heart Rate features are based on a percentage of your maximum heart rate, it is important to enter the correct age for these features to work properly.

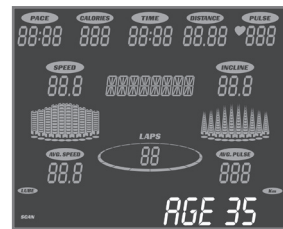

STEP 3: The Message Center will now be blinking a value, indicating your Body Weight (default is 150 lbs.). Entering the correct body weight will affect the calorie count. Use the **+ / -** keys to adjust, then press **Enter**. A note about the Calorie display: No exercise machine can give you an exact calorie count because there are too many factors which determine exact calorie burn for a particular person. Even if someone is the exact same body weight, age and height, their calorie burn may be very different than yours. The Calorie display is to be used as a reference only to monitor improvement from workout to workout.

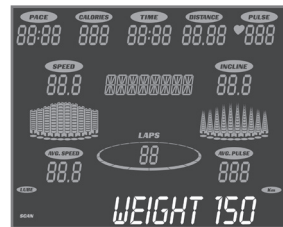

STEP 4: The Message Center will be blinking a value, indicating Time (the default value is 30 minutes). You may use any of the **+ / -** keys to adjust the time. After adjusting, or to accept the default, press **Enter**. (Note: You may press **Start** at any time during the programming to start the program).

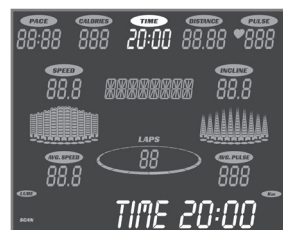

STEP 5: The Message Center will now be blinking the preset top speed of the selected program (3 mph or 5 kph). Use the Speed **+ / -** keys to adjust, then press **Enter**. Each program has various speed changes throughout; this allows you to limit the highest speed the program can reach.

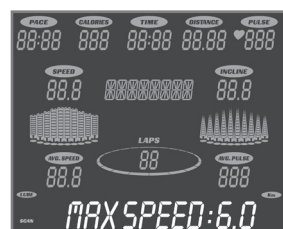

STEP 6: The Message Center will be blinking the preset top incline of the selected program (6.0%). Use the Incline **+ / -** keys to adjust, then press **Enter**.

You are now done programming data and may press **Start** to begin your workout or **Enter** to go back one level to change data entered in the programming phase.

User Programs

STEP 1: Press the **User 1-2** key once for **User 1** or twice for **User 2** then press **Enter**. Note that the dot matrix display portion will have a single row of segments at the bottom (Unless there is a previously stored program).

*If there is a program stored under the button that is pressed, it will be retrieved. If not, you have the option of programming in your first name. The message window will display and flash the letter "A". To change it, press the **Speed +** key, then "B" will be displayed; if the **Speed -** key is pressed, the letter "Z" will be displayed. After selecting the appropriate letter, press **Enter**. The letter "A" will again be displayed and blinking. Repeat the procedure until all letters of your first name are programmed (7 characters maximum). When your name is displayed, press **Stop** and it will be stored under either **User 1** or **User 2**.*

STEP 2: The Message Center will now be blinking an Age value. Adjust the age and press **Enter**.

STEP 3: The Message Center will now be blinking a bodyweight value. Enter your bodyweight and press **Enter**.

STEP 4: Note the clock/Message Center is flashing. Use the Adjust **+ / -** keys to adjust up from 30 minutes (if desired). Press the **Enter** key. This is a must to continue even if time is not adjusted.

STEP 5: The first column (segment) will now be blinking. Using the **+ / -** keys, adjust the speed level to your desired effort for the first segment then press **Enter**. The second column will now be blinking. Repeat the above process until all 20 segments have been programmed. The first column will be blinking again. This is for the incline programming. Repeat the above process to program all 20 segments for incline.

STEP 6: Press the **Start** button to begin the workout and also save the program to memory or press **Enter** to go back one step to reprogram.

Note: While in a User program, if you change the speed, all segment speeds from there on will also change.

Examples: If you increase your current speed 1 mph, the remaining segment speeds will increase by 1 mph. If you decrease your current speed .5 mph, the remaining segment speeds will decrease by .5 mph, etc.

Calorie Program

STEP 1: Press the **Calorie** key. Press **Enter** to select the program. The display will prompt you through the programming.

STEP 2: If **Enter** was pressed, the Message Center will now be blinking a value, indicating your Age (default is 35). Entering your correct age affects the heart rate Bar Graph Display and the Heart Rate programs. Use the **+ / -** keys to adjust, then press **Enter**. Your age determines your recommended maximum heart rate. Since the Bar Graph Display and the Heart Rate features are based on a percentage of your maximum heart rate, it is important to enter the correct age for these features to work properly.

STEP 3: The Message Center will now be blinking a value, indicating your Body Weight (default is 150 lbs.). Entering the correct body weight will affect the calorie count. Use the **+ / -** keys to adjust, then press **Enter**.

A note about the Calorie display: No exercise machine can give you an exact calorie count because there are too many factors which determine exact calorie burn for a particular person. Even if someone is the exact same body weight, age and height, their calorie burn may be very different than yours. The Calorie display is to be used as a reference only to monitor improvement from workout to workout.

STEP 4: The Message Center displays "Use **+ / -** keys to adjust Calorie burn" (default is 300) After adjusting, press **Enter**.

STEP 5: The Message Center will now be blinking the preset top speed of the selected program (3 mph or 5 kph). Use the **+ / -** keys to adjust, then press **Enter**. Each program has various speed changes throughout; this allows you to limit the highest speed the program can reach.

STEP 6: The Message Center will be blinking the preset top incline of the selected program (1.0%). Use the **Incline + / -** keys to adjust, then press **Enter**.

STEP 7: The Message Center displays the Program Time (a value that that was determined by the data you entered in steps 2-6); Press **Start** to accept the calculated Time or **Enter** to return to steps 3-5 and change the data, which will recalculate the Program Time.

- When the **Start** key is pressed, the program begins with a 3:00 warm up (1:00 @ 1mph, 1:00 @ 2mph, and 1:00 @ 3mph) or you have the option of pressing the **Start** key again to bypass and begin the workout.
- When the program begins both the Calorie and Time windows will count down to 0. If the Time expires before calories burned reaches 0, the Time window will begin accumulated time, until Calories reach 0.
- After the program has ended, there will be a 3:00 cool down (1:00 @ 1mph, 1:00 @ 2mph, and 1:00 @ 3mph) or you have the option of pressing the **Stop** key to end the workout.

Fusion Program

STEP 1: Press the **Fusion** key. Press **Enter** to select the program. The display will prompt you through the programming.

STEP 2: If **Enter** was pressed, the Message Center will now be blinking a value, indicating your Age (default is 35). Entering your correct age affects the heart rate Bar Graph Display and the Heart Rate programs. Use the **+ / -** keys to adjust, then press **Enter**. Your age determines your recommended maximum heart rate. Since the Bar Graph Display and the Heart Rate features are based on a percentage of your maximum heart rate, it is important to enter the correct age for these features to work properly.

STEP 3: The Message Center will now be blinking a value, indicating your Body Weight (default is 150 lbs.). Entering the correct body weight will affect the calorie count. Use the **+ / -** keys to adjust, then press **Enter**.

A note about the Calorie display: No exercise machine can give you an exact calorie count because there are too many factors which determine exact calorie burn for a particular person. Even if someone is the exact same body weight, age and height, their calorie burn may be very different than yours. The Calorie display is to be used as a reference only to monitor improvement from workout to workout. The calorie count displayed in this program won't be accurate because the machine can't calculate calories expended while strength training

STEP 4: The Message Center will now be blinking the preset top speed of the selected program (3 mph or 5 kph). Use the **+ / -** keys to adjust, then press **Enter**. Each program has various speed changes throughout; this allows you to limit the highest speed the program can reach.

STEP 5: The Message Center will be blinking the preset top incline of the selected program (1.0%). Use the **Incline + / -** keys to adjust, then press **Enter**.

STEP 6: The Message Center will be blinking the number of intervals desired (default is 10; you may select 10, 20, or 30). Use the **+ / -** keys to adjust, then press **Enter**.

STEP 7: The Message Center will be blinking the desired Interval time (default is 1:00). The time you select will be the duration of both the cardio & strength intervals. Note: on average you will complete 15-20 repetitions of the strength exercise in a 0:30 interval. As a general rule, the longer the interval, the less weight (dumbbells) and speed (treadmill) required; use the **+ / -** keys to adjust, then press **Enter**.

STEP 8: The Message Center will be blinking the desired recovery time you desire after completing both the cardio & strength intervals. Use the **+ / -** keys to adjust, then press **Enter**

Program Example:

- The user selects 10 intervals (5 cardio and 5 strength) with the following interval durations – length of each cardio & strength interval is 0:30, recovery interval is 1:00
- Program begins with a 3:00 warm up (1:00 @ 1mph, 1:00 @ 2mph, and 1:00 @ 3mph)
- 1st cardio interval begins, lasting 0:30; console counts down to 0:00 and the Message Center displays "STRENGTH INTERVAL BEGIN DUMBBELL ROW"
- User steps off of the treadmill to perform the strength exercise. The console counts down to 0:00 and beeps 3x signaling the user to get back on the treadmill.
- Console displays "PRESS START TO BEGIN RECOVERY"; user walks @ 2mph for 1:00
- Console then displays 2nd cardio interval and the process proceeds until the user has performed 5 cardio, strength, and recovery intervals; the 5 strength exercises will be performed sequentially as listed in this manual.
- The last 2:00 are a Cool Down phase with the user walking on the treadmill @ 2 mph

If 20 intervals was selected, you would perform each strength exercise twice, before moving on to the next exercise.

If 30 intervals is selected, you will perform each exercise once, then repeat the sequence of all 5 exercises a 2nd & 3rd time.

CAUTION

Exercises that require dumbbell use - Select a pair of dumbbells that you will be able to safely and effectively maneuver over the strength interval time you have chosen.

DUMBBELL BENT OVER ROW

EMPHASIS: MID/UPPER BACK & FRONT OF ARMS

1. Grasp the dumbbells with an overhand grip and arms fully extended in front of thighs; feet are spaced shoulder width apart
2. Maintain a slightly arched lower back throughout the exercise (see side view)
3. Begin the exercise by drawing your elbows up and out until there is a 90° bend in your elbows
4. Slowly lower the dumbbells back to the start position
5. Repeat this sequence for the duration of the strength interval

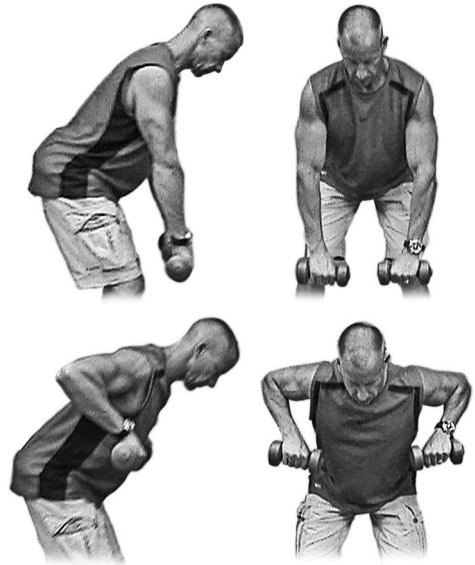

PUSH UP

EMPHASIS: CHEST, SHOULDERS, & BACK OF ARMS

There are two variations of this exercise. If you aren't able to perform the exercise as shown in this illustration, place your knees on the floor, a padded mat, or a pillow. Also, a wider hand position places more emphasis on the chest and shoulder muscles, while a narrower hand position places more emphasis on the Tricep muscles (back of the arm)

1. Place your hands on the floor or a set of dumbbells (Caution: be aware that the dumbbells may roll and result in injury, especially if the ends are round); draw your stomach muscles towards your spine to maintain a straight line between your ankles and shoulders
2. Begin with your elbows bent at 90°
3. Fully straighten your arms
4. Repeat this sequence for the duration of the strength interval

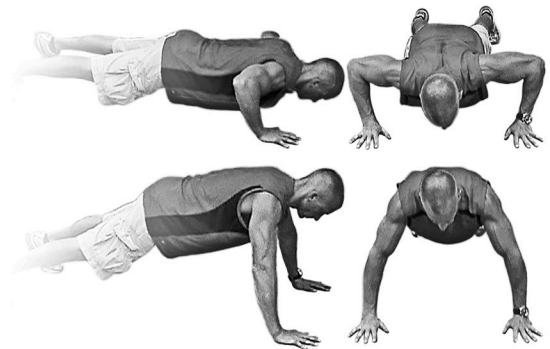

DUMBBELL SHOULDER PRESS

EMPHASIS: SHOULDERS

1. Hold the dumbbells at shoulder height with an overhand (palms facing forward) or neutral (palms facing one another) grip
2. Press the dumbbells straight overhead until your arms are fully extended
3. Slowly lower to the start position
4. Repeat this sequence for the duration of the strength interval

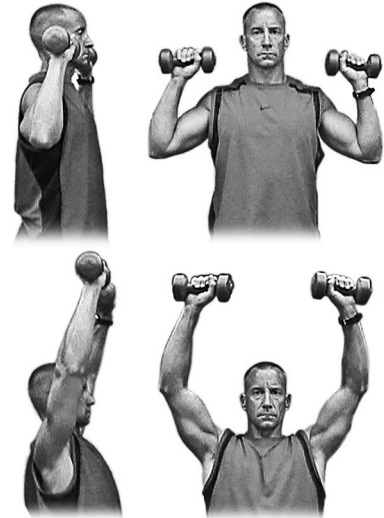

DUMBBELL TRICEP OVERHEAD EXTENSION

EMPHASIS: BACK OF ARMS

1. Hold the dumbbells at shoulder height behind your head with a neutral grip (palms facing one another); your elbows should be pointed straight ahead
2. Raise the dumbbells overhead until your arms are fully extended; your upper arms should remain stationary, pivoting at the elbows
3. Slowly lower to the start position
4. Repeat this sequence for the duration of the strength interval

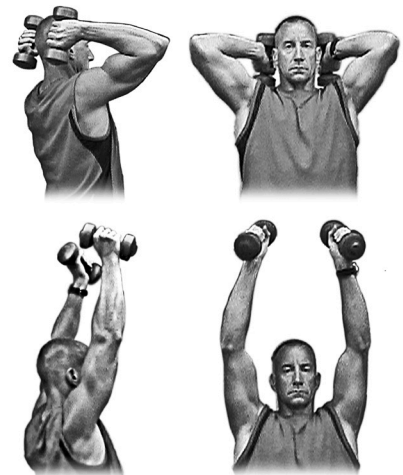

DUMBBELL BICEP CURL

EMPHASIS: FRONT OF ARMS

1. Hold the dumbbells with an underhand grip (palms facing forward) beside your thighs
2. Tuck your upper arms into your ribcage
3. Curl the dumbbells to shoulder height by pivoting at your elbows
4. Slowly lower to the start position
5. Repeat this sequence for the duration of the strength interval

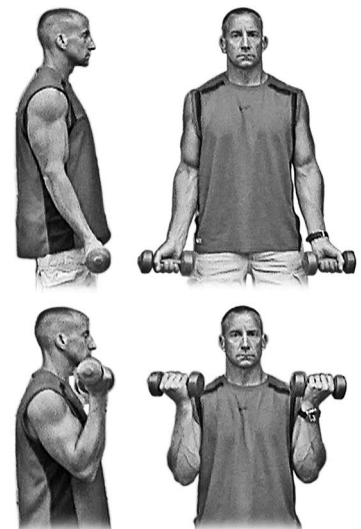

Preset Programs

The **XT685** has eight different programs that have been designed for a variety of workouts. Seven of these programs have factory preset Speed and Incline level profiles for achieving different goals.

HILL

Resistance: This program follows a triangle or pyramid type of gradual progression from approximately 10% of maximum effort (the level that you chose before starting this program) up to a maximum effort which lasts for 10% of the total workout time, then a gradual regression of resistance back to approximately 10% of maximum effort

Incline: The deck elevation is a more gradual and sustained progression. Maximum elevation is in the middle of the workout and lasts for 10% of the duration

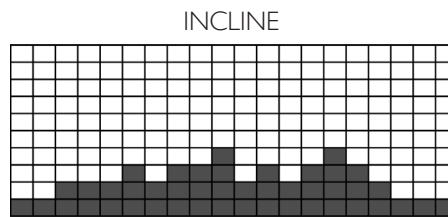
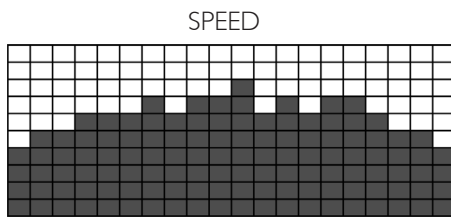

FAT BURN

Resistance: This program follows a quick progression up to the maximum speed level (default or user input level) that is sustained for 2/3 of the workout. This program will challenge your ability to sustain your energy output for an extended period of time.

Incline: The deck elevation is a quick and sustained progression up to the maximum value (default or user input) for 90% of the workout duration.

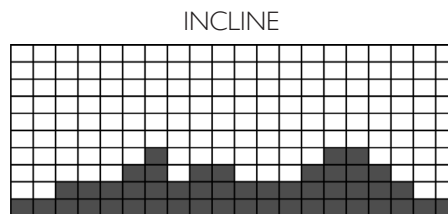
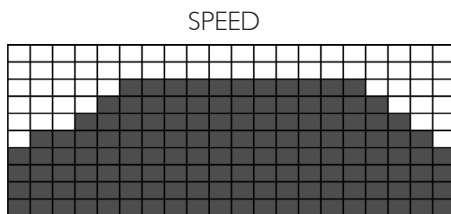

CARDIO

Resistance: This program presents a quick progression up to near maximum speed level (default or user input level). It has slight fluctuations up and down to allow your heart rate to elevate, and then recover repeatedly, before beginning a quick cool down. This will build up your heart muscle and increase blood flow and lung capacity.

Incline: The elevation in this program is moderate. There are several elevation spikes at different points of the workout. Segments 4, 9, and 14 are maximum elevation for this program.

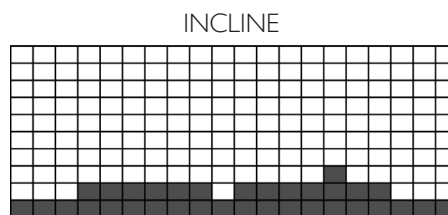
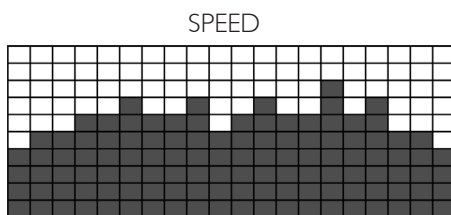

STRENGTH

Resistance: This program has a gradual progression of speed up to 100% of maximum effort that is sustained for 25% of workout duration. This will help build strength and muscular endurance in the lower body and gluts. A brief cool down follows.

Incline: There is a quick climb to a moderate, sustained elevation that lasts the majority of the workout length.

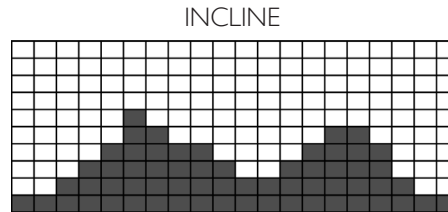
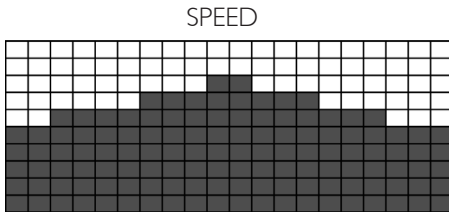

INTERVAL

Resistance: This program takes you through high levels of intensity followed by recovery periods of low intensity. This program utilizes and develops your "Fast Twitch" muscle fibers which are used when performing tasks that are intense and short in duration. These deplete your oxygen level and spike your heart rate, followed by periods of recovery and heart rate drop to replenish oxygen. Your cardiovascular system gets programmed to use oxygen more efficiently.

Incline: This program will spike similar to the speed profile, but in different segments (columns); this means that all of your lower extremity muscles will be equally challenged throughout this program. The incline alternates between 25 & 65 % of maximum elevation

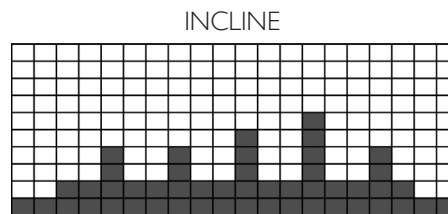
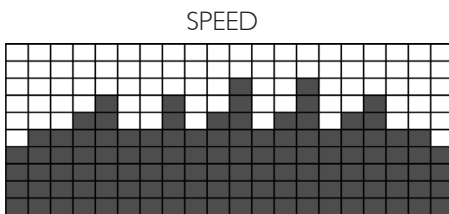

CALORIES

Resistance: This program follows a quick progression up to the maximum speed level (default or user input level) that is sustained for 2/3 of the workout. This program will challenge your ability to sustain your energy output for an extended period of time.

Incline: The treadmill elevation is a quick and sustained progression up to the maximum value (default or user input) for 90% of the workout duration.

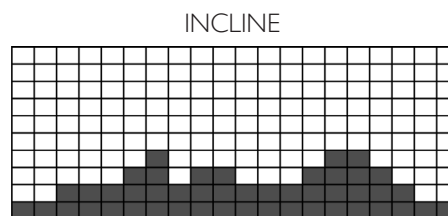

FUSION (Speed/Incline profile graphs are the same as the Interval Program above)

Resistance: This program takes you through high levels of cardio & strength intensity followed by recovery periods of low intensity. This program utilizes and develops your "Fast Twitch" muscle fibers which are used when performing tasks that are intense and short in duration. These deplete your oxygen level and spike your heart rate, followed by periods of recovery and heart rate drop to replenish oxygen. Your cardiovascular system gets programmed to use oxygen more efficiently.

Incline: This program will spike similar to the speed profile, but in different segments (columns); this means that all of your lower extremity muscles will be equally challenged throughout this program. The incline alternates between 25 & 65 % of maximum elevation

Heart Rate Programs

The old motto, "no pain, no gain", is a myth that has been overpowered by the benefits of exercising comfortably. A great deal of this success has been promoted by the use of heart rate monitors. With the proper use of a heart rate monitor, many people find that their usual choice of exercise intensity was either too high or too low and exercise is much more enjoyable by maintaining their heart rate in the desired benefit range.

To determine the benefit range in which you wish to train, you must first determine your Maximum Heart Rate. This can be accomplished by using the following formula: 220 minus your age. This will give you the Maximum Heart Rate (MHR) for someone of your age. To determine the effective heart rate range for specific goals you simply calculate a percentage of your MHR. Your Heart rate training zone is 50% to 90% of your maximum heart rate. 60% of your MHR is the zone that burns fat while 80% is for strengthening the cardio vascular system. This 60% to 80% is the zone to stay in for maximum benefit.

For someone who is 40 years old their target heart rate zone is calculated:

$$220 - 40 = 180 \text{ (maximum heart rate)}$$
$$180 \times .6 = 108 \text{ beats per minute}$$

(60% of maximum)

$$180 \times .8 = 144 \text{ beats per minute}$$

(80% of maximum)

So for a 40 year old the training zone would be 108 to 144 beats per minute.

If you enter your age during programming the console will perform this calculation automatically.

Entering your age is used for the Heart Rate programs. After calculating your MHR you can decide upon which goal you would like to pursue.

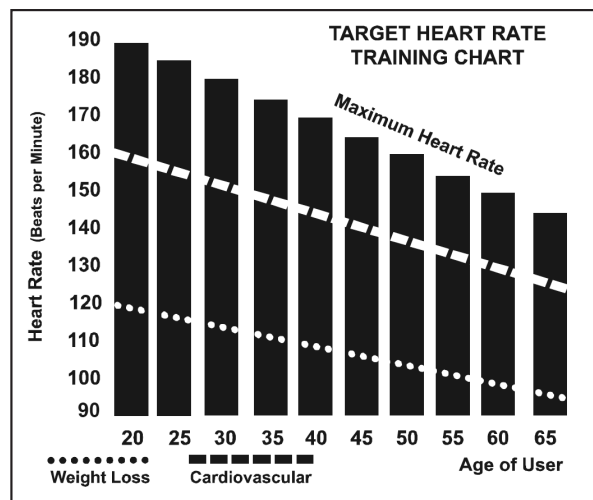

The two most popular reasons for, or goals, of exercise are cardiovascular fitness (training for the heart and lungs) and weight control. The black columns on the chart above represent the MHR for a person whose age is listed at the bottom of each column. The training heart rate, for either cardiovascular fitness or weight loss, is represented by two different lines that cut diagonally through the chart. A definition of the lines' goal is in the bottom left-hand corner of the chart. If your goal is cardiovascular fitness or if it is weight loss, it can be achieved by training at 80% or 60%, respectively, of your MHR on a schedule approved by your physician. Consult your physician before participating in any exercise program.

With all Spirit Fitness Heart Rate programs treadmills you may use the heart rate monitor feature without using the Heart Rate program. This function can be used during manual mode or during any of the eleven different programs. The Heart Rate program automatically controls elevation to keep you at your desired heart rate %.

Rate of Perceived Exertion

Heart rate is important but listening to your body also has a lot of advantages. There are more variables involved in how hard you should workout than just heart rate. Your stress level, physical health, emotional health, temperature, humidity, the time of day, the last time you ate and what you ate, all contribute to the intensity at which you should workout. If you listen to your body, it will tell you all of these things.

The rate of perceived exertion (RPE), also known as the Borg scale, was developed by Swedish physiologist G.A.V. Borg. This scale rates exercise intensity from 6 to 20 depending upon how you feel or the perception of your effort.

The scale is as follows:

Rating Perception of Effort

- 6 Minimal
- 7 Very, very light
- 8 Very, very light +
- 9 Very light
- 10 Very light +
- 11 Fairly light
- 12 Comfortable
- 13 Somewhat hard
- 14 Somewhat hard +
- 15 Hard
- 16 Hard +
- 17 Very hard
- 18 Very hard +
- 19 Very, very hard
- 20 Maximal

You can get an approximate heart rate level for each rating by simply adding a zero to each rating. For example a rating of 12 will result in an approximate heart rate of 120 beats per minute. Your RPE will vary depending upon the factors discussed earlier. That is the major benefit of this type of training. If your body is strong and rested, you will feel strong and your pace will feel easier. When your body is in this condition, you are able to train harder and the RPE will support this. If you are feeling tired and sluggish, it is because your body needs a break. In this condition, your pace will feel harder. Again, this will show up in your RPE and you will train at the proper level for that day.

Wearing The Chest Strap

1. Attach the transmitter to the elastic strap using the locking parts.
2. Adjust the strap as tightly as possible as long as the strap is not too tight to remain comfortable.
3. Position the transmitter with the logo centered in the middle of your torso facing away from your chest (some people must position the transmitter slightly left of center). Attach the final end of the elastic strap by inserting the round end and, using the locking parts, secure the transmitter and strap around your chest.
4. Position the transmitter directly below the pectoral muscles.
5. Sweat is the best conductor to measure very minute heart beat electrical signals. However, plain water can also be used to pre-wet the electrodes (2 ribbed oval areas on the reverse side of the belt and both sides of the transmitter). It's also recommended that you wear the transmitter strap a few minutes before your work out. Some users, because of body chemistry, have a more difficult time in achieving a strong, steady signal at the beginning. After "warming up", this problem lessens. As noted, wearing clothing over the transmitter/strap doesn't affect performance.
6. Your workout must be within range - distance between transmitter/receiver – to achieve a strong steady signal. The length of range may vary somewhat but generally stay close enough to the console to maintain good, strong, reliable readings. Wearing the transmitter directly on bare skin assures you of proper operation. If you wish, you may wear the transmitter over a shirt. To do so, wet the areas of the shirt that the electrodes will rest upon.

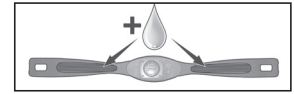

Note: The transmitter is automatically activated when it detects activity from the user's heart. Additionally, it automatically deactivates when it does not receive any activity. Although the transmitter is water resistant, moisture can have the effect of creating false signals, so you should take precautions to completely dry the transmitter after use to prolong battery life (estimated transmitter battery life is 2500 hours). The replacement battery is Panasonic CR2032.

Erratic Operation

Caution! Do not use this treadmill for Heart Rate programs unless a steady, solid Actual Heart Rate value is being displayed. High, wild, random numbers being displayed indicate a problem.

Areas to look for interference which may cause erratic heart rate:

1. Microwave ovens, TV's, small appliances, etc.
2. Fluorescent lights.
3. Some household security systems.
4. Perimeter fence for a pet.
5. Some people have problems with the transmitter picking up a signal from their skin. If you have problems try wearing the transmitter upside down. Normally the transmitter will be oriented so the Spirit Fitness logo is right side up.
6. The antenna that picks up your heart rate is very sensitive. If there is an outside noise source, turning the whole machine 90 degrees may de-tune the interference.
7. Another Individual wearing a transmitter within 3' of your machine's console.

If you continue to experience problems contact your dealer.

Heart Rate Program Operation

Note: You must wear the heart rate transmitter strap for these programs

Both programs operate the same, the only difference is that **HRI** is set to 60% and **HR2** is set to 80% of the maximum heart rate. They both are programmed the same way.

To start a HR program follow the instructions below or just select the **HRI** or **HR2** program, then the **Enter** button and follow the directions in the Message Center.

After selecting your heart rate target, the program will attempt to keep you at or within 3 - 5 heart beats per minute of this value. Follow the prompts in the Message Center to maintain your selected heart rate value.

1. Press the **HR 1-2** key once (60% of max heart rate default) or twice (80% of max heart rate default) key, then press the **Enter** key.
2. The Message Center will ask you to enter your Age. You may enter your age, using the **Speed + / -** keys, then press the **Enter** key to accept the new value and proceed on to the next screen.
3. You are now asked to enter your Weight. You may adjust the weight value using the **Speed + / -** keys, then press **Enter** to continue.
4. Next is Time. You may adjust the time using the **Speed + / -** keys and press **Enter** to continue.
5. Now you are asked to adjust the Heart Rate Target. This is the heart rate level you will strive to maintain during the program. Adjust the level using the **Speed + / -** keys, then press **Enter**. *Note: The heart rate that appears is based on the % you accepted in Step 1. If you change this number it will either increase or decrease the % from Step 1.*
6. Now you are finished editing the settings and can begin your workout by pressing the **Start** key. You can also go back and modify your settings by pressing the **Stop** key.
7. If you want to increase or decrease the workload at any time during the program press the **Speed + / -** key on the console or right handlebar. This will allow you to change your target heart rate at any time during the program.
8. During the **HR 1** or **HR 2** programs you will be able to scroll through the data in the Message Center by pressing the **Enter** key.
9. When the program ends you may press **Start** to begin the same program again, **Stop** to exit the program or you can save the program you just completed as a custom user program by pressing a **User** key and following the instructions in the Message Center.

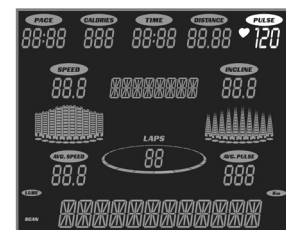

General Cleaning

Dirt, dust, and hair can block air inlets and accumulate on the running belt. Please vacuum underneath your treadmill on a monthly basis to prevent excess build-up of dirt that can get sucked up and get into the inner workings under the motor cover. Every other month, you should remove the motor cover and carefully vacuum out dirt and hair that may accumulate.

UNPLUG THE POWER CORD BEFORE THIS TASK.

(Use the chart at the beginning of the manual to record your maintenance)

Belt Adjustments

Tread-belt Tension Adjustment - Belt tension is not critical for most users. It is very important though for joggers and runners in order to provide a smooth, steady running surface.

Adjustment must be made from the rear roller with the 6mm Allen wrench provided in the parts package. The adjustment bolts are located at the end of the step rails as shown in the diagram below.

Tighten the rear roller only enough to prevent slippage at the front roller. Turn the tread-belt tension adjusting bolts 1/4 turn each and inspect for proper tension by walking on the belt and making sure it is not slipping or hesitating with each step. When an adjustment is made to the belt tension, you must be sure to turn the bolts on both sides evenly or the belt could start tracking to one side instead of running in the middle of the deck.

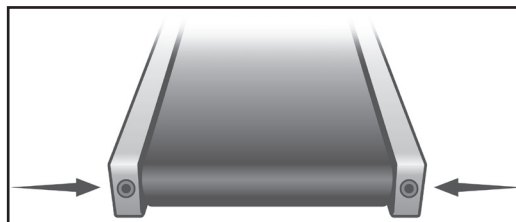

DO NOT OVERTIGHTEN – Over tightening will cause belt damage and premature bearing failure. If you tighten the belt a lot and it still slips, the problem could actually be the drive belt - located under the motor cover - that connects the motor to the front roller. If that belt is loose it feels similar to the walking belt being loose. Tightening the motor belt should be done by a trained service person.

Treadbelt Tracking Adjustment

The treadmill is designed so that the tread-belt remains reasonably centered while in use. It is normal for some belts to drift near one side while in use, depending on a user's gait and if they favor one leg. But if during use the belt continues to move toward one side, adjustments are necessary.

SETTING TREAD-BELT TRACKING

An 6mm Allen wrench is provided for this adjustment. Make tracking adjustments on the left side bolt. Set belt speed at 3 mph. Be aware that a small adjustment can make a dramatic difference which may not be apparent right away. If the belt is too close to the left side, then turn the bolt only a 1/4 turn to the right (clockwise) and wait a few minutes for the belt to adjust itself. Continue to make 1/4 turns until the belt stabilizes in the center of the running deck.

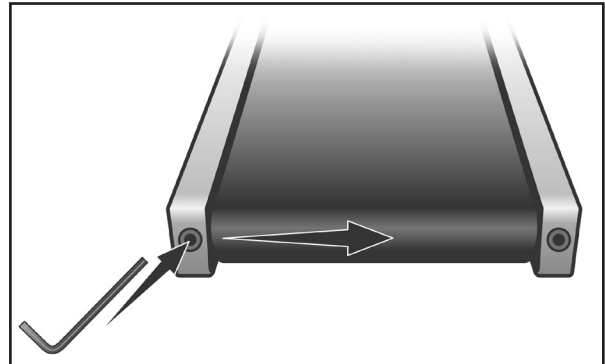

If the belt is too close to the right side, turn the bolt counter-clockwise. The belt may require periodic tracking adjustment depending on use and walking/running characteristics. Some users may affect tracking differently. Expect to make adjustments as required to center the tread-belt. Adjustments will become less of a maintenance concern as the belt is used. Proper belt tracking is an owner responsibility common with all treadmills.

ATTENTION

Damage to the running belt resulting from improper tracking / tension adjustments is not covered under the Spirit Fitness warranty.

Belt/Deck Lubrication Procedure

First, you want to clean between the belt and deck to remove any debris that may be trapped. Use a clean, non-fraying rag, t-shirt, or light towel. Halfway between the end of the treadmill and motor cover, shove the garment under the belt until you can grasp it on both sides of the belt. Drag the garment the length of the entire belt 1-2 times. Remove the garment.

Do not lubricate with anything other than Spirit Fitness approved lubricant. Your treadmill comes with one tube of "Lube" and extra tubes can be ordered directly from Spirit Fitness or your authorized Spirit Fitness dealer. You may also use a Lube-n-Walk kit that can be purchased through both aforementioned sellers.

Keeping the deck lubricated at the recommended intervals ensures the longest life possible for your treadmill. If the lubricant dries out, the friction between the belt and deck rises and places undue stress on the drive motor, drive belt and electronic motor control board, which could result in catastrophic failure of these expensive components. Failure to lubricate the deck at regular intervals may void the warranty.

The belt & deck come pre-lubricated and subsequent lubrication should be performed every 180 hours of use or if you notice that the deck is dry. It is recommended that you reach between the belt and deck to verify there is lubrication present, every other month. If you check and there isn't any lubrication present, follow the procedure below even though the "Lube" indicator isn't lit on the console. Otherwise, lubricate when the console's lubrication reminder lights after 180 hours of use. Use the following procedure to apply the silicone lubricant:

1. Turn the power switch off and unplug the power cord from the wall outlet
2. Measure 18" from the edge of the motor cover; kneel down and reach under the belt approximately 4- 6" from one edge. Squirt a line of lubricant about 1/8" wide x 15" long in an "S" pattern perpendicular to the motor cover.
3. Repeat the process on the opposite side.
4. Plug the electrical cord back into the outlet and turn the power switch on.
5. Walk on the belt at a moderate speed for five minutes to evenly distribute the silicone lube.
6. Note: If the "Lube" message appears on the console, perform the following procedure to reset the message:
 1. To enter the Engineering Mode Menu press and hold down the Start, Stop and Enter keys, then at the same time insert the safety key. Keep holding the keys down until the Message Center displays Engineering Mode Menu. Press the Enter button to access
 2. Press the Speed + button (or Speed – button to go backwards) until "Functions" appears; press Enter
 3. Press the Speed + button until "Reset Lube" message appears; press Enter
 4. Press Stop to exit Engineering mode and resume use of your treadmill

Problem	Solution/Cause
Display does not light	<ol style="list-style-type: none"> 1. Tether cord not in position. 2. Circuit breaker on front grill tripped. Push circuit breaker in until it locks. 3. Plug is disconnected. Make sure plug is firmly pushed into 115 VAC wall outlet. 4. Breaker panel circuit breaker may be tripped. 5. Treadmill defect. Contact your Spirit Fitness dealer.
Tread-belt does not stay centered Treadmill belt hesitates when walked/run on	The user may be walking while favoring or putting more weight on either the left or right foot. If this walking pattern is natural, track the belt slightly off-center to the side opposite from the belt movement. See General Maintenance section on Tread-belt Tension . Adjust as necessary.
Motor is not responsive after pressing start	<ol style="list-style-type: none"> 1. If the belt moves, but stops after a short time and the display shows "LS", run calibration. 2. If you press start and the belt never moves, then the display shows LS, contact service.
Treadmill will only achieve approximately 7 mph but shows higher speed on display	This indicates motor should be receiving power to operate. Low AC voltage to treadmill. Do not use an extension cord. If an extension cord is required it should be as short as possible and heavy duty 16 gauge minimum. Low voltage. Contact an electrician or your Spirit Fitness dealer. A minimum of 110 volt AC current is required.
Tread-belt stops quickly/suddenly when tether cord is pulled	High belt/deck friction. See General Maintenance section on cleaning the deck. If cleaning doesn't prevent this from reoccurring, check to see if there is significant wear of the deck. If so, the deck may need to be flipped if it is on its original side
Treadmill trips on board 15 amp circuit	High belt/deck friction. See General Maintenance . If cleaning doesn't prevent this from reoccurring, check the amp draw of the motor. If this is high and there are signs of significant wear of the deck, it may need to be flipped if it is on its original side
Computer shuts off when console is touched (on a cold day) while walking/running	Treadmill may not be grounded. Static electricity is "crashing" the computer. Refer to Grounding Instructions on page 3.
Circuit breaker trips, but not the treadmill circuit breaker	Need to replace the breaker with a "High In-rush current" type breaker (see page 3 for details)

Calibration Procedure

1. Remove the safety key
2. Press and hold down the **Start** and **Fast +** buttons and replace the safety key. Continue to hold the **Start** and **Fast** key until the window displays "Factory settings", then press the **Enter** key.
3. You will now be able to set the display to show Metric or English settings (Miles vs. Kilometers). To do this, press the **Up** or **Down** key to show which you want, then press **Enter**.
4. Make sure the wheel size diameter is 3.01 then press **Enter**
5. Adjust the minimum speed (if needed) to 0.5 and then press **Enter**
6. Adjust the maximum speed (if needed) to 12.0 and then press **Enter**
7. Adjust the maximum elevation (if needed) to 15 and then press **Enter**
8. Grade return – On (This allows the incline to return to zero when **Stop** is pressed. For sale in Europe, EU standards require this to be off)
9. Press **Start** to begin calibration. The process is automatic; the speed will start up without warning, so do not stand on the belt.

Adjusting The Speed Sensor

If the calibration does not pass you may need to check the speed sensor alignment.

1. Remove the motor cover hood by loosening the 8 screws that hold it in place. Set it aside.
2. The speed sensor is located on the left side of the frame, right next to the front roller pulley (the pulley will have a belt around it that also goes to the motor). The speed sensor is a small rectangular shaped black box with a wire connected to it.
3. You will see a magnet on the outside edge of the pulley; make sure the speed sensor is aligned with the center of the magnet when it passes by. There are two screws that hold the sensor in place that need to be loosened to adjust the sensor. Re-tighten the screws when finished.



Engineering Mode Menu

The console has built in maintenance/diagnostic software. The software will allow you to change the console settings from English to Metric and turn off the beeping of the speaker when a key is pressed for example. To enter the Engineering Mode Menu press and hold down the **Start**, **Stop** and **Enter** keys, then insert the safety key. Keep holding the keys down until the Message Center displays Engineering Mode Menu. Press the **Enter** button to access the menu below:

- a. KeyTest (Will allow you to test all the keys to make sure they are functioning)
- b. Security (Allows the keypad to be locked to prevent unauthorized use)
- c. Functions (Press **Enter** to access settings and **Up** arrow to scroll)
 - i. Display Mode (Turn off to have the console power down automatically after 30 minutes of inactivity; leave on to display all lights while the power is on)
 - ii. MotorTest (Press **Enter** to run the resistance motor up and down in a continuous loop. Display shows level setting and position sensor reading. Press **Stop** to end test.)
 - iii. Beep (Turns off the speaker so no beeping sound is heard)
 - iv. Units (Sets the display to readout in English or Metric display measurements)
 - v. ODO Reset (Resets the odometer)
 - vi. Pause Mode (Turn on allow 5 minutes of pause, turn off to have the console pause indefinitely)
- d. LCD Test (Tests all the display functions)

Treadmill Warranty - Effective March 1, 2012

Spirit Fitness, Inc. (Spirit Fitness) warrants all its treadmill parts for a period of time listed below from the date of retail sale, as determined by sale receipt, or in the absence of a sales receipt eighteen (18) months from the original factory shipping date. Spirit Fitness' responsibilities include providing new or remanufactured parts, at Spirit Fitness' option, and technical support to our independent dealers and servicing organizations. In the absence of a dealer or service organization, these warranties will be administered by Spirit Fitness directly to a consumer. The warranty period applies to the following components:

Warranty	Frame	Motor	Deck	Parts	Labor
Light Commercial (5 Hours use or less in a non-dues paying facility)	Lifetime	5 Years	3 Years	3 Years	1 Year
Residential	Lifetime	Lifetime	Lifetime	10 Years	1 Year

NORMAL RESPONSIBILITIES OF THE CONSUMER

This warranty applies only to products in ordinary household or Light Commercial use (see restrictions above), and the consumer/facility is responsible for the items listed below:

1. The warranty registration card must be completed and returned to the address listed on the card within 10 days of the original purchase to validate the manufacturer's limited warranty.
2. Proper use of the treadmill in accordance with the instructions provided in this manual
3. Proper installation in accordance with instructions provided with the treadmill and with all local electric codes.
4. Proper connection to a grounded power supply of sufficient voltage, replacement of blown fuses, repair of loose connections or defects in house or facility wiring.
5. Expenses for making the treadmill accessible for servicing, including any item that was not part of the treadmill at the time it was shipped from the factory.
6. Damages to the treadmill finish during shipping, installation or following installation.
7. Routine maintenance of this unit as specified in this manual.

EXCLUSIONS

This warranty does not cover the following:

1. CONSEQUENTIAL, COLLATERAL, OR INCIDENTAL DAMAGES SUCH AS PROPERTY DAMAGE AND INCIDENTAL EXPENSES RESULTING FROM ANY BREACH OF THIS WRITTEN OR ANY IMPLIED WARRANTY.
Note: Some states do not allow the exclusion or limitation of incidental or consequential damages, so this limitation or exclusion may not apply to you.
2. Service call reimbursement to the consumer; Service call reimbursement to the dealer that does not involve malfunction or defects in workmanship or material, for units that are beyond the warranty period, for units that are beyond the service call reimbursement period, for treadmill not requiring component replacement, or treadmill not in ordinary household or light commercial use.
3. Damages caused by services performed by persons other than authorized Spirit Fitness service companies; use of parts other than original Spirit Fitness parts; or external causes such as corrosion, discoloration of paint or plastic, alterations, modifications, abuse, misuse, accident, improper maintenance, inadequate power supply, or acts of God.
4. Products with original serial numbers that have been removed or altered.
5. Products that have been: sold, transferred, bartered, or given to a third party.
6. Products that do not have a warranty registration card on file at Spirit Fitness. Spirit Fitness reserves the right to request proof of purchase if no warranty record exists for the product.
7. THIS WARRANTY IS EXPRESSLY IN LIEU OF ALL OTHER WARRANTIES EXPRESSED OR IMPLIED, INCLUDING THE WARRANTIES OF MERCHANTABILITY AND/OR FITNESS FOR A PARTICULAR PURPOSE.
8. Product use in any environment other than a residential setting or non-dues paying facility with 5 hours use or less per day.
9. Warranties outside of the United States may vary. Please contact your local dealer for details.

SERVICE

Keep your bill of sale. Twelve (12) months from the date on the bill of sale or eighteen (18) months from the date of factory shipping as determined by the serial number establishes the labor warranty period should service be required. If service is performed, it is in your best interest to obtain and keep all receipts. This written warranty gives you specific legal rights. You may also have other rights that vary from state to state. Service under this warranty must be obtained by following these steps, in order:

1. Contact your selling authorized Spirit Fitness dealer. OR
2. Contact your local authorized Spirit Fitness service organization.
3. If there is a question as to where to obtain service, contact our service department at (870) 935-1107.
4. Spirit Fitness' obligation under this warranty is limited to repairing or replacing, at Spirit Fitness' option, the product through one of our authorized service centers. All repairs must be preauthorized by Spirit Fitness. If the product is shipped to a service center freight charges to and from the service center will be the customer's responsibility. For replacement parts shipped while the product is under warranty, the customer will be responsible for shipping and handling charges. For in-home service, the customer will be responsible for a trip charge. There will be an additional trip charge if the customer is located over 100 miles from the nearest service center.
5. The owner is responsible for adequate packaging upon return to Spirit Fitness. Spirit Fitness is not responsible for damages in shipping. Make all freight damage claims with the appropriate freight carrier: DO NOT SHIP ANY UNIT TO OUR FACTORY WITHOUT A RETURN AUTHORIZATION NUMBER. All units arriving without a return authorization number will be refused.
6. For any further information, or to contact our service department by mail, send your correspondence to:

Spirit Fitness, Inc.
P.O. Box 2037
Jonesboro, AR 72402-2037

Product features or specifications as described or illustrated are subject to change without notice. All warranties are made by Spirit Fitness, Inc. This warranty applies only in the 48 contiguous United States. NOTE: This does not apply to Alaska or Hawaii.

3000 Nestle Road Jonesboro, AR 72401 - Phone: 800-258-4555 - Fax: 870-935-7611

www.spiritfitness.com

© 2013 All Rights Reserved.
XT**685** Owner's Manual
Rev. 2